

Havnen

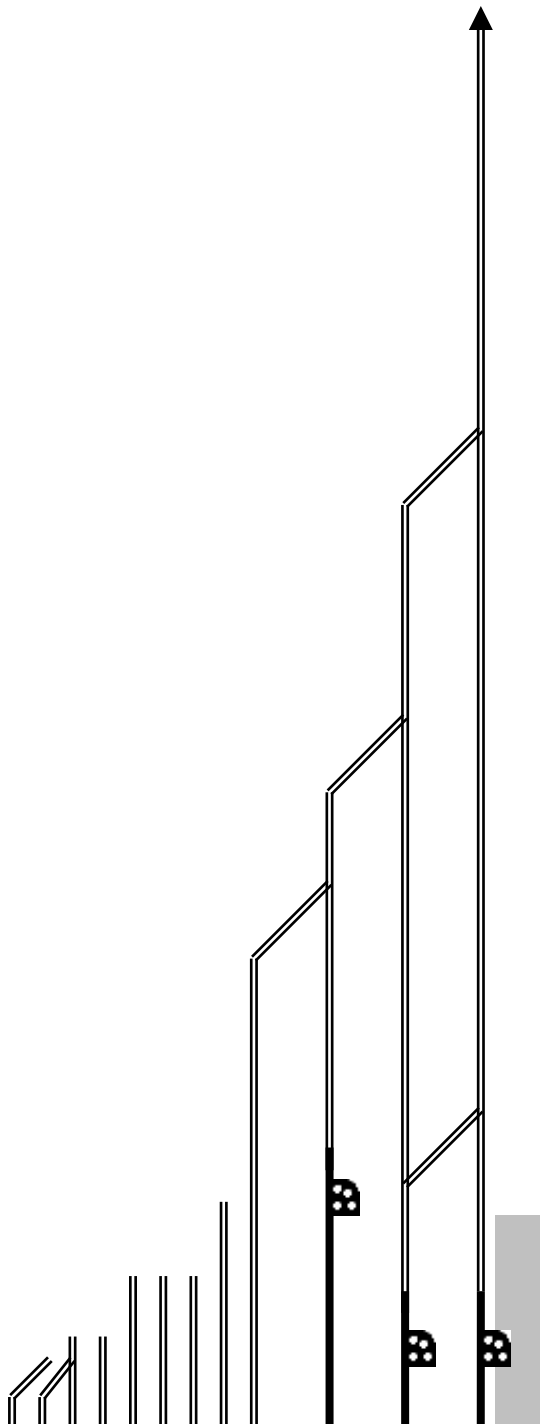

**Esbjerg (Es)**  
Overgangsstation

55,7

5 4 3 2 1 0

B

A

40>5  
40>4  
40>3  
40>2  
**40>1**  
40>0

56,3

40>5  
40>4  
40>3  
**40>2**  
40>1  
40>0

54,8



40

Forsyningen

F80

**Spangsbjerg (Esn)**

58,2

110

54,0

**Gjesing (Gje)**

60,1

Lykkegård

52,116 – 52,535

48,4

Linieblok / Vekselspor  
FC Es

Bramming str 29

© T Keis

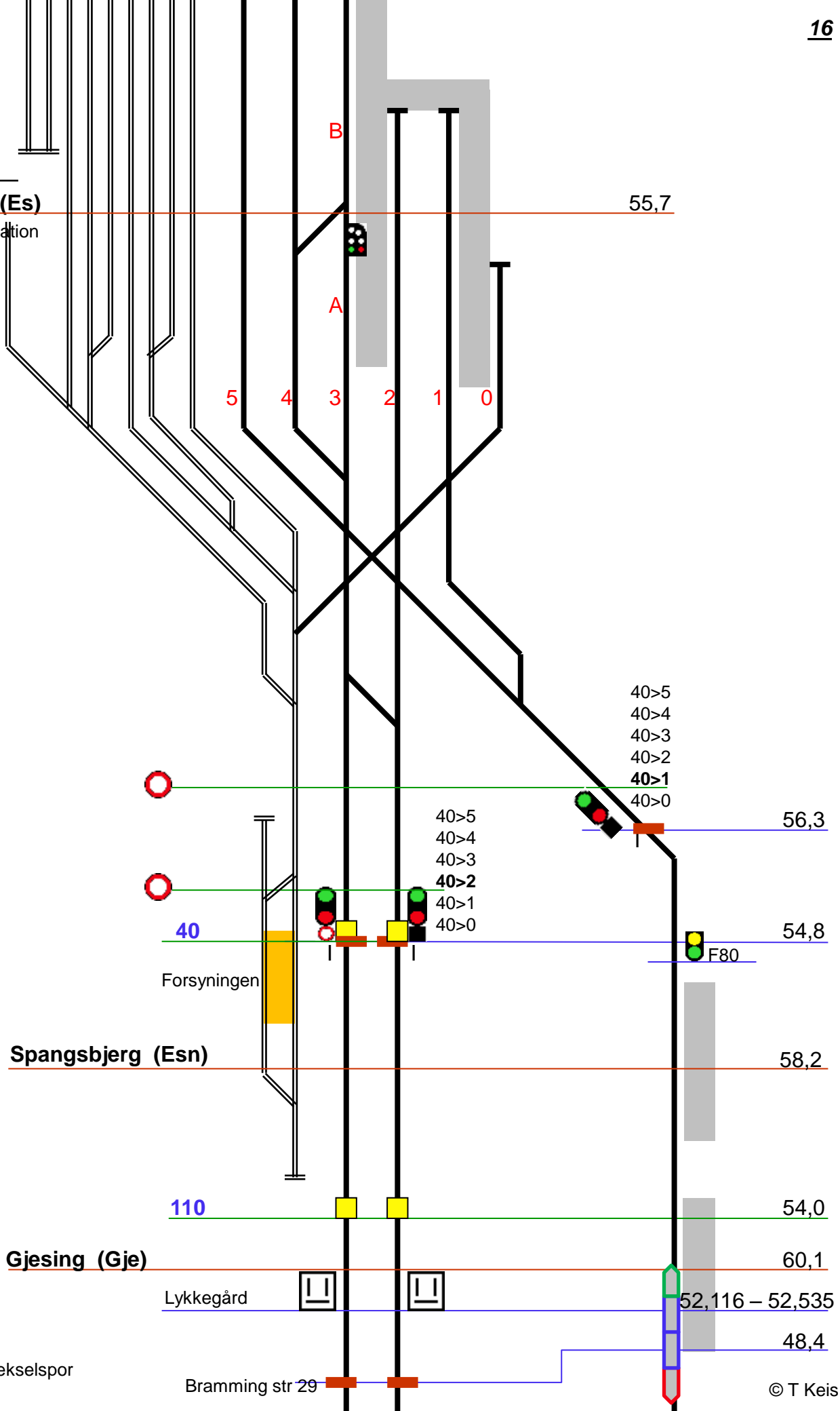

Linieblok  
FC Es

Ovk 119

62,6

62,6



70

U

70

60

Guldager (Gu)

63,3

FC Es

2

1



70>2

60>1

63,8

I



F80

Linieblok  
FC Es

120

71,8



70

U

Varde kaserne (Vka)

72,4



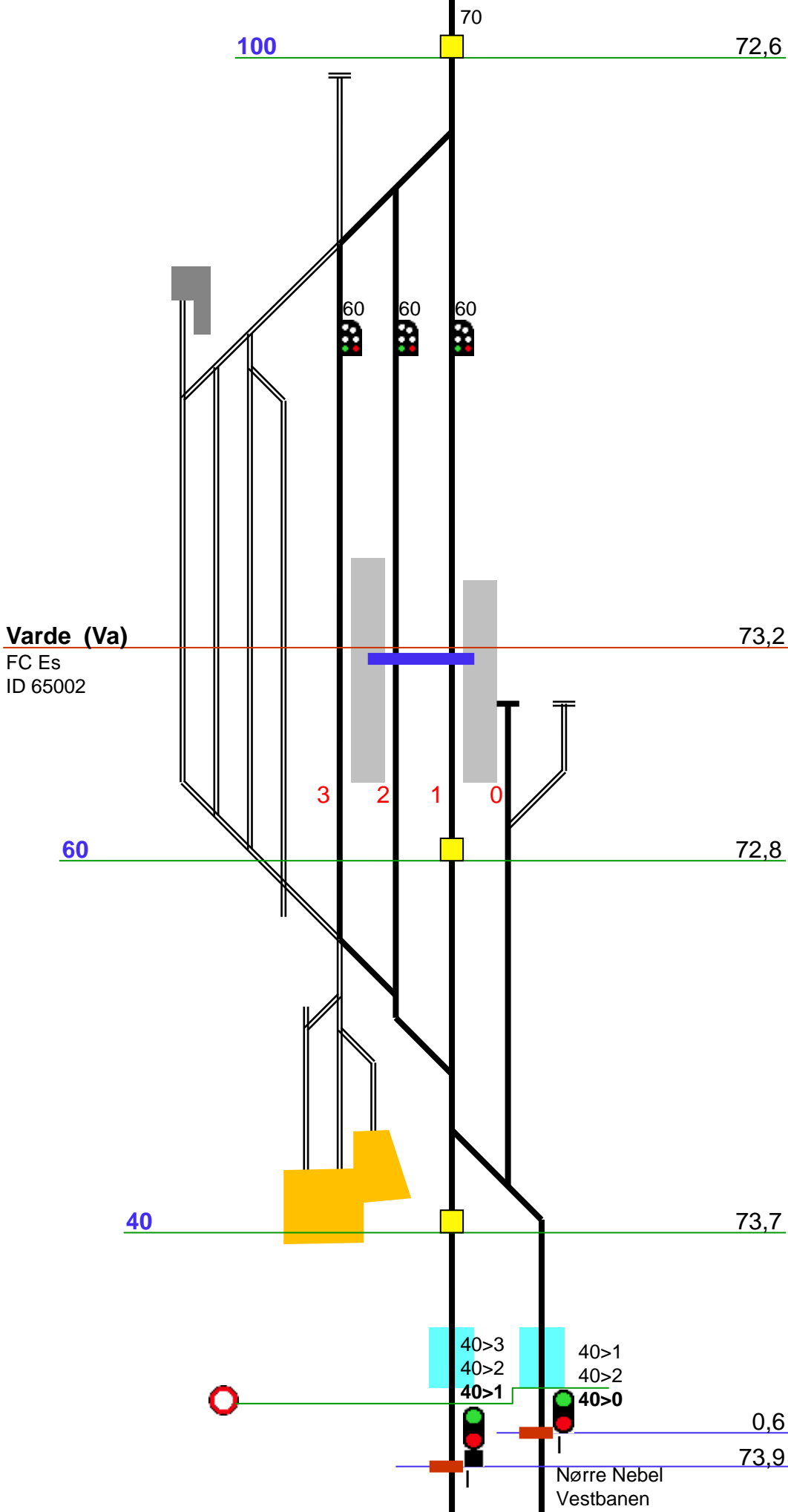

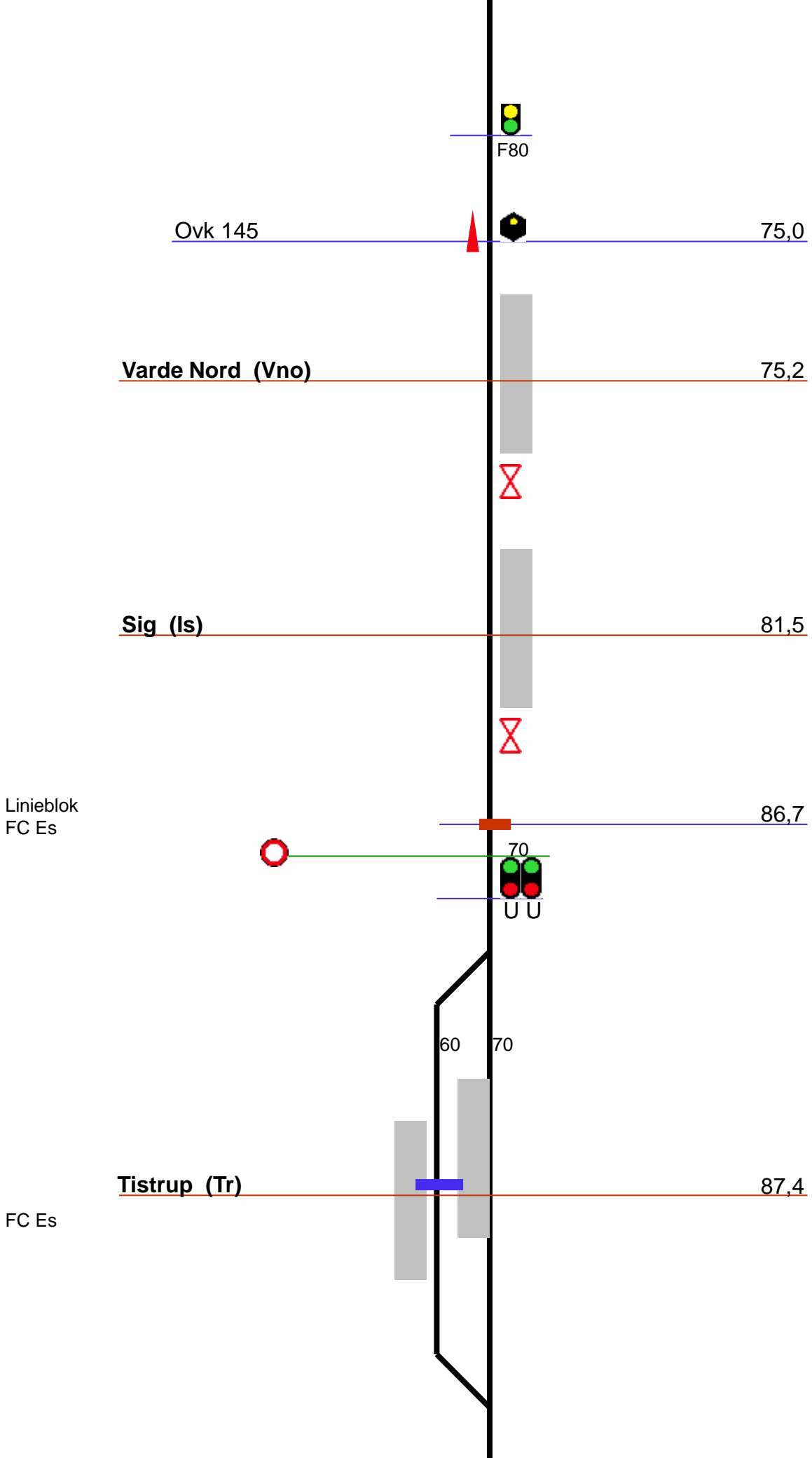

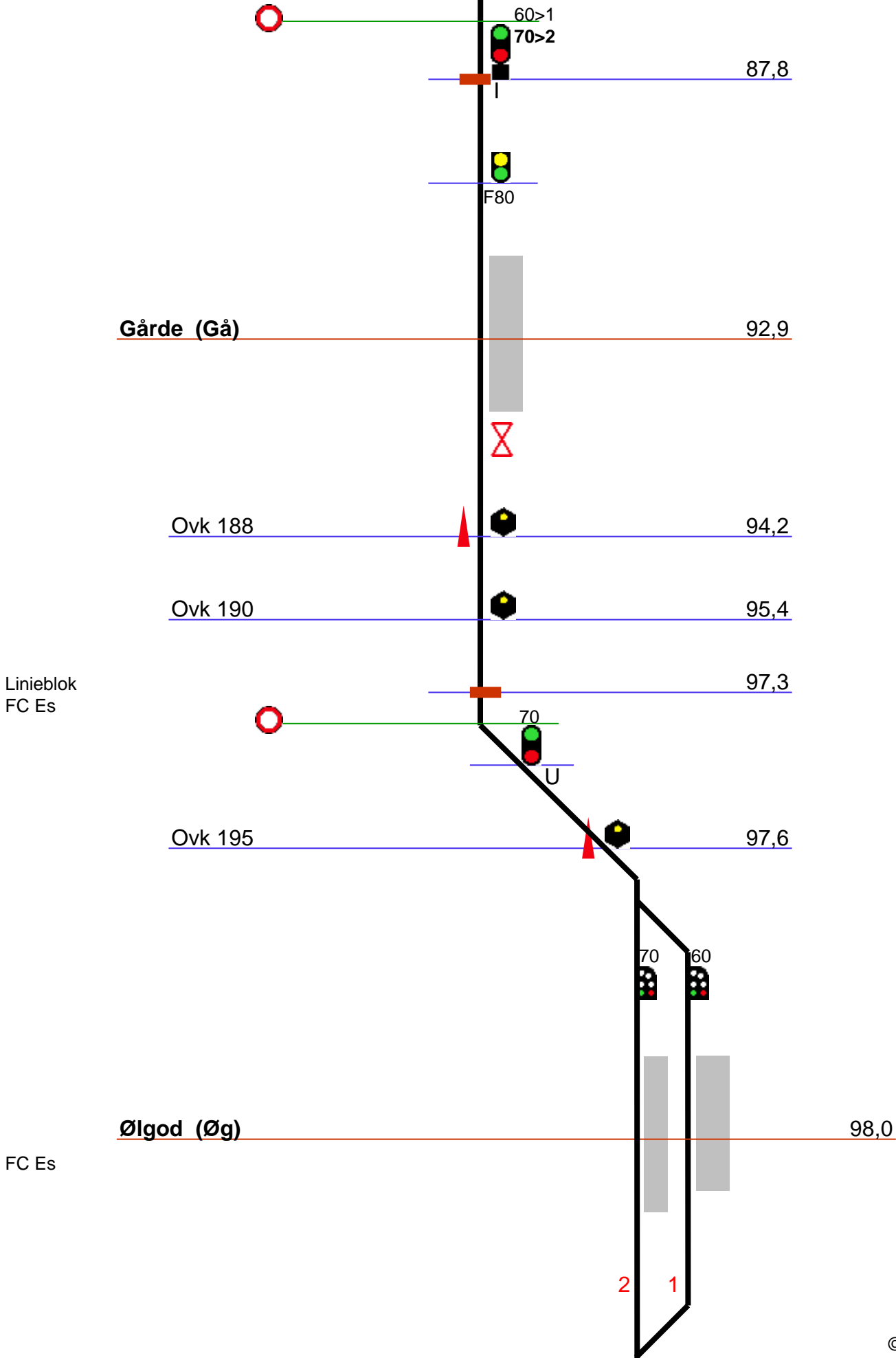

Skanderborg str 35

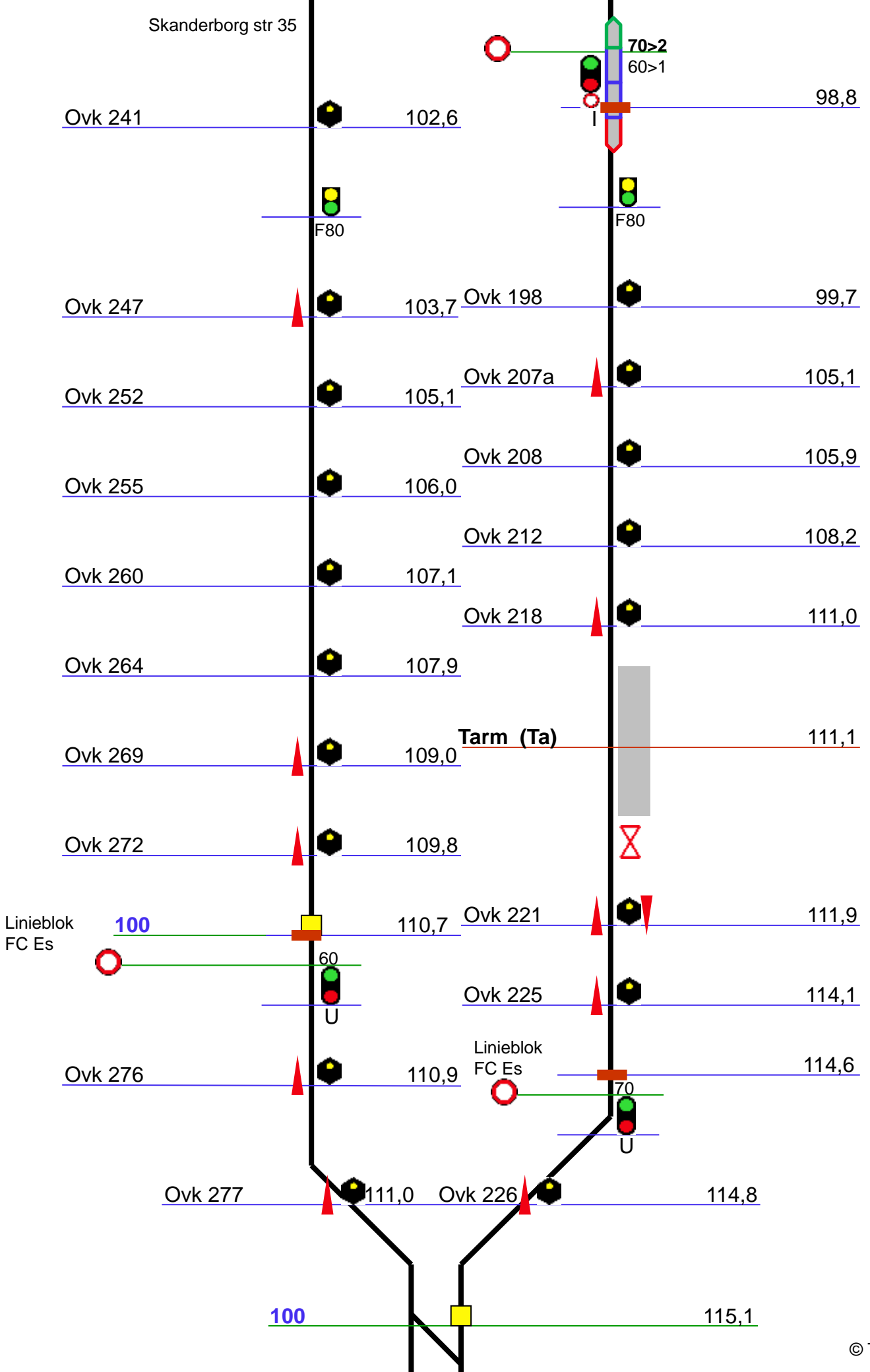

Ovk 227 111,4 / 115,2

90 115,5

60 70 60

V = Varde  
H = Herning

**Skjern (Sj)**

Overgangsstation  
FC Es  
ID 65042

111,9 / 115,6

1 2 3

60>1  
70>2  
60>3

116,6

F80

Ovk 243 123,2

Ovk 246 125,3

Ovk 248 125,9

126,3

Linieblok  
FC Es

70  
U

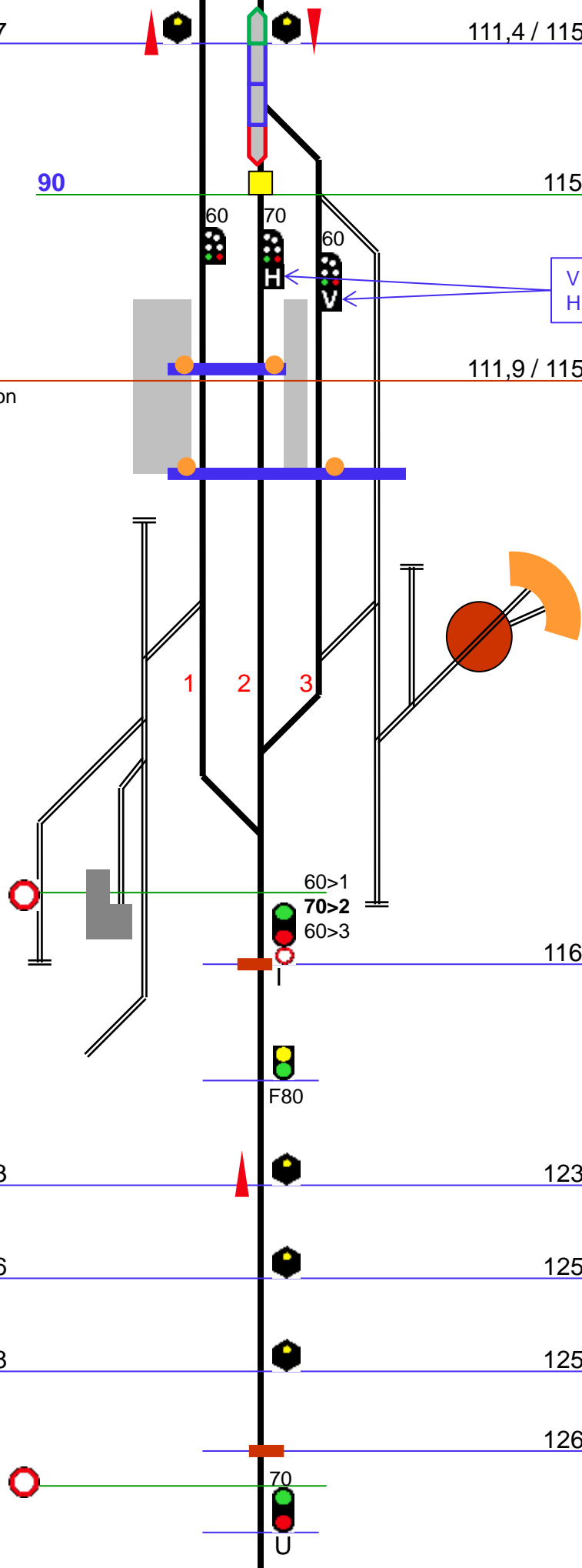



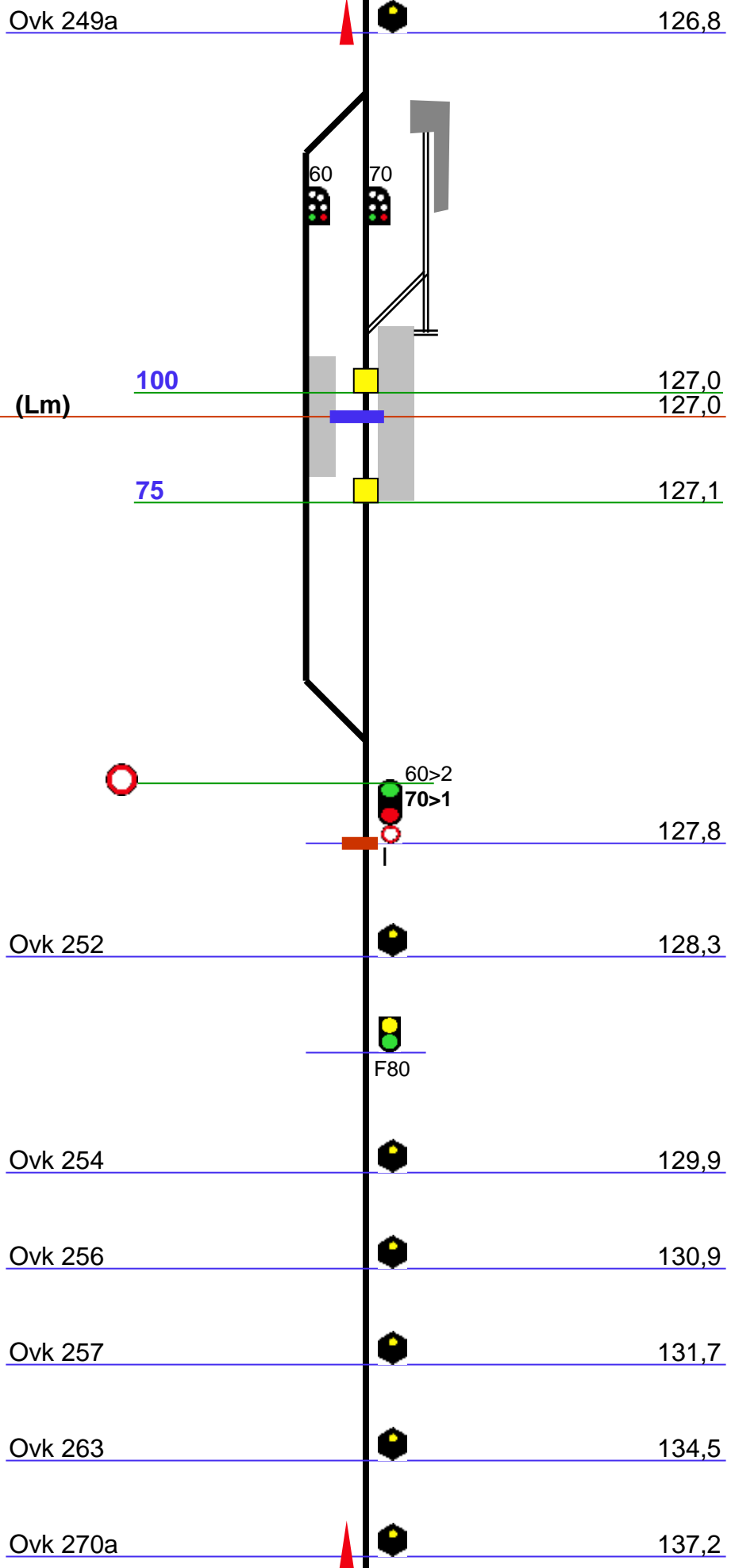

FC Es

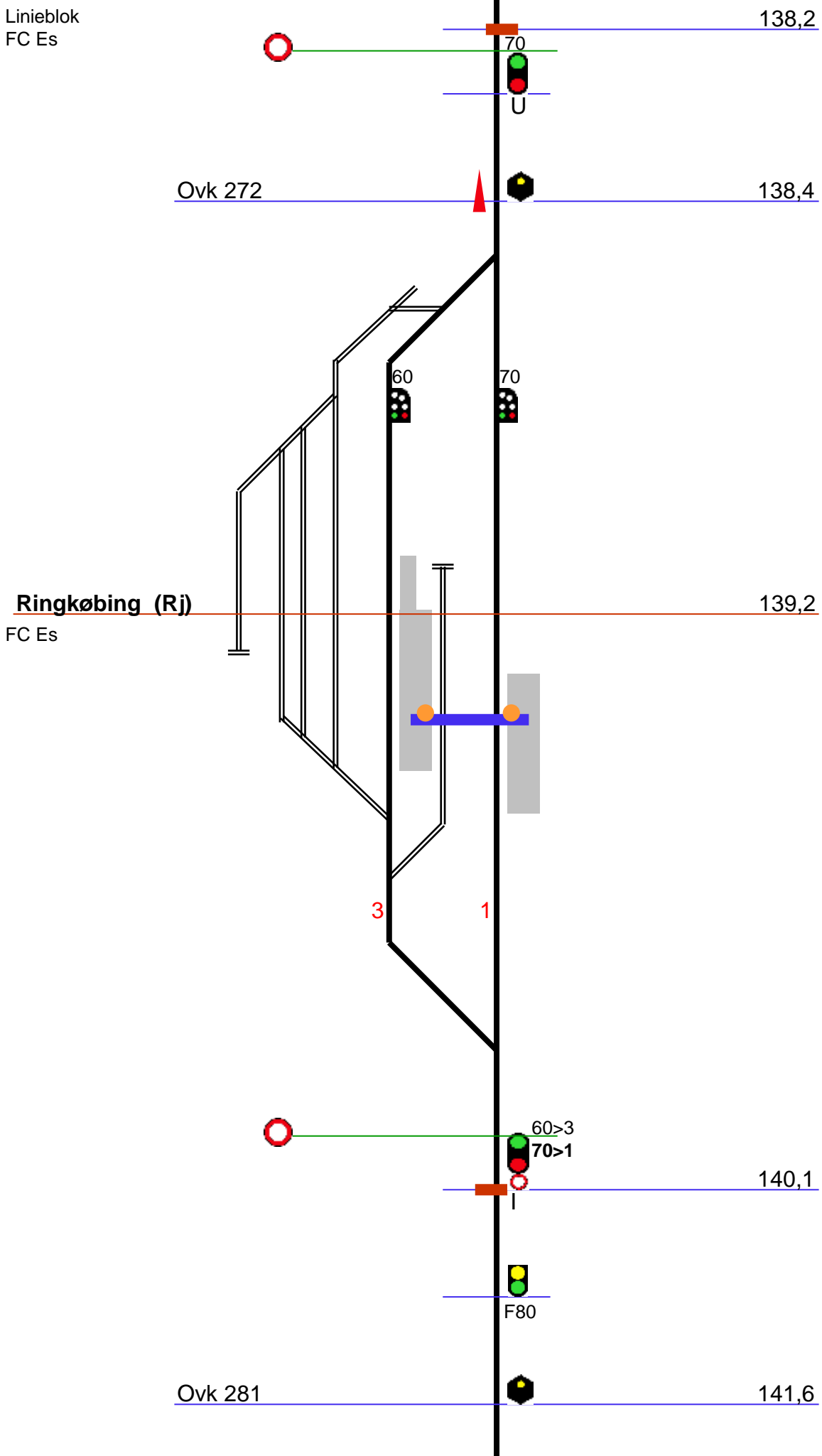

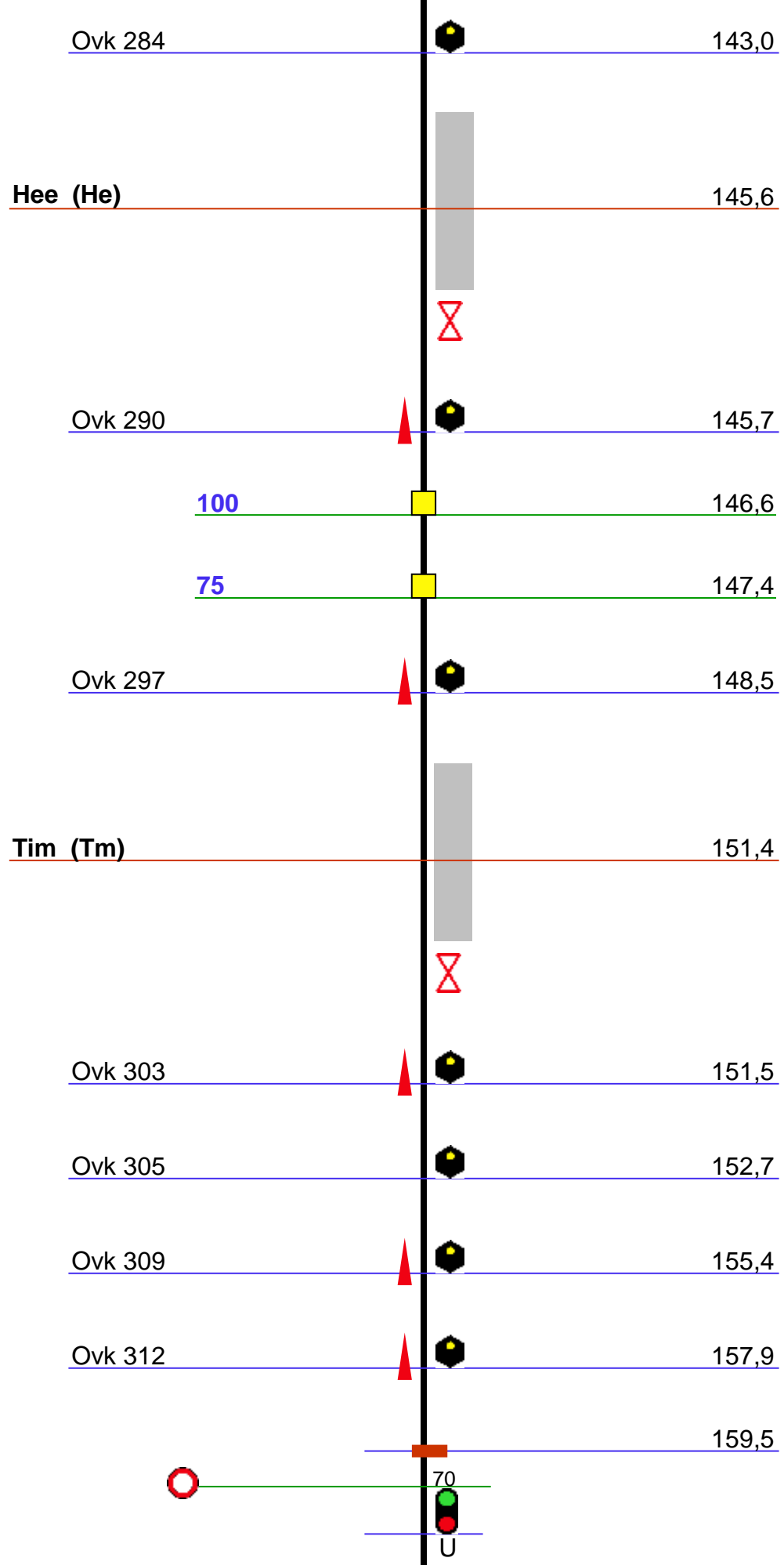

Lineblok  
FC Es

70  
U

FC Es

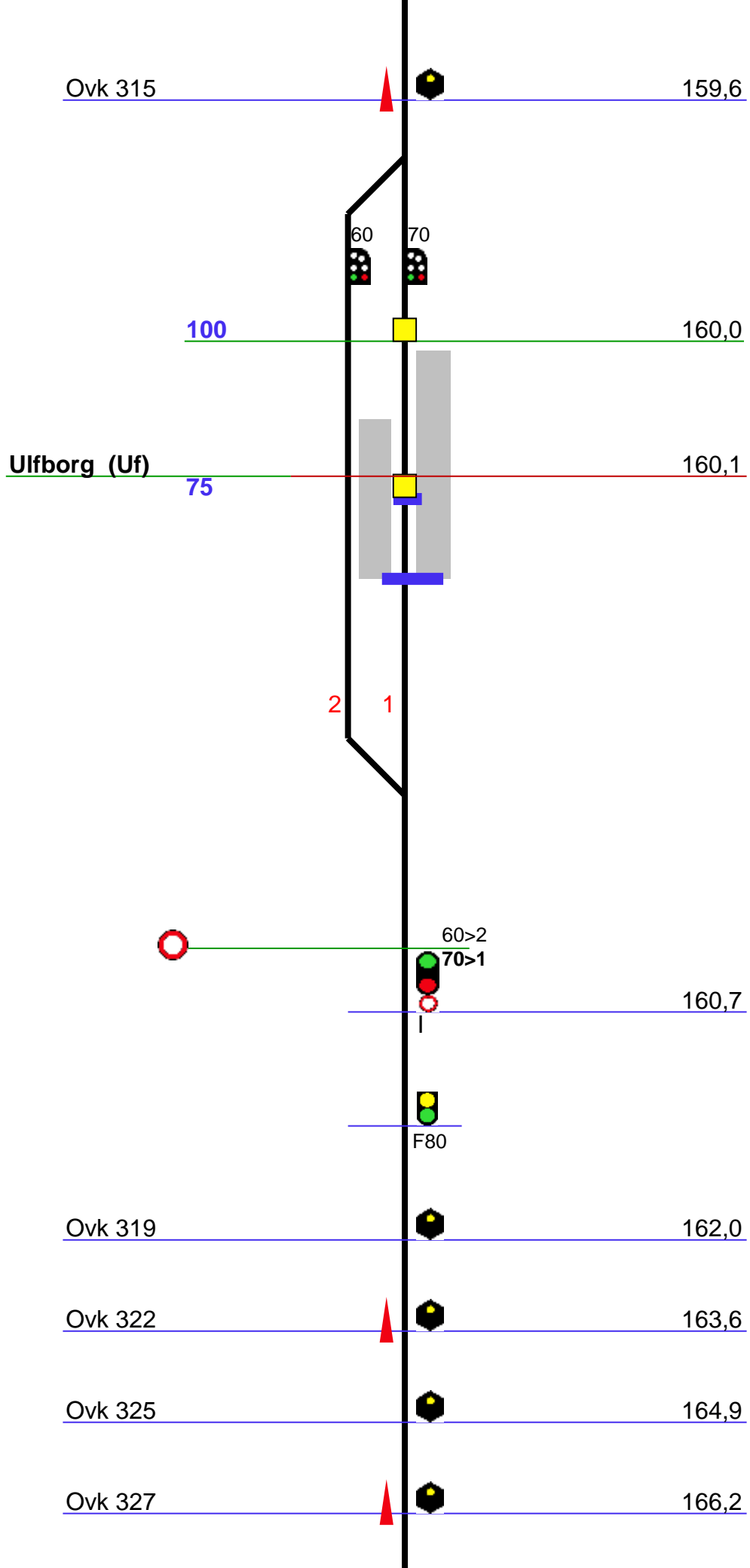

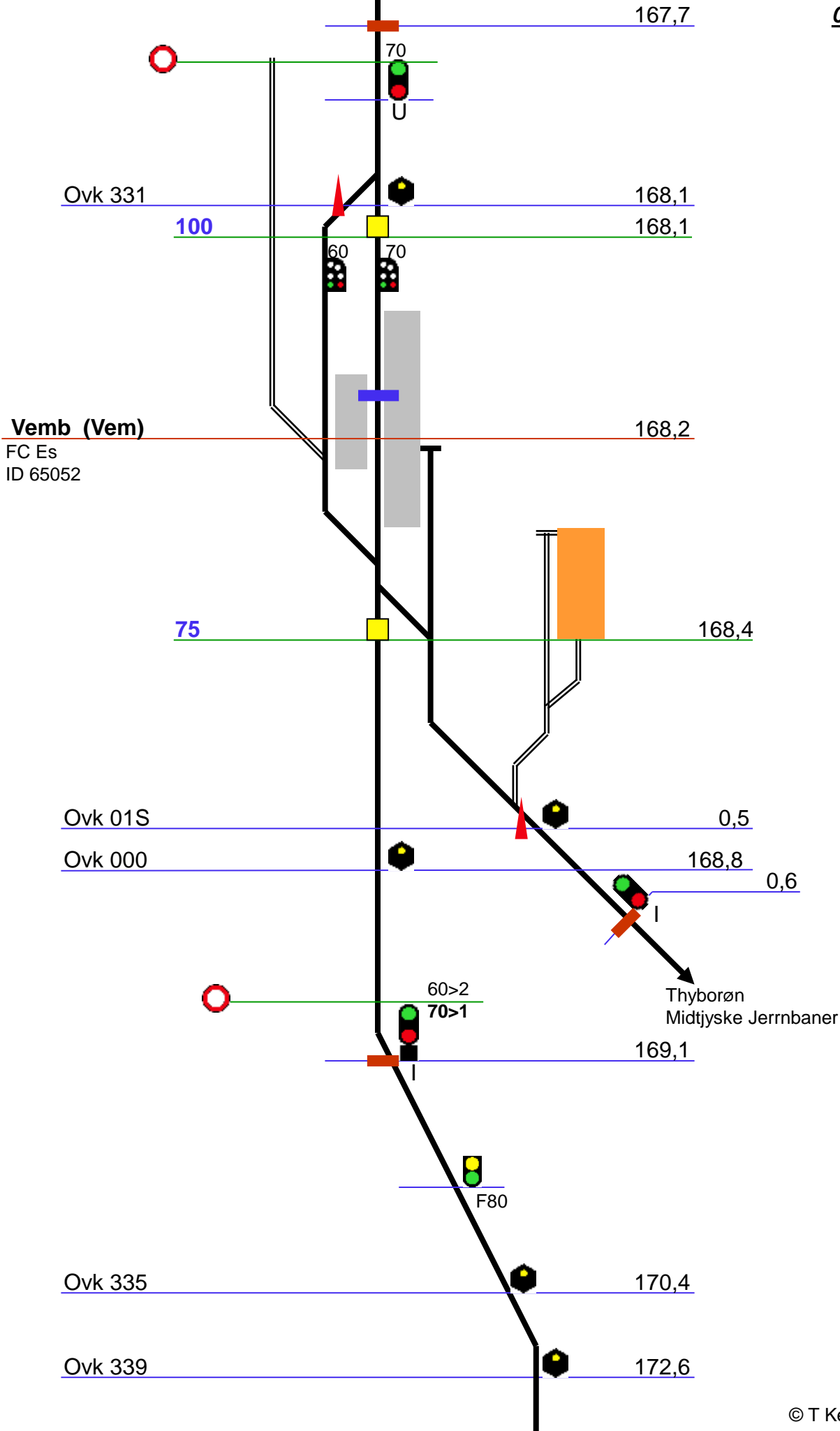

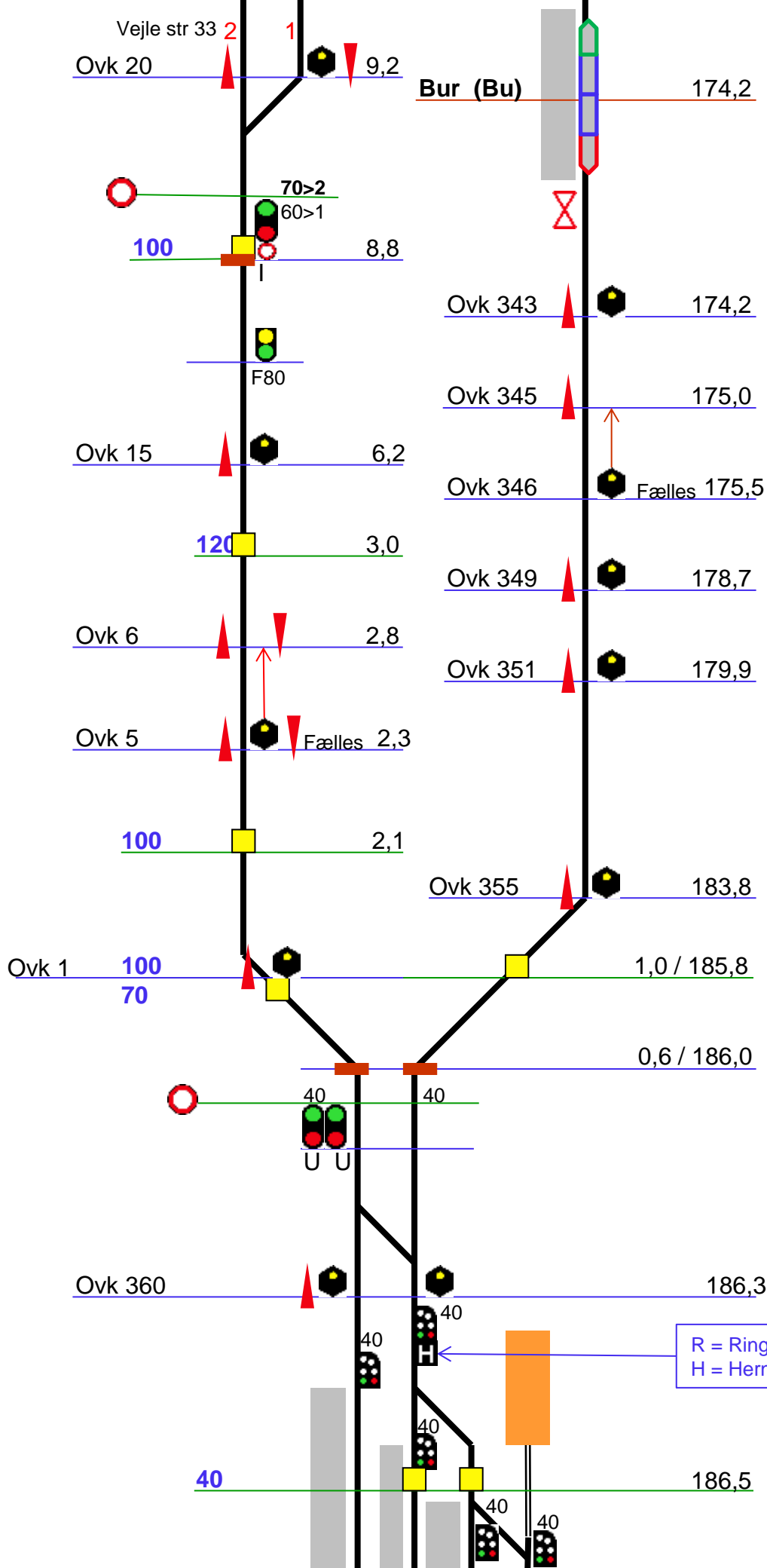

**Holstebro (Ho)**

Overgangsstation  
FC Hr  
ID 67200

186,6

1 2 3 4 5

Ovk 361

187,1

60>1  
40>2  
70>3

187,5

F80

194,5

Linieblok  
FC Ar

70  
U

120

Ovk 377

195,1

195,1

70 60

**Hjerm (Hm)**

195,1

FC Ar

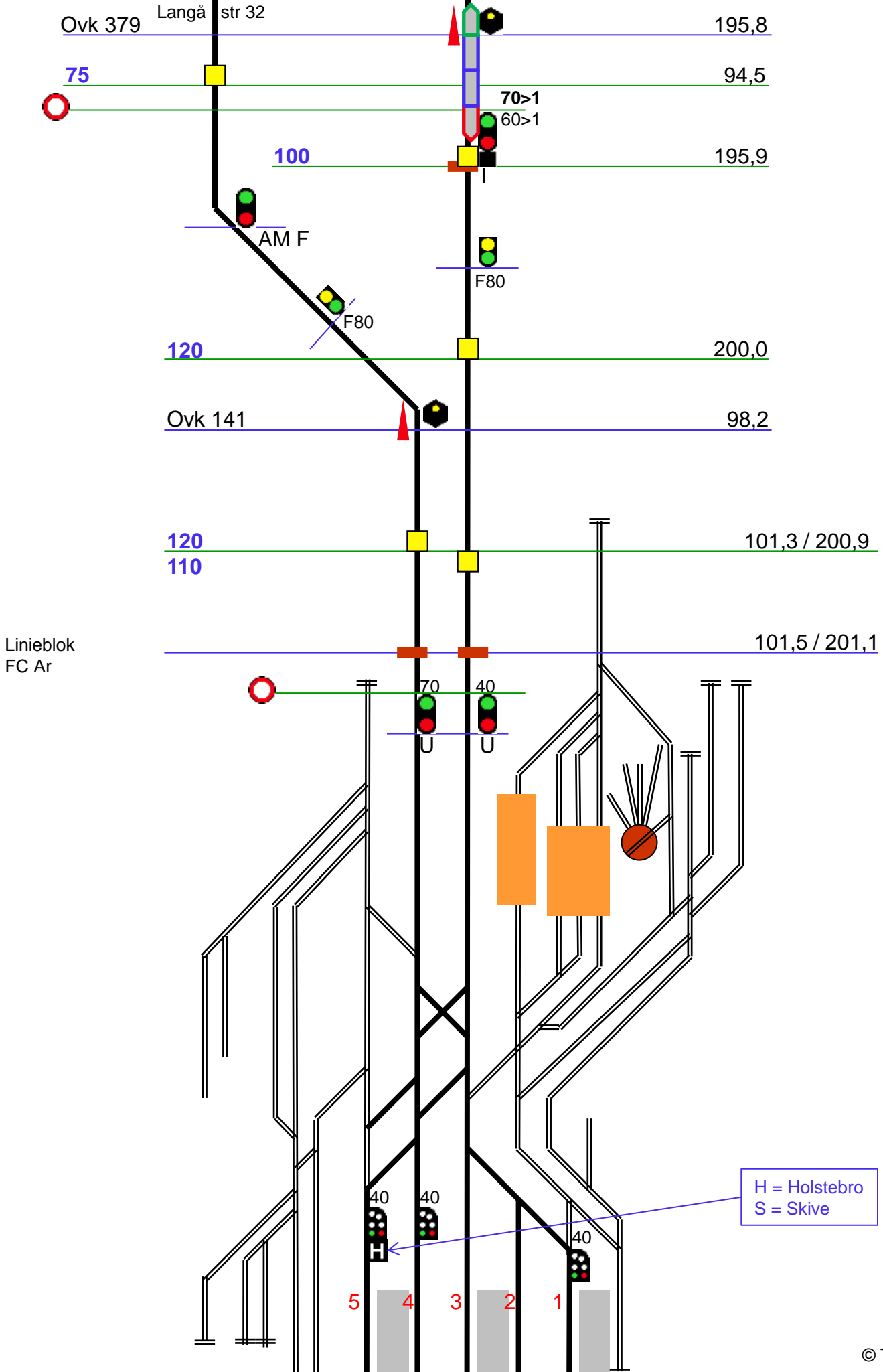



**Struer (Str)**

Overgangsstation  
ID64700

202,1 / 0,0

01

