

Helgoland (Hgl)

Overgangsstation
ID 66100

5,2

- 60 > 2
- 40 > 3-5
- 40 > 7-11
- 40 > 13-15
- 40 > 30

- 40 > 3-5
- 40 > 7-11
- 40 > 13-15
- 40 > 30
- 70 > 1

4,8

Hgl I-B

I-A

4,4

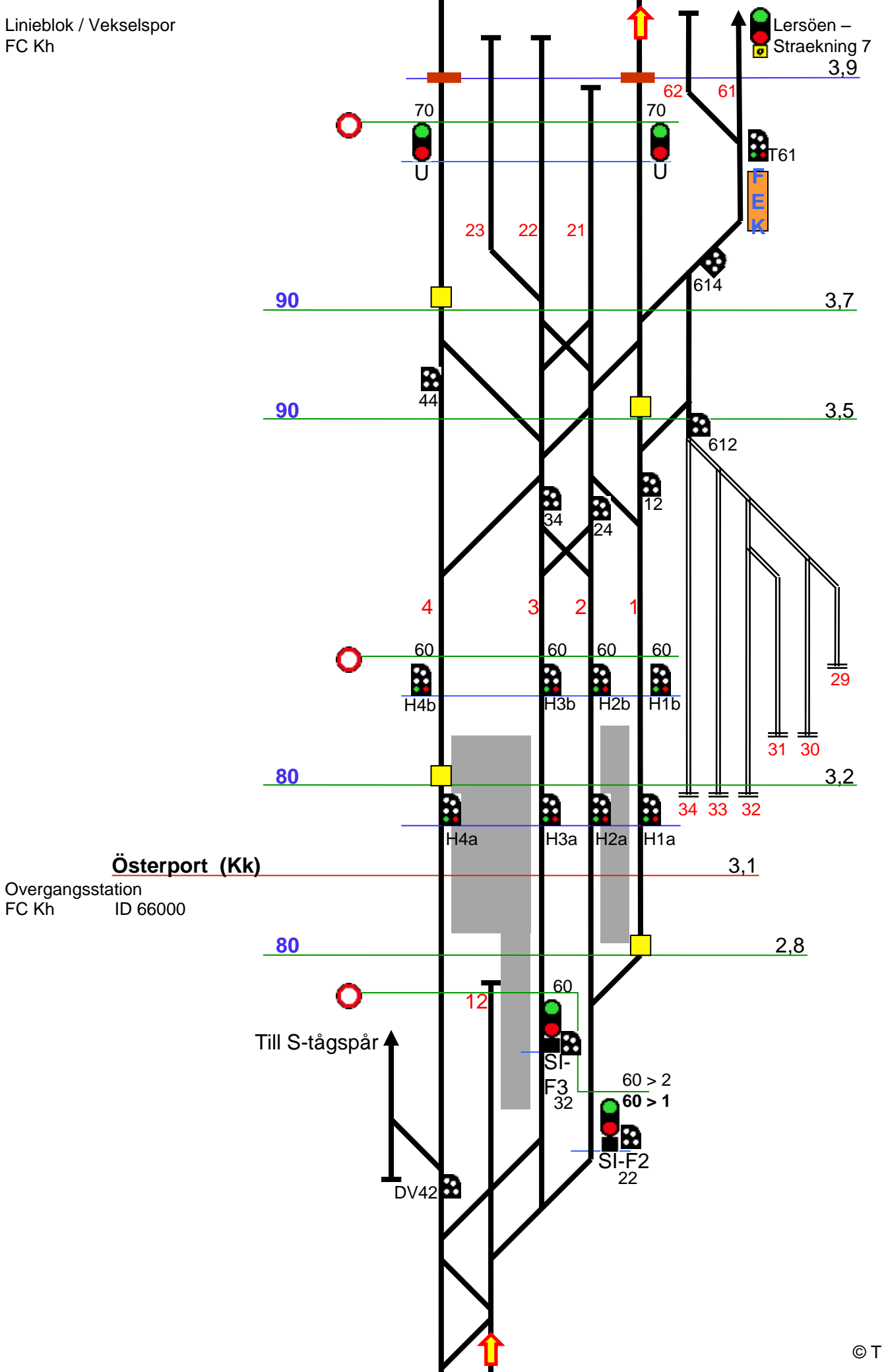

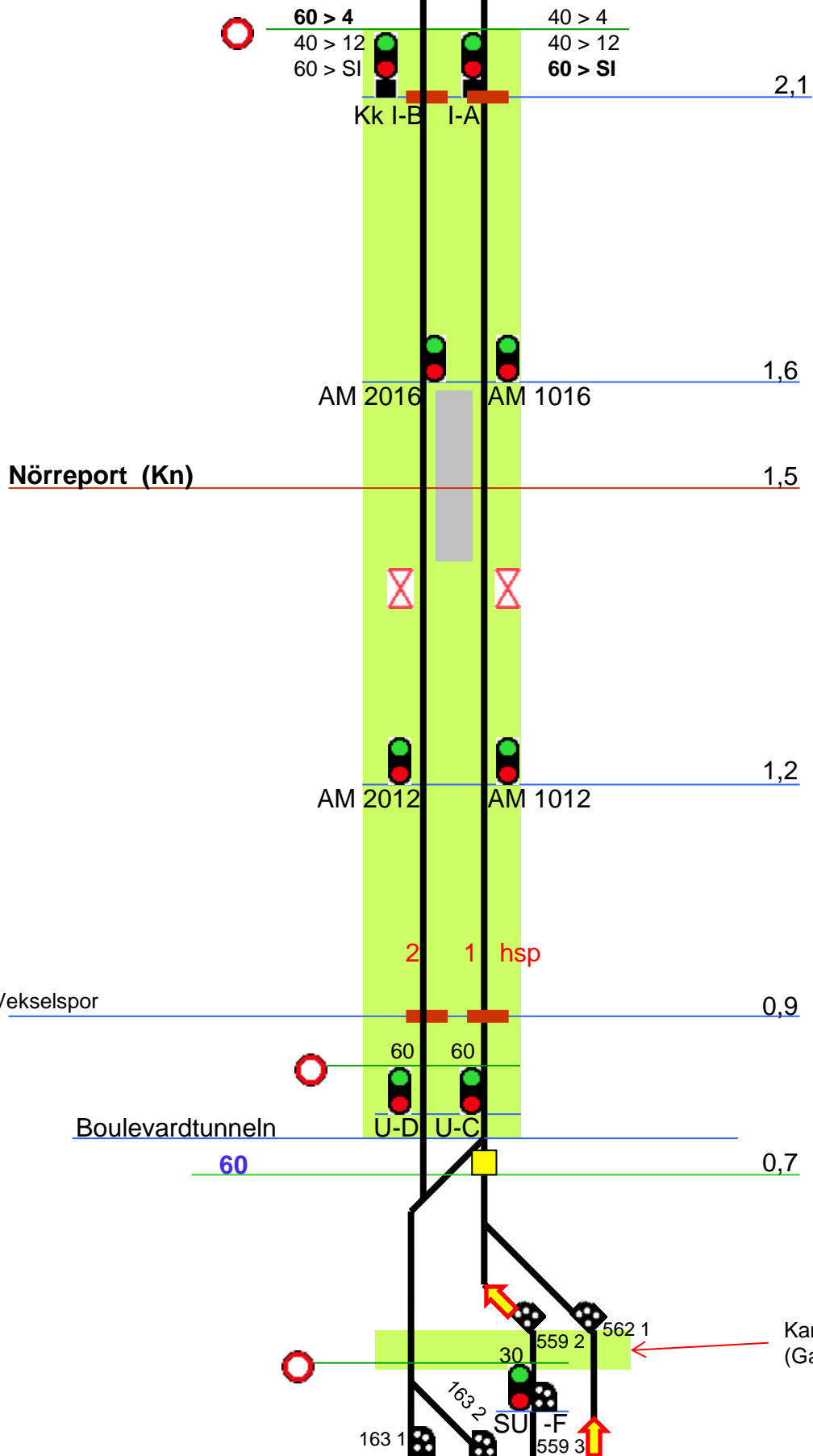

Kampmannsgade (Gatubro)

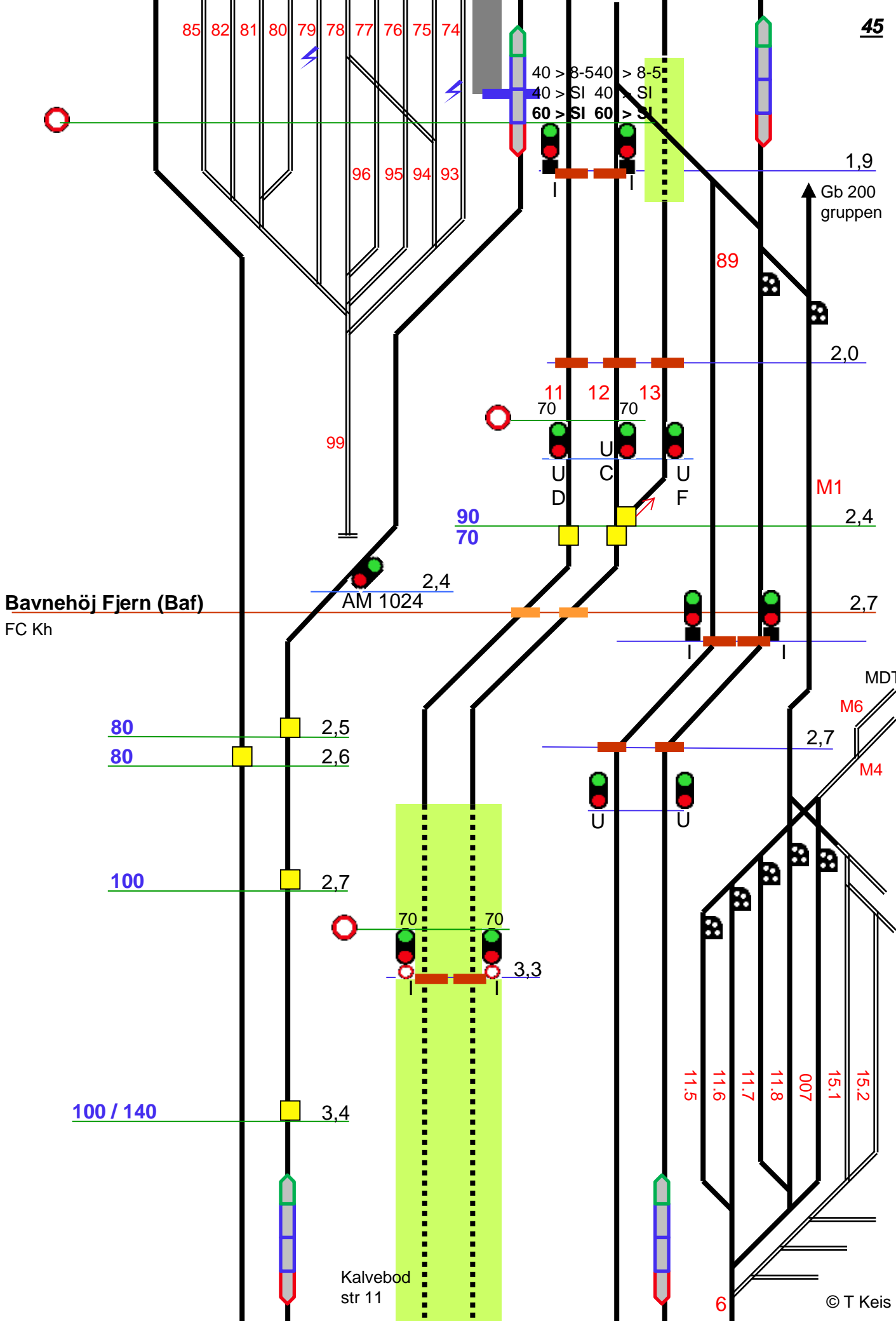

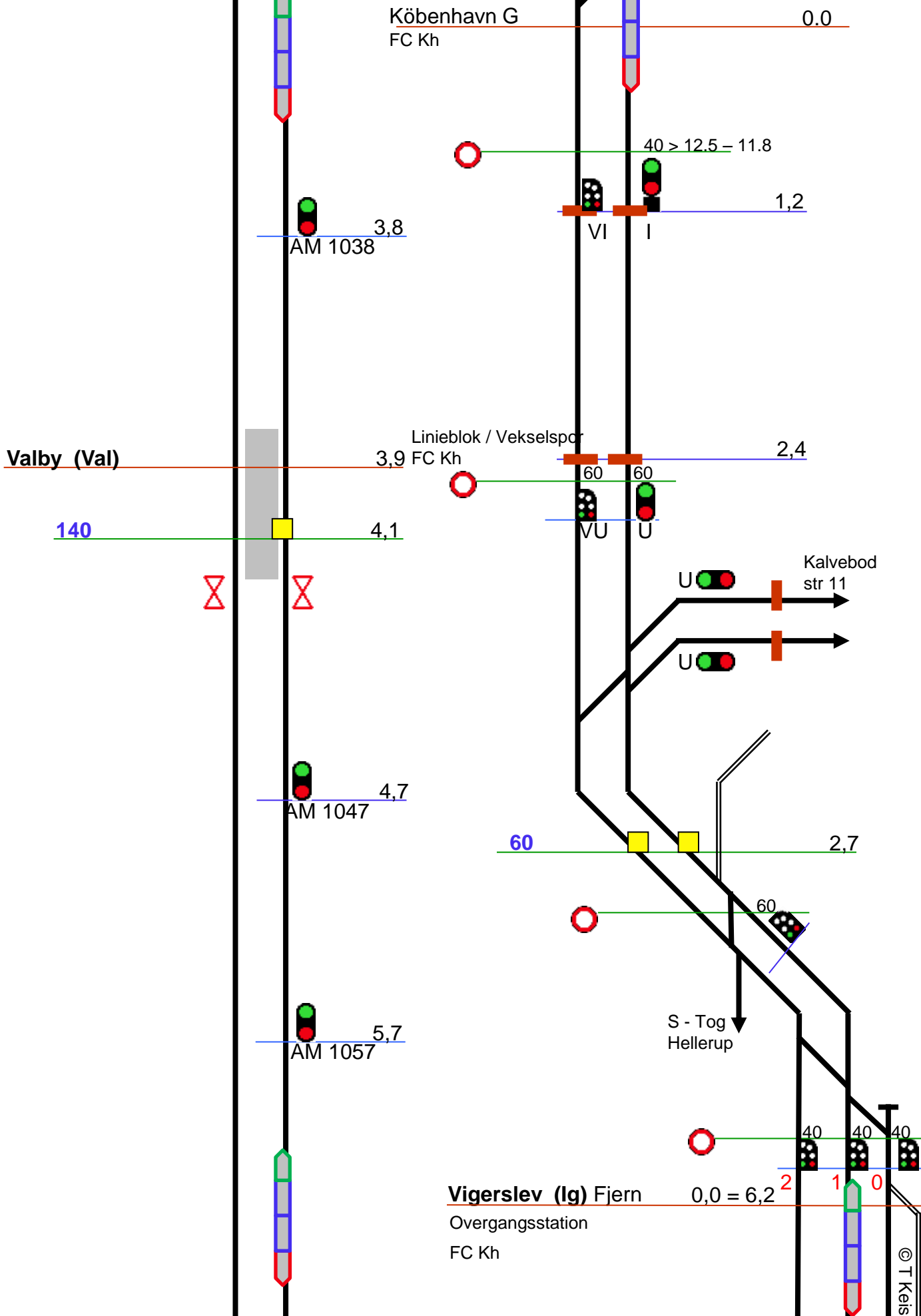

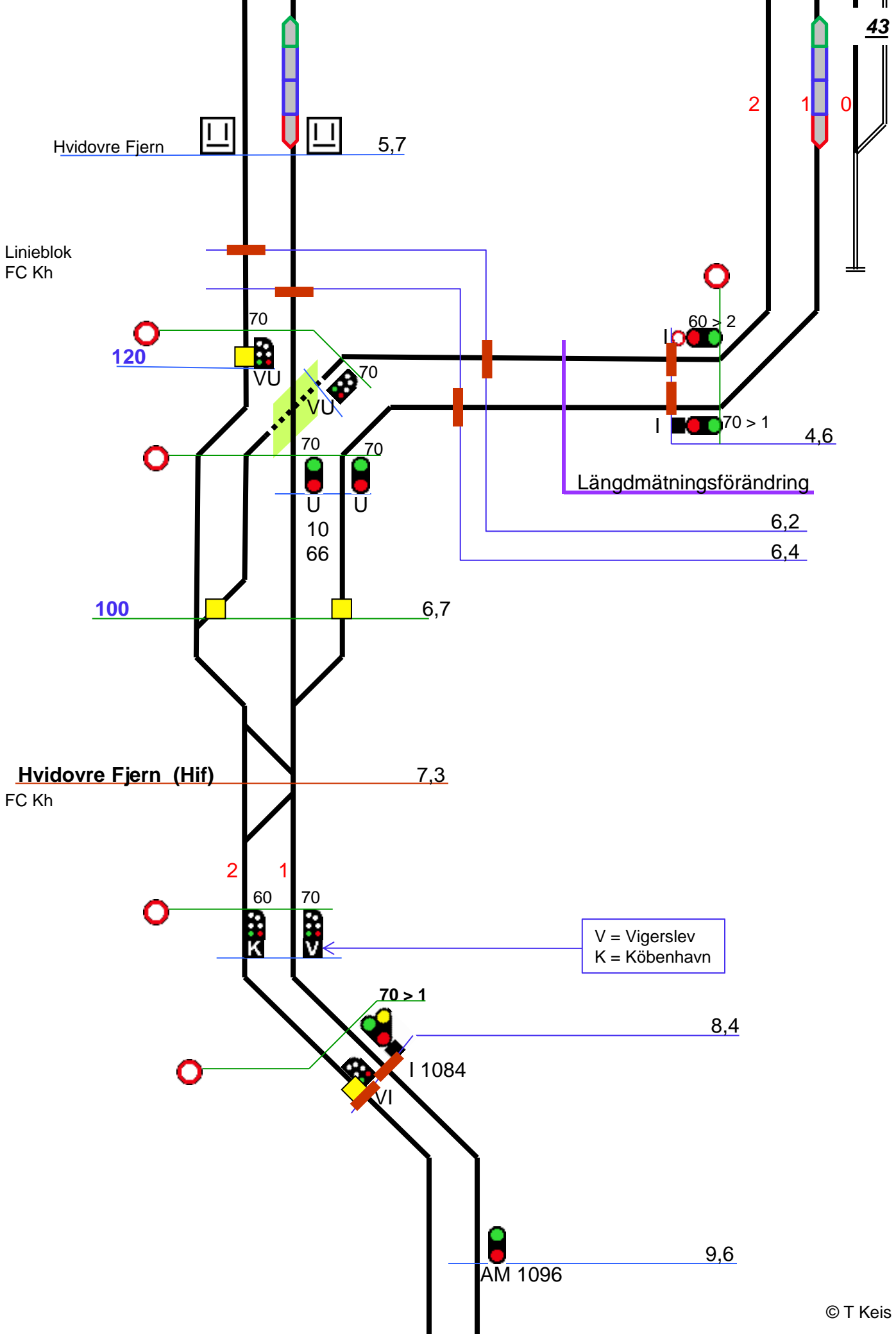

FC Kh

Glostrup (GI)
ID 60001

Linieblok
FC Kh

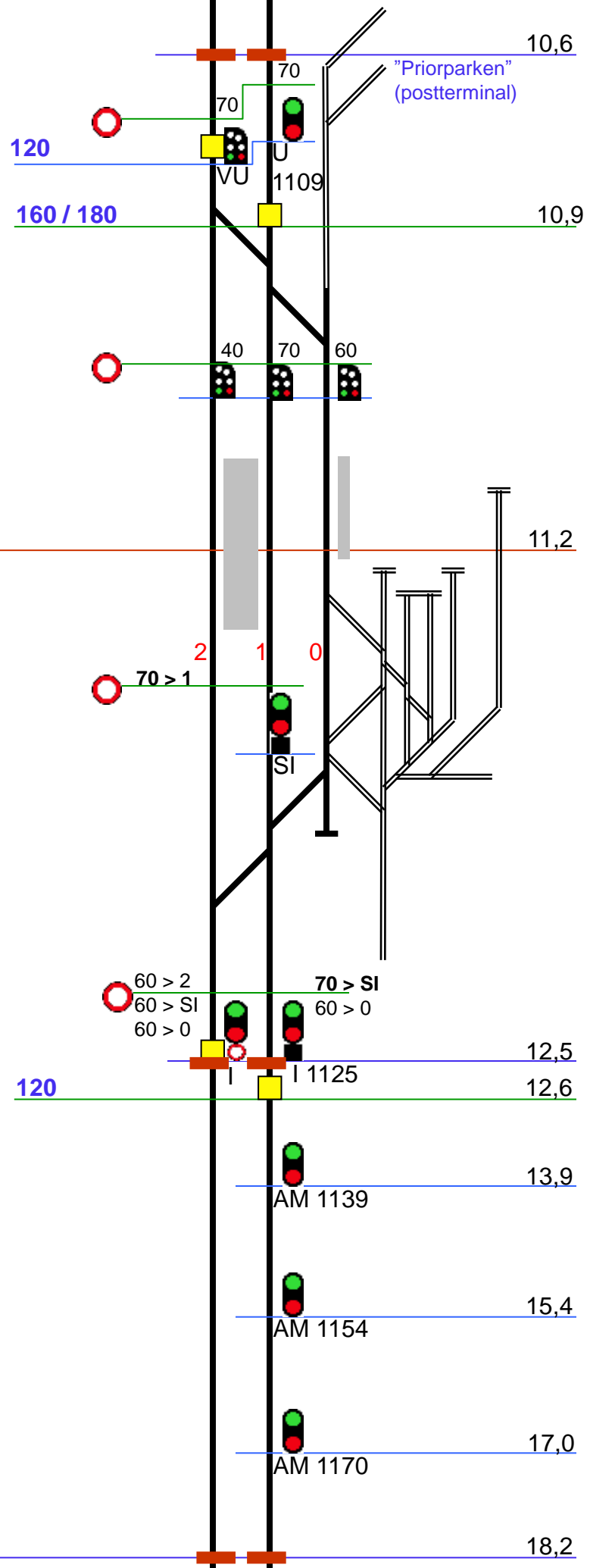

S – Tågen
Sträcka 8.2
København H

Høje Taastrup (Htå)
Overgangsstation
FC Ro Øst ID 61001

	> 5	4	3	2	1	0
hsp 4	60	70	60	60	60	60
hsp 3	60	60	70	60	60	60
hsp 2	60	60	60	70	60	60
hsp 1	60	60	60	60	70	60

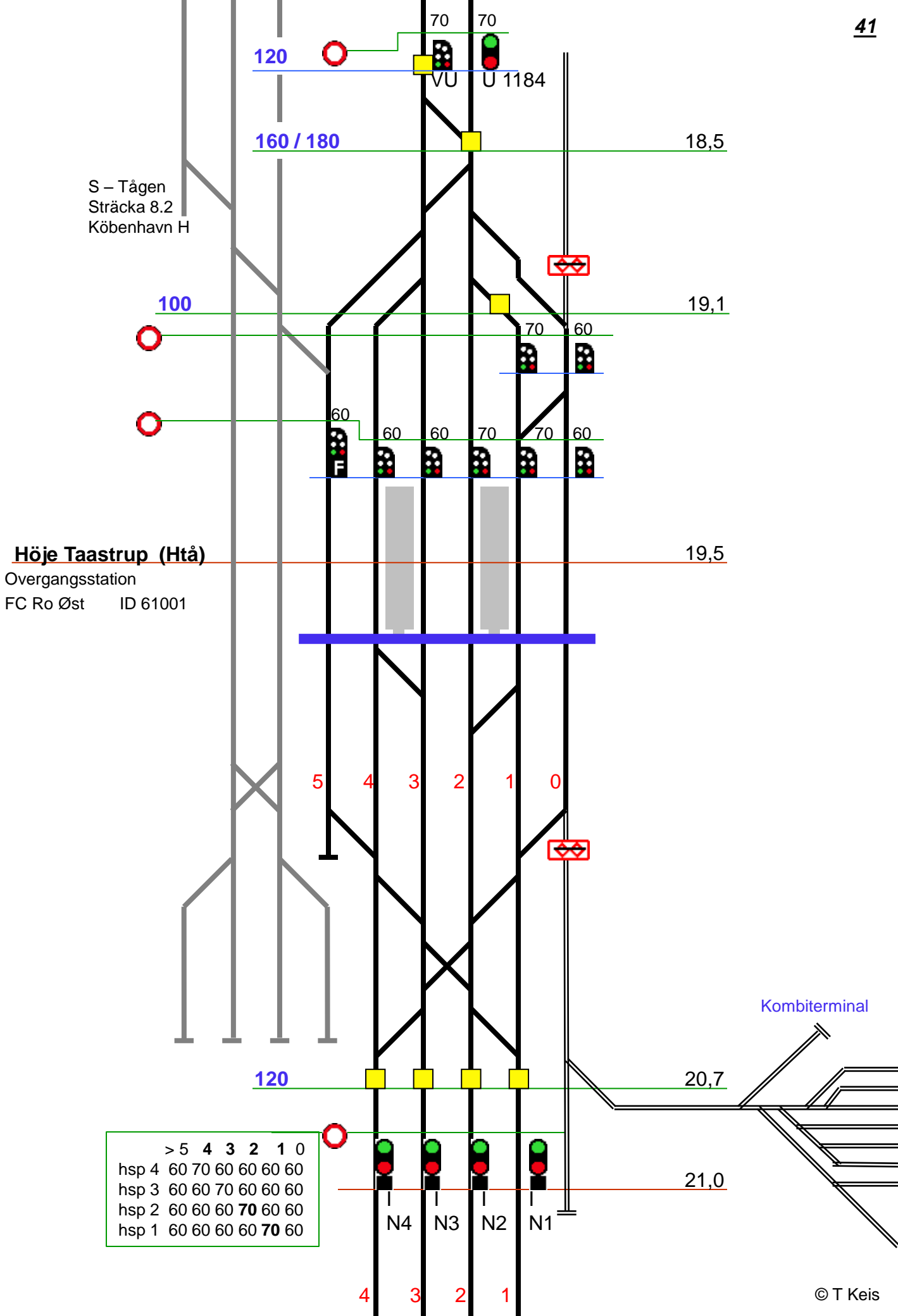

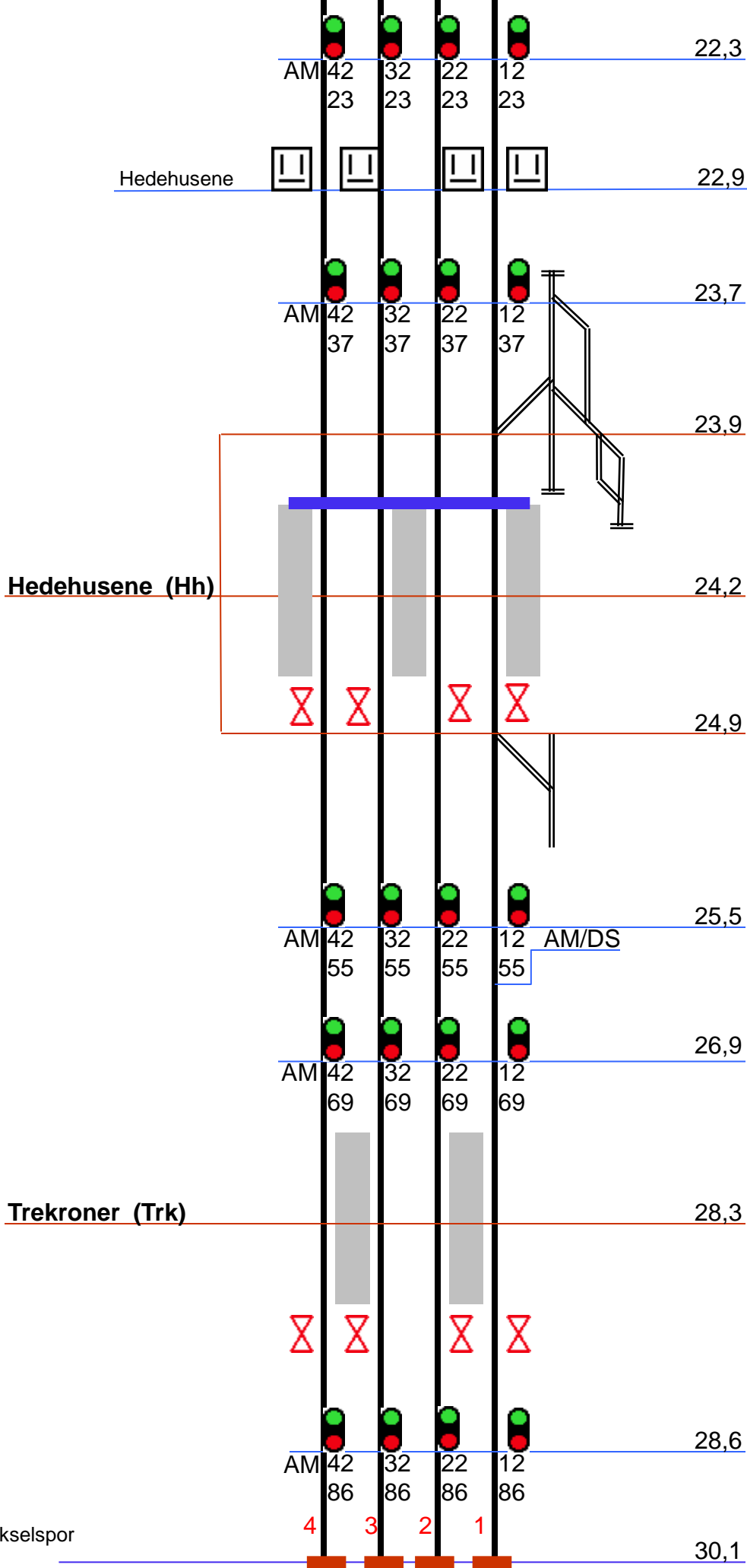

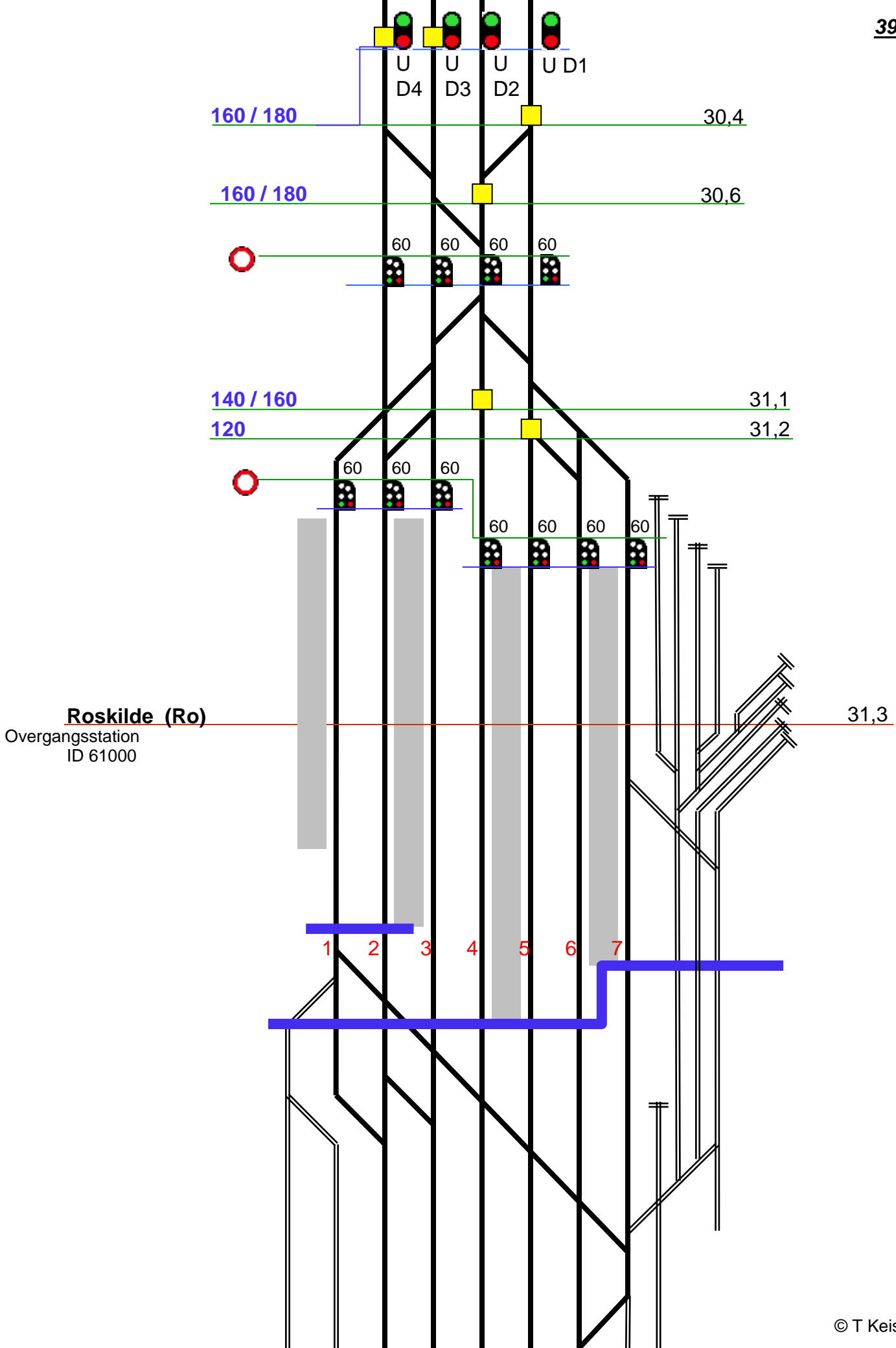

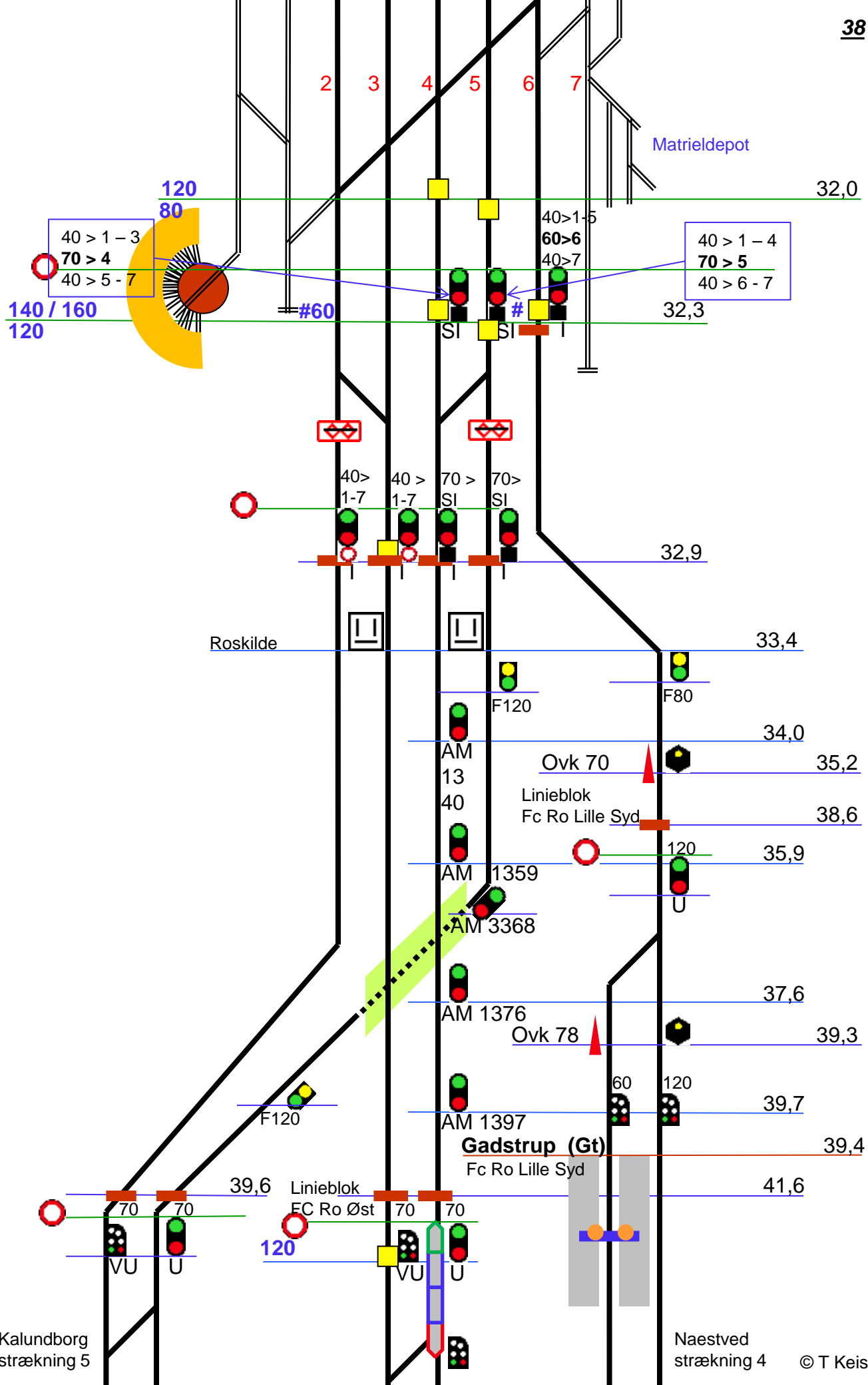

Kalundborg strækning 5

Næstved strækning 4

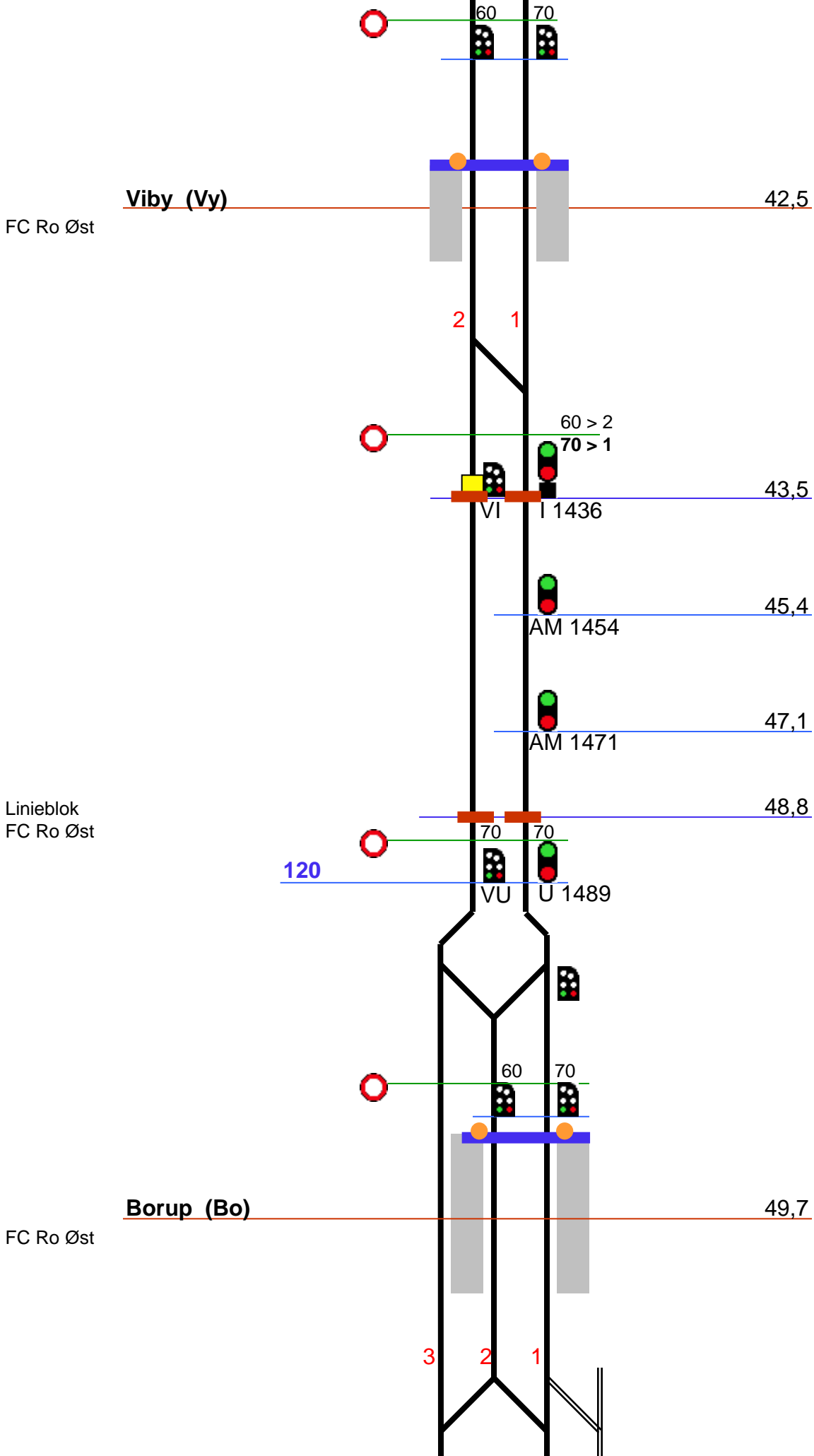

Linieblok
FC Ro Øst

FC Ro Øst

Linieblok
FC Ro Øst

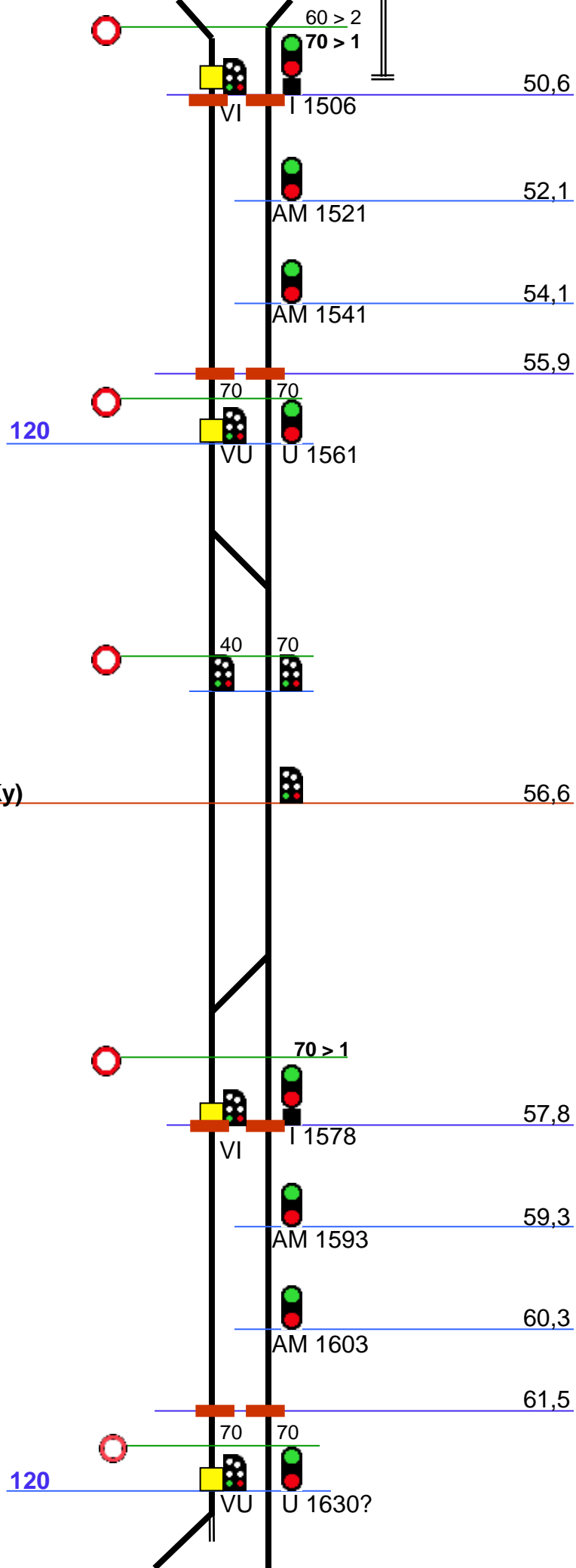

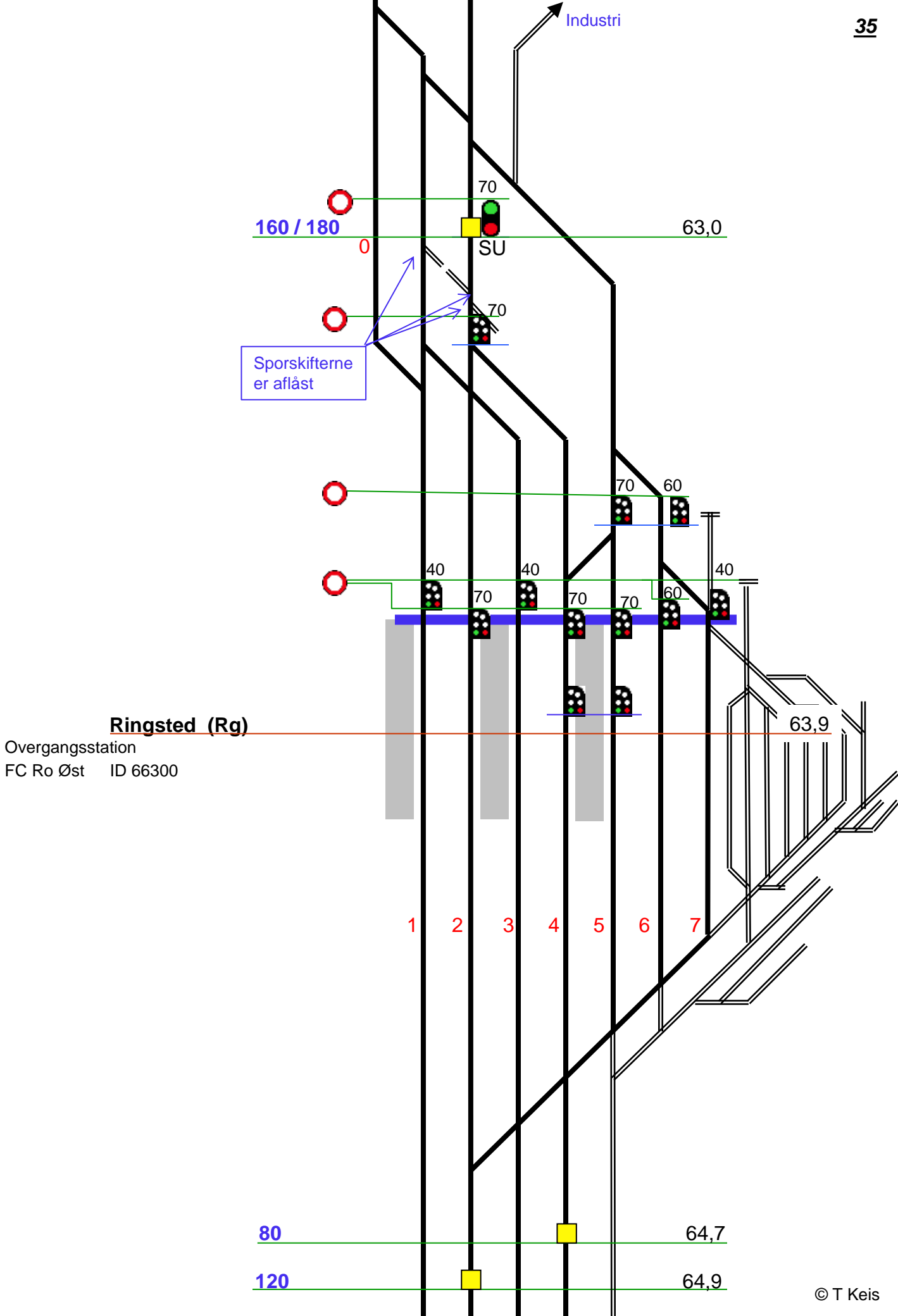

160 / 180

0

70

SU

63,0

Sporskifterne er aflåst

70

70

60

70

40

40

70

70

70

60

40

Ringsted (Rg)

Overgangsstation
FC Ro Øst ID 66300

63,9

1

2

3

4

5

6

7

80

64,7

120

64,9

Linieblok
FC Ro Vest

FC Ro Vest

Fjenneslev (Fj)

Glumsø (Gz)

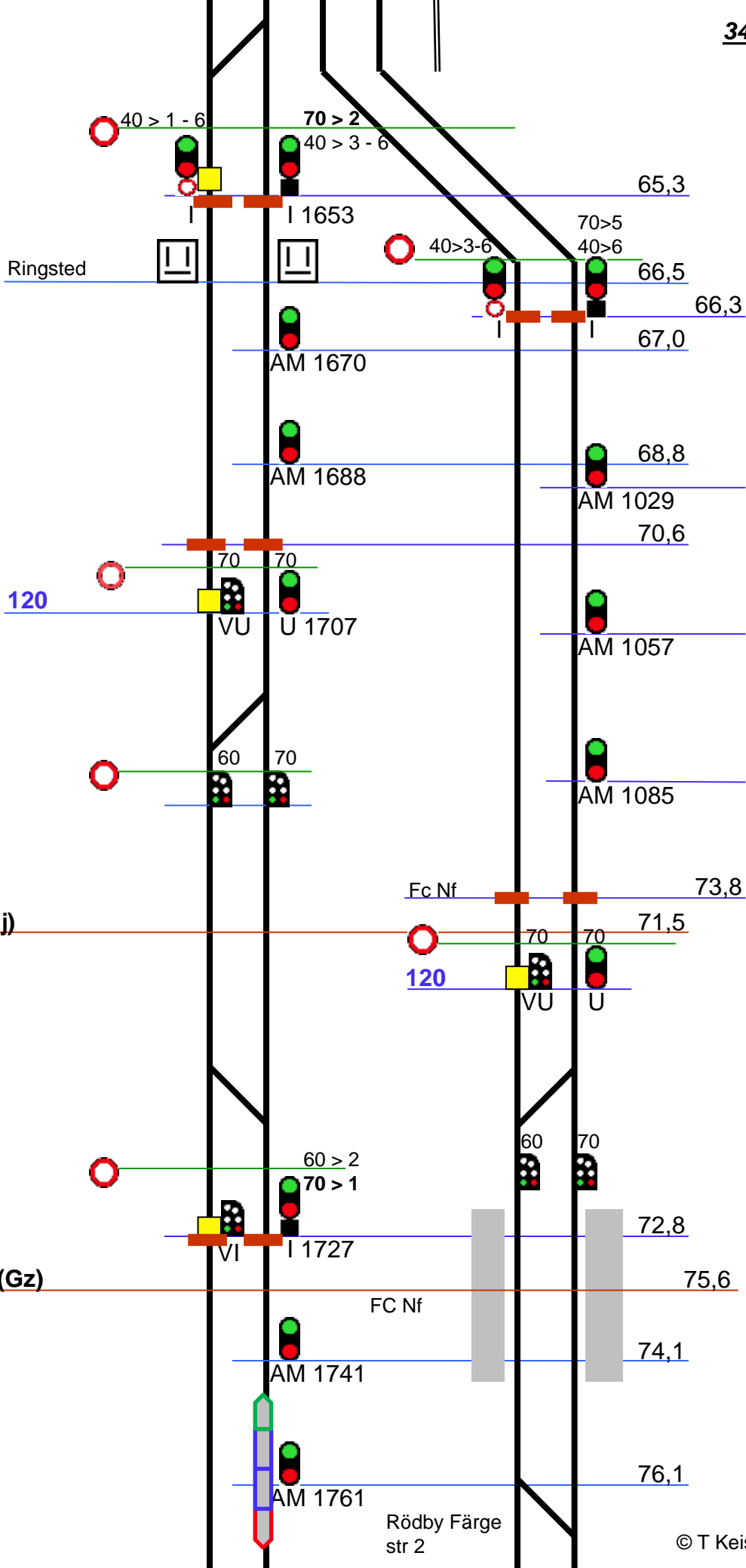

Linieblok
FC Ro Vest

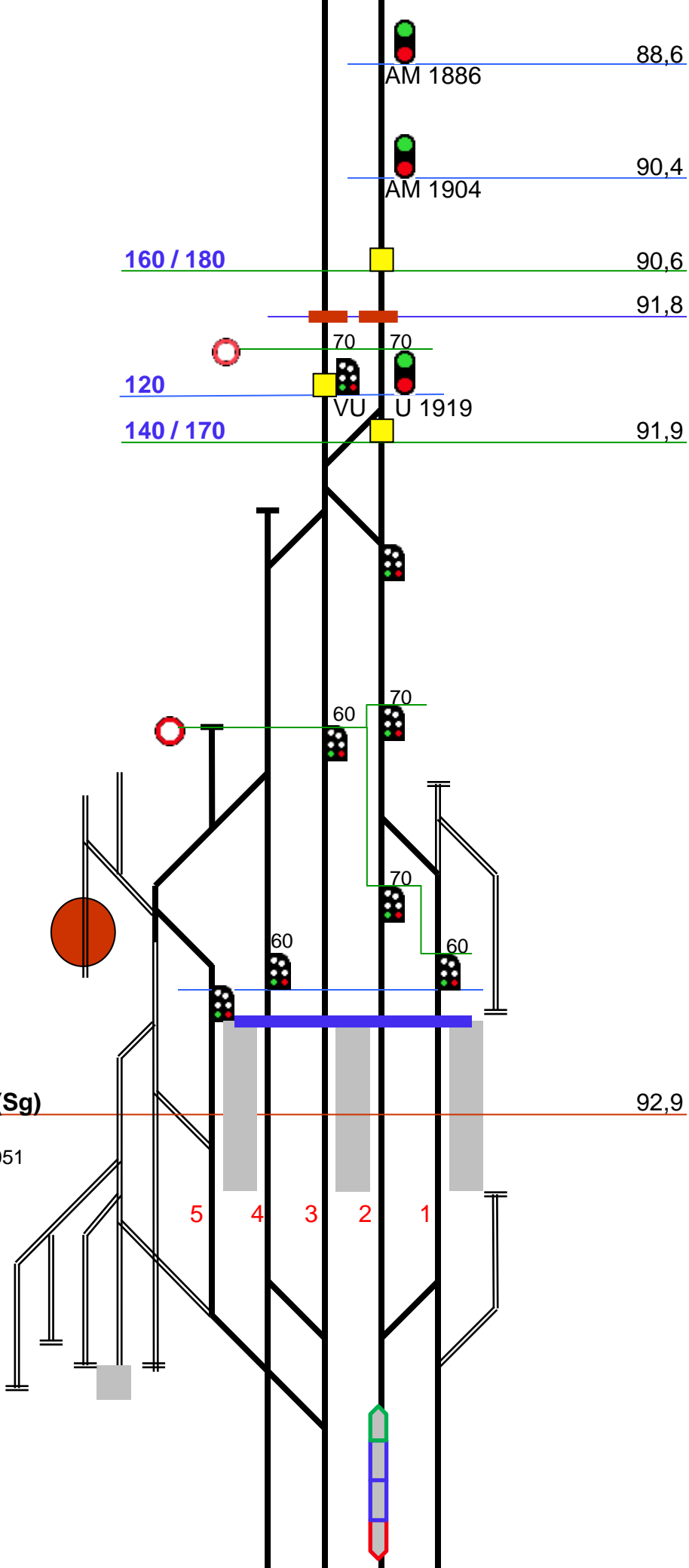

88,6

AM 1886

90,4

AM 1904

160 / 180

90,6

91,8

120

70

70

140 / 170

VU

U 1919

91,9

60

70

60

70

60

Slagelse (Sg)

92,9

Overgangsstation
FC Ro Vest ID 61051

5

4

3

2

1

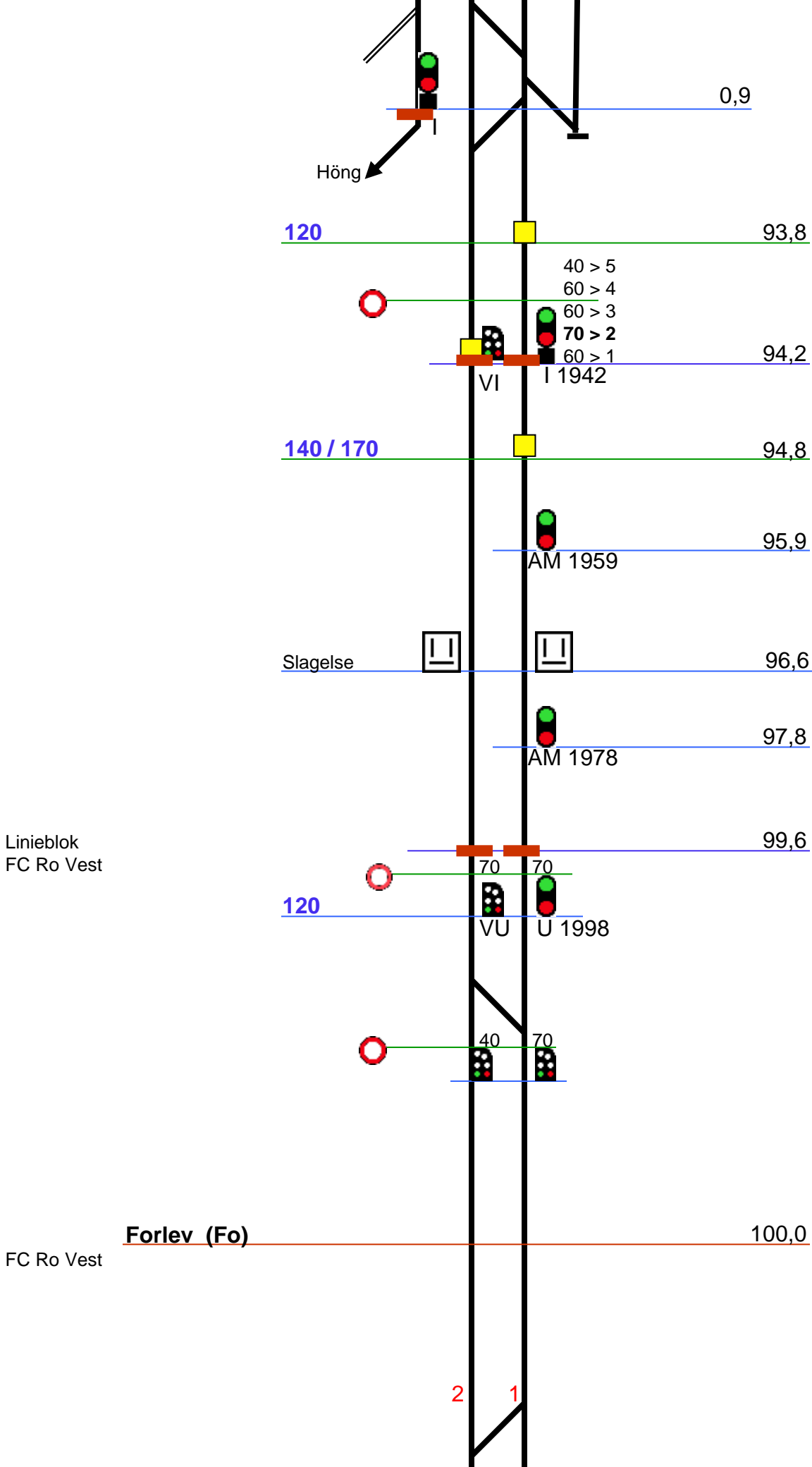

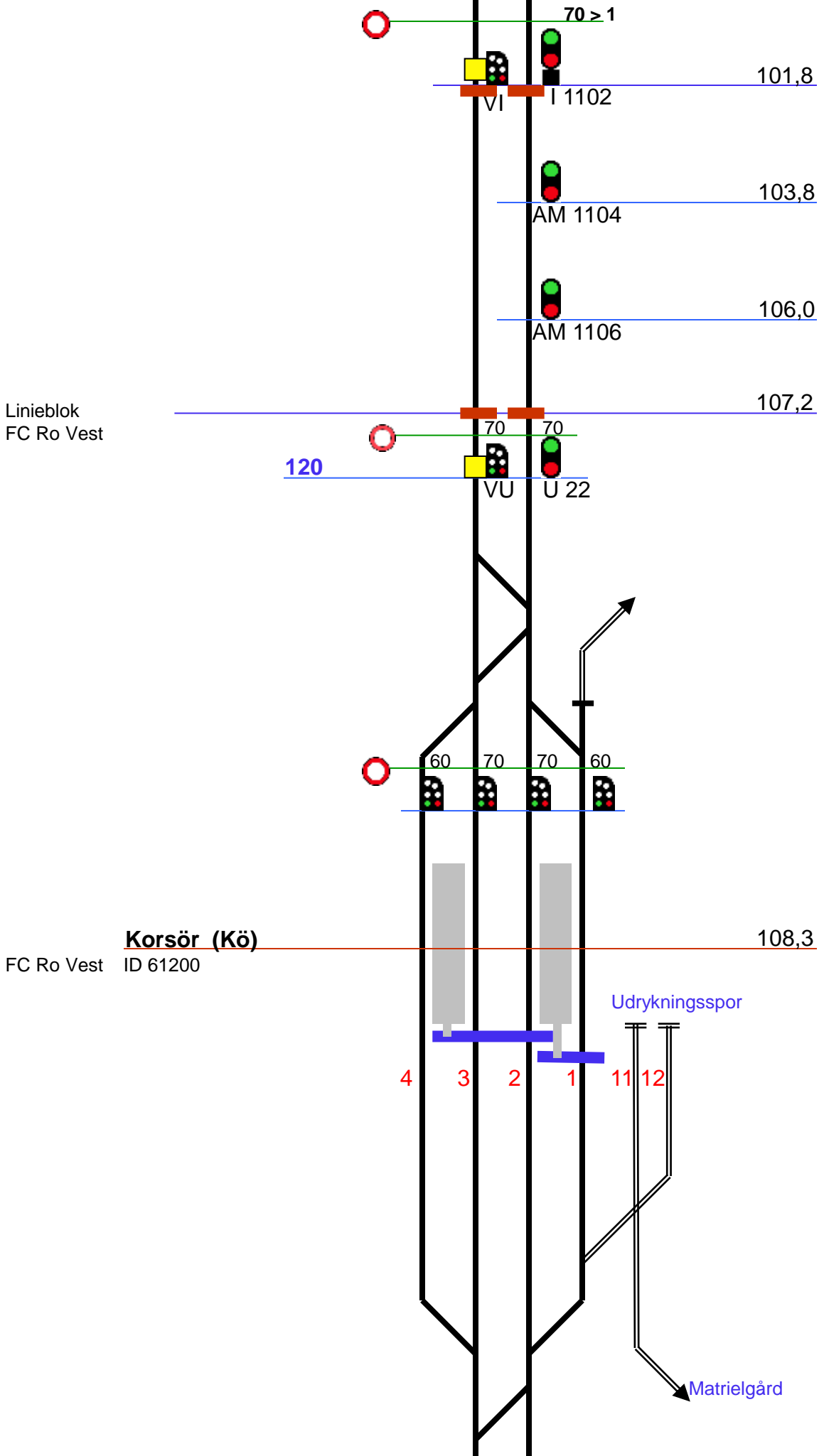

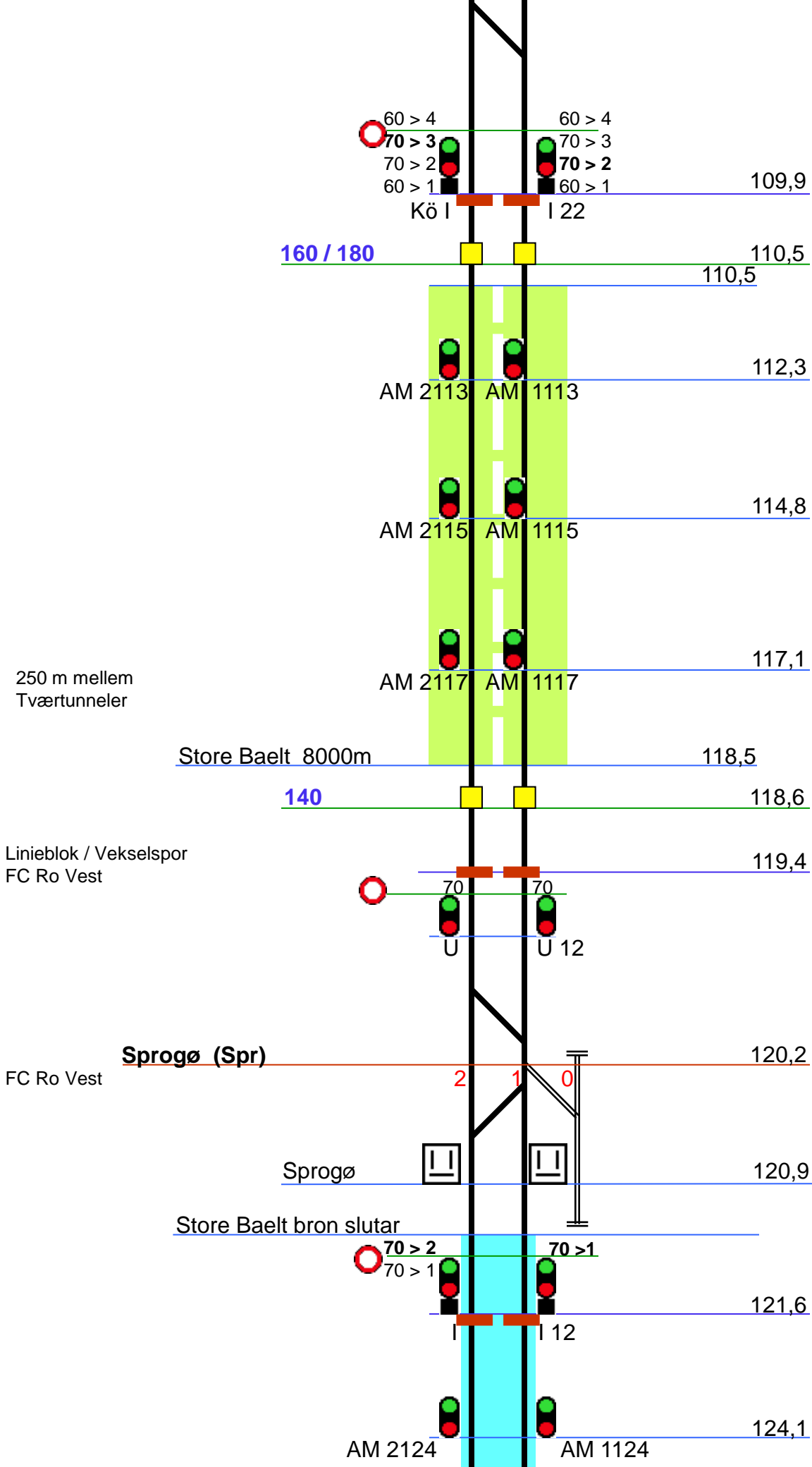

250 m mellem Tværtunneler

Linieblok / Vekselspor FC Ro Vest

FC Ro Vest

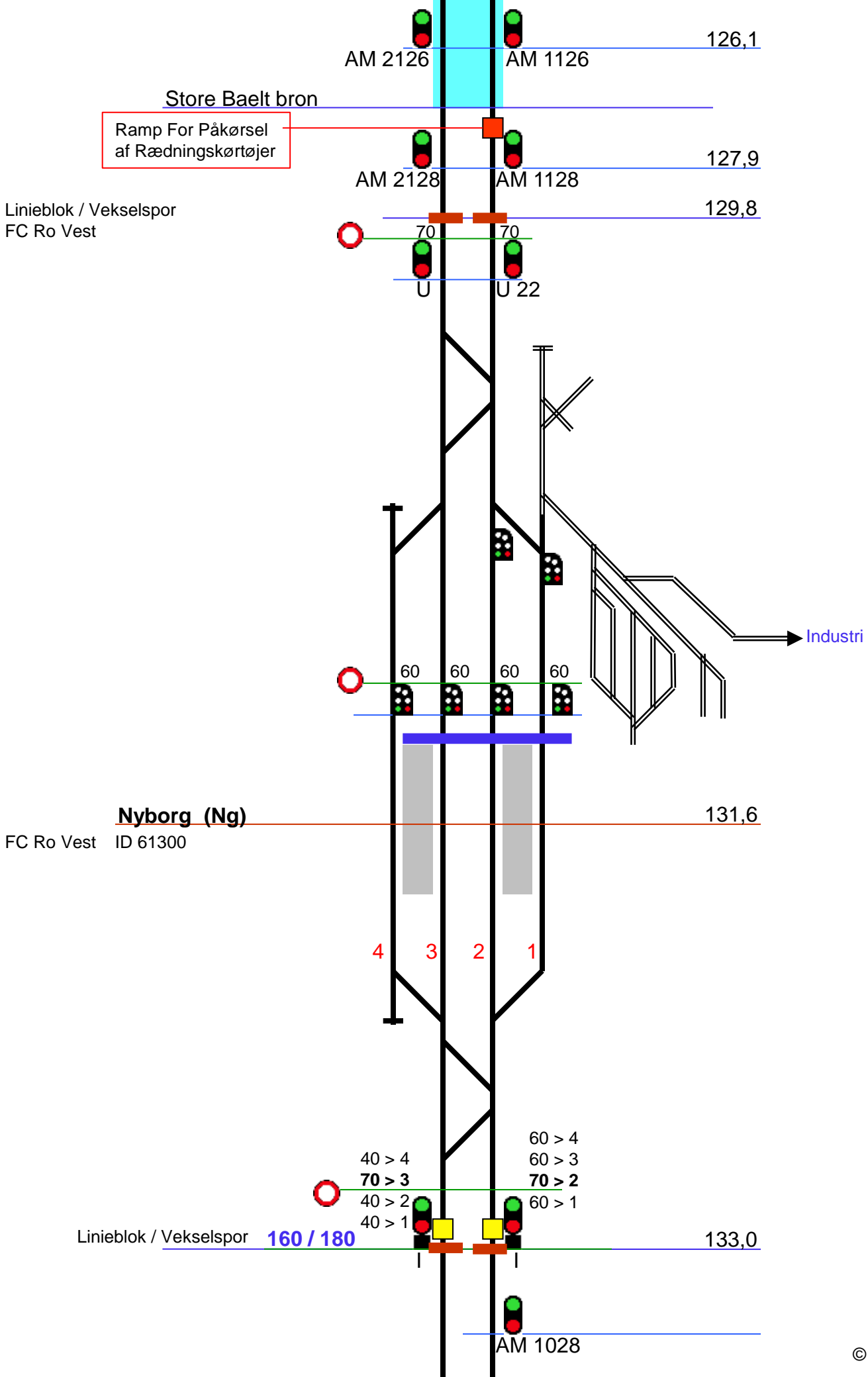

Linieblok
FC Ro Vest

135,6

120



70



VU

70



U 1045

Hjulby (Ju)

136,6

FC Ro Vest

1

2



70 > 2



VI



I 1059

137,2

139,2



AM 1079

Linieblok
FC Ro Vest

141,0

120



70



VU

70



U 1189



70



50



Ullerslev (Uv)

141,5

FC Ro Vest

1

2

3

Linieblok
FC Ro Øst

FC Ro Vest

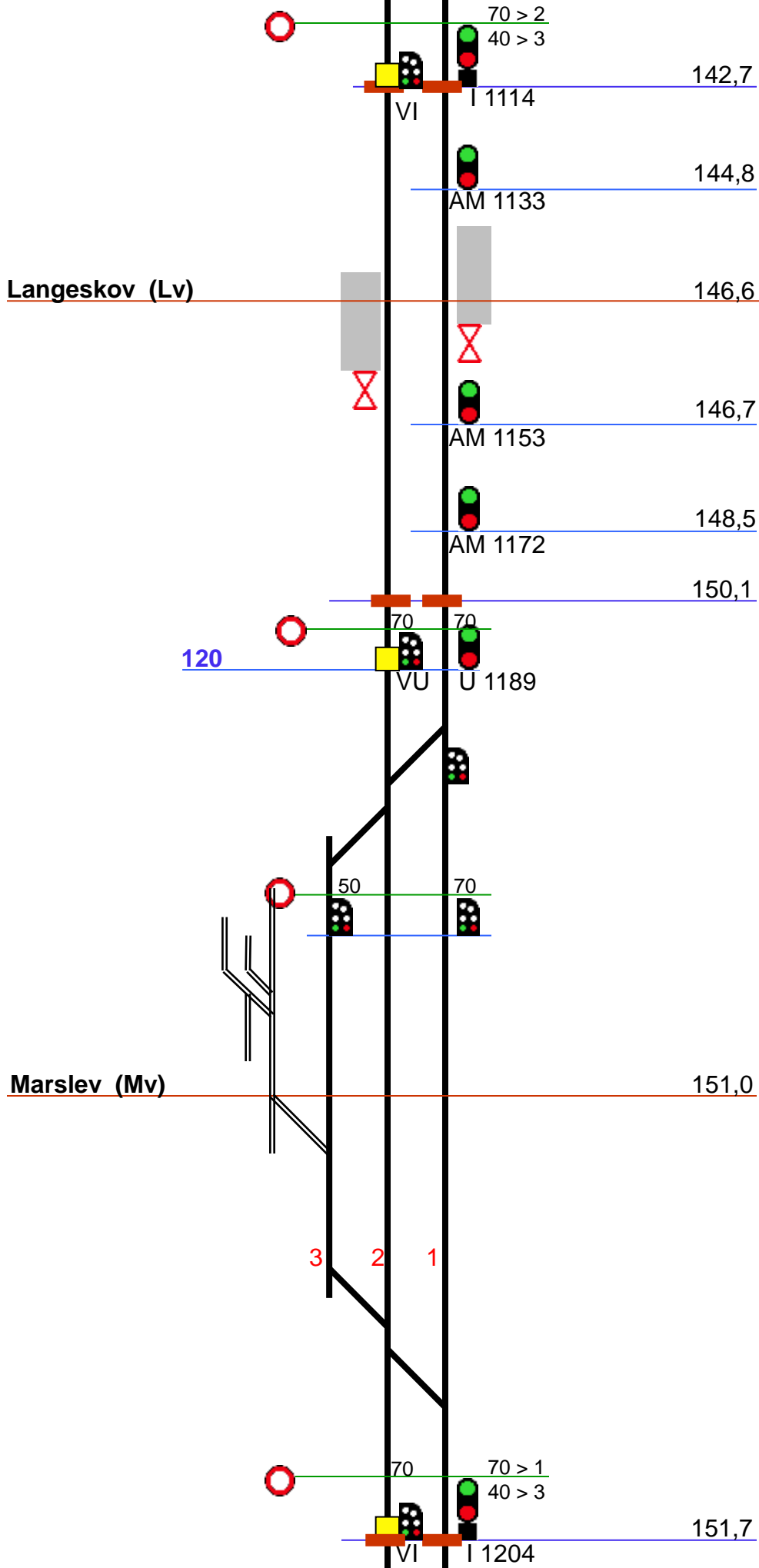

Marslev



153,1

153,7



AM 1224

155,7



AM 1244

157,7



AM 1264

Kaertemindesporet

160 / 180

159,6

Linieblok
FC Ro Vest



70

70

120



VU



U

1284

70

40

60

40



40

Odense (Od)

160,3

Overgangsstation
ID 66800

8

7

6

5

4

3

2

1

21

22

23

24

25

26

27

28

Jernbanemuseum

21 22 23 24 25 26 27 28

8 7 6 5 4 3 2 1

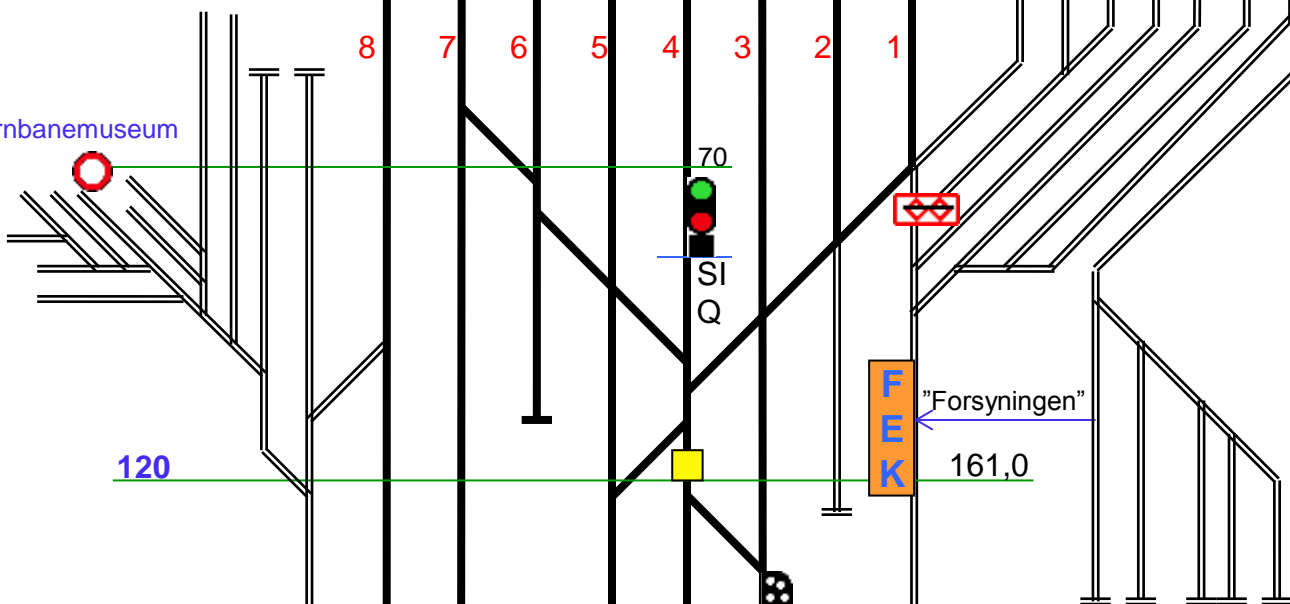

40 > 7
 40 > 6
70 > SI
 40 > 3
 40 > 2

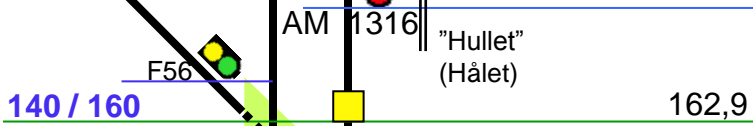
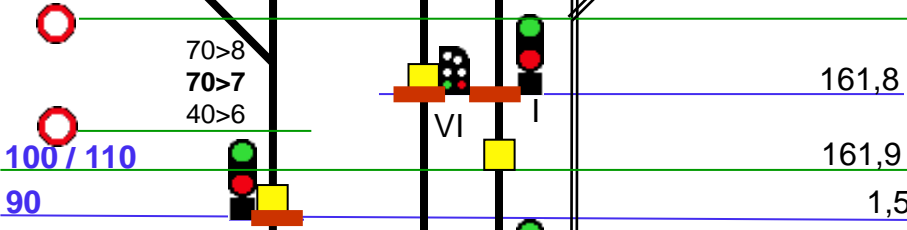

Odense Sugehus (Oss)

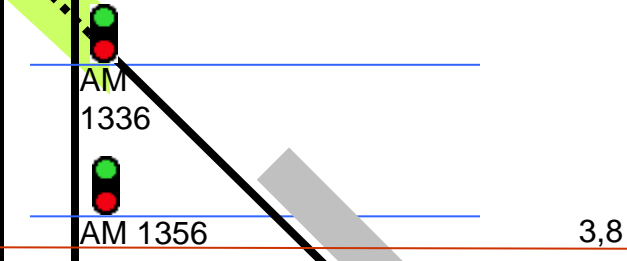

Linieblok
FC Fa

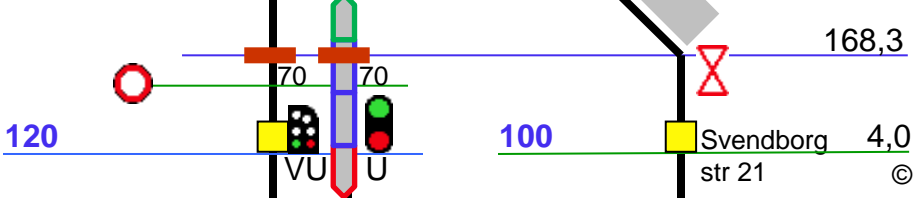

FC Fa

Holmstrup (Hp)

169,1

2 1

60 > 2
70 > 1

169,6

VI

AM 1399

AM 1419

140 / 170

173,9

Linieblok
FC Fa

174,6

120

VU

U

FC Fa

Tommerup (Tp)

175,5

3 2 1



70 > 2
60 > 1

176,3

VI

I



AM 1473

Skalbjerg (Sc)

178,8



140 / 160

179,1



VM 2490



AM 1490

Bred (Bd)

181,1

Linieblok
FC Fa

183,4

Årup (Ap)

184,7

FC Fa

120



70



VU

70



U

70



60



2

1

3

1a

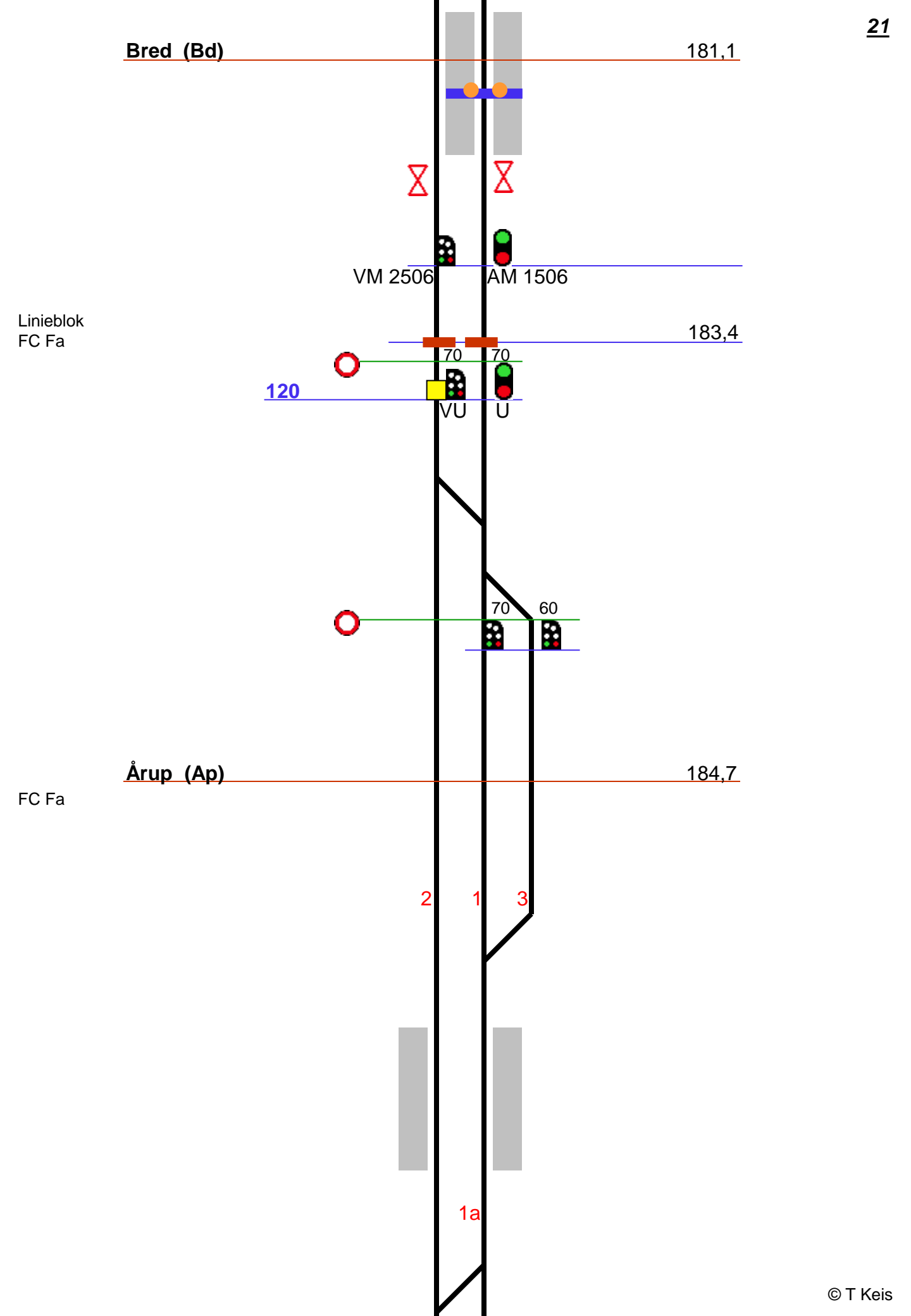

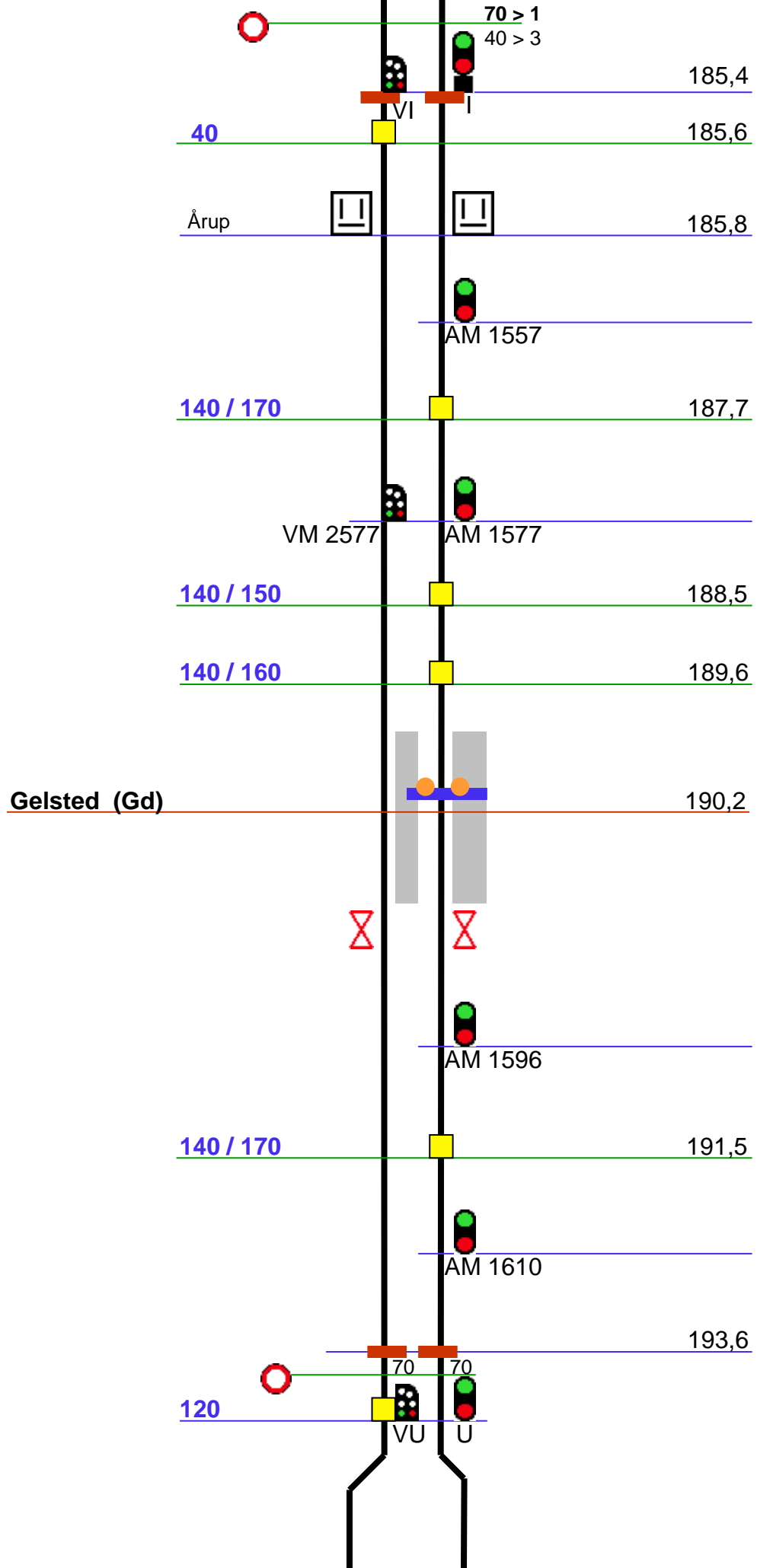

Linieblok
FC Fa

FC Fa

Ejby (Eb)

194,8

3 2 1

195,4

60 > 2
70 > 1

AM 1658

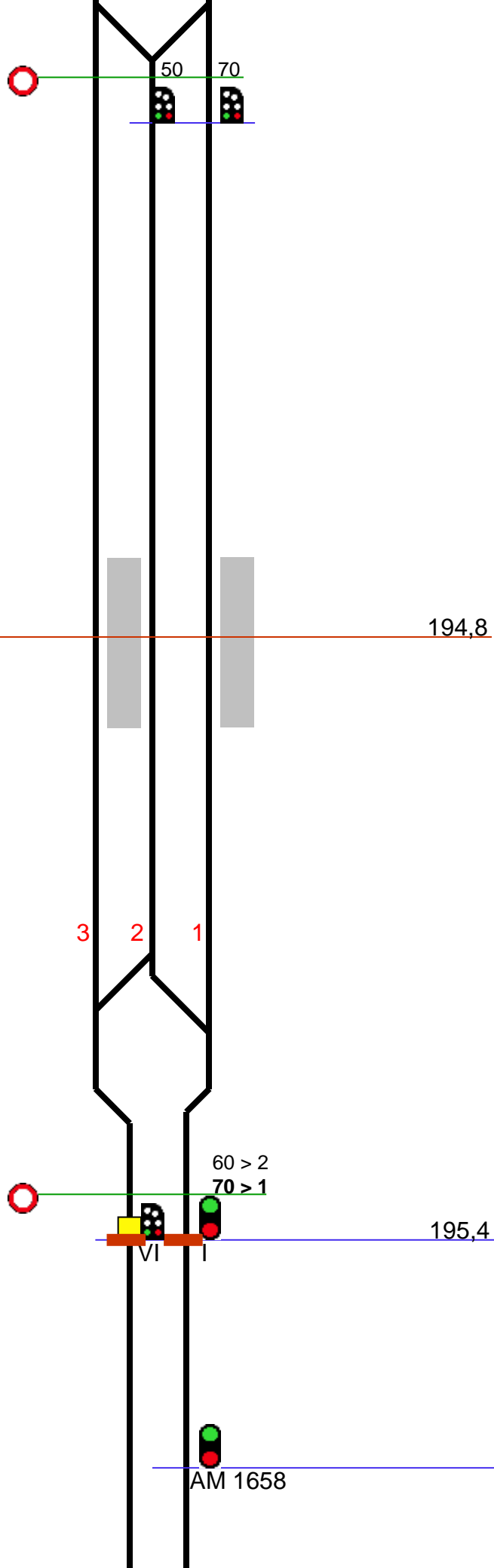

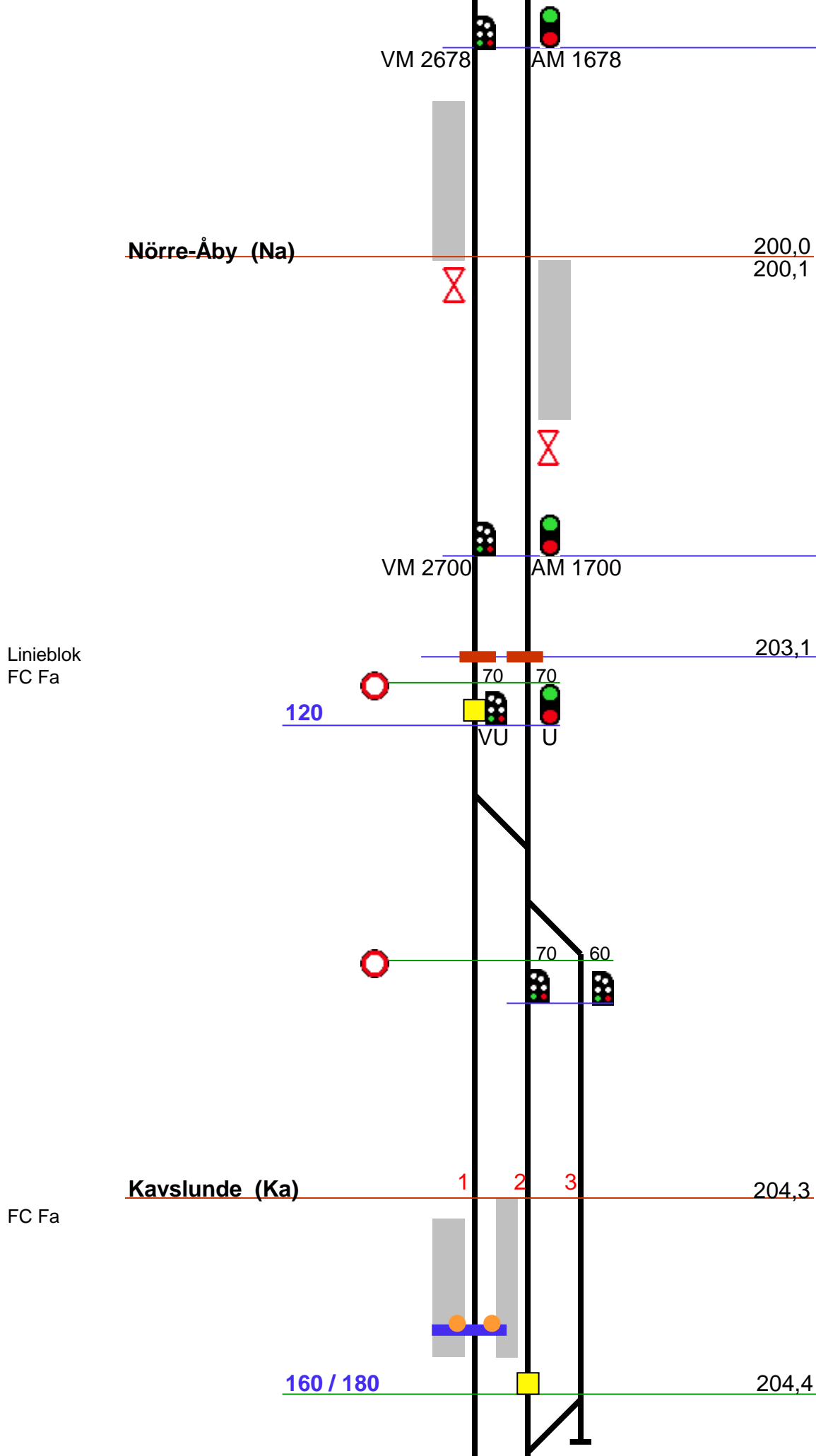

Linieblok
FC Fa

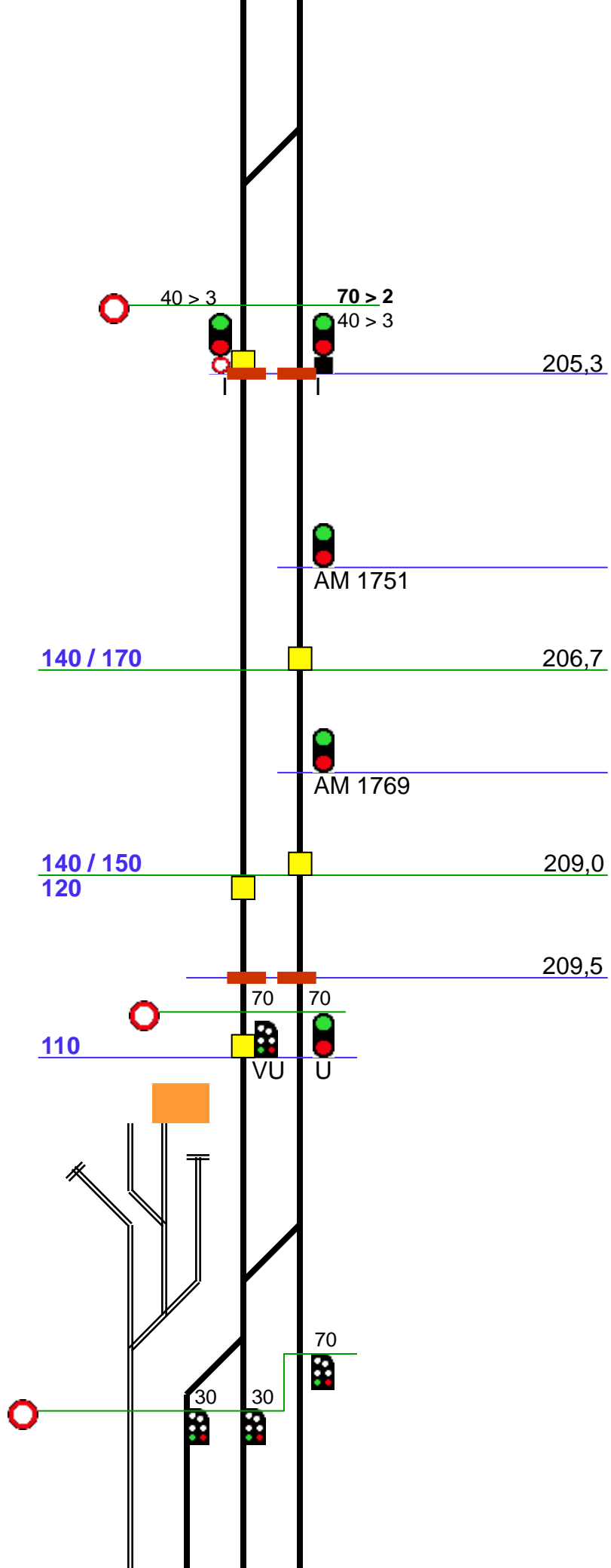

120 / 130

209,8

Middelfart (Md)

ID 67900

210,4

FC Fa

110 / 130

210,6

1

3

4



40 > 1
40 > 2



40 > 1
40 > 3
70 > 4



211,2

Lille Baelt bron slutar

Lille Baelt bron



AM 1820

120 / 130

213,2

Linieblok
FC Fa

214,5

120

70

70

VU

U

120

215,9

2

1

Snoghøj (Sno)

216,3

FC Fa

70 > 2
40 > 1

70 > 2
40 > 2

70 > 1

216,6

90 / 100

70 > 1

216,5

216,7

Fredericia

AM 2219

AM 1219

hsp 2

1

Linieblok
FC Fa

Linieblok / Vekselspor
FC Fa

220,1

140

70

70

VU

U

70

70

U

U

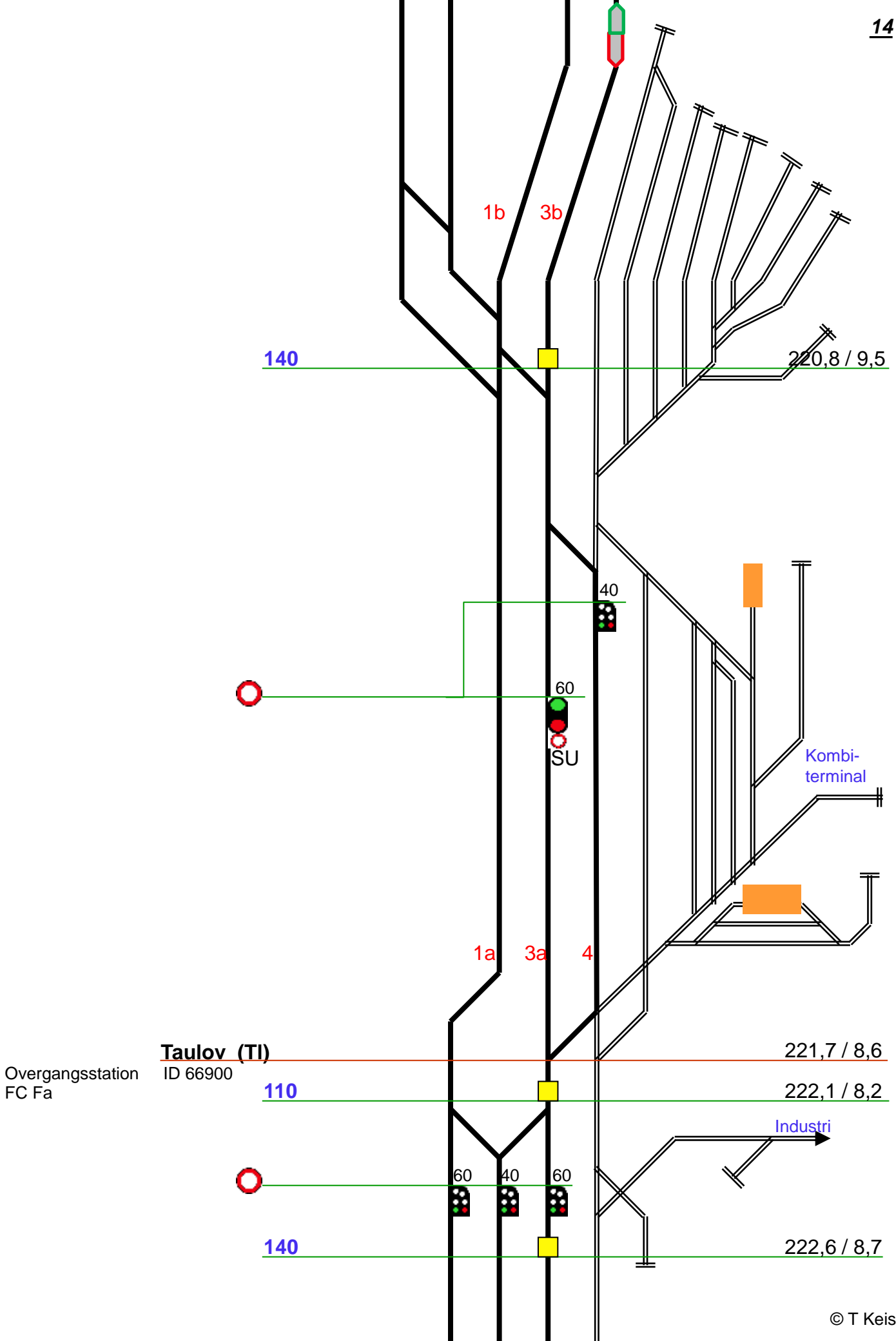

Taulov (TI)

ID 66900

Overgangsstation
FC Fa

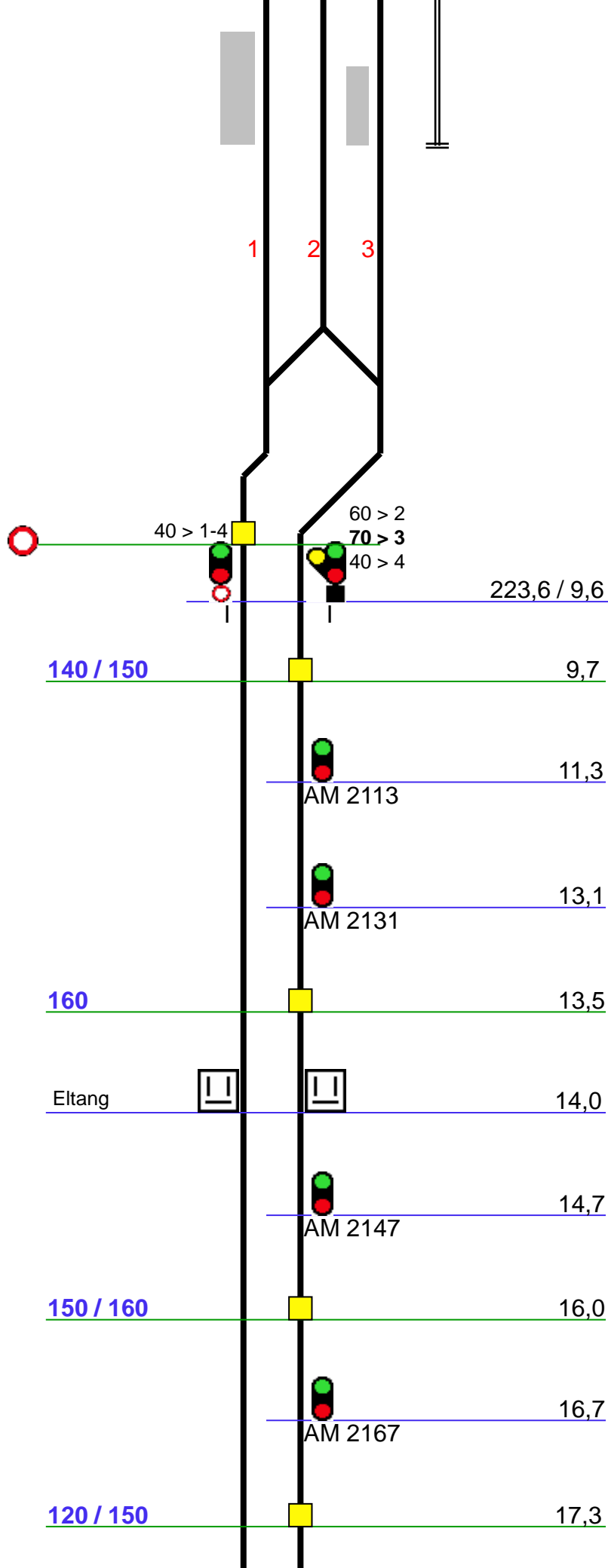

Linieblok
FC Fa

120 / 140 18,3

18,6

120 / 130
120 18,8

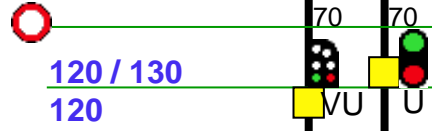

70 40

Kolding (Kd)
FC Fa
ID 62027

19,9

120 20,1

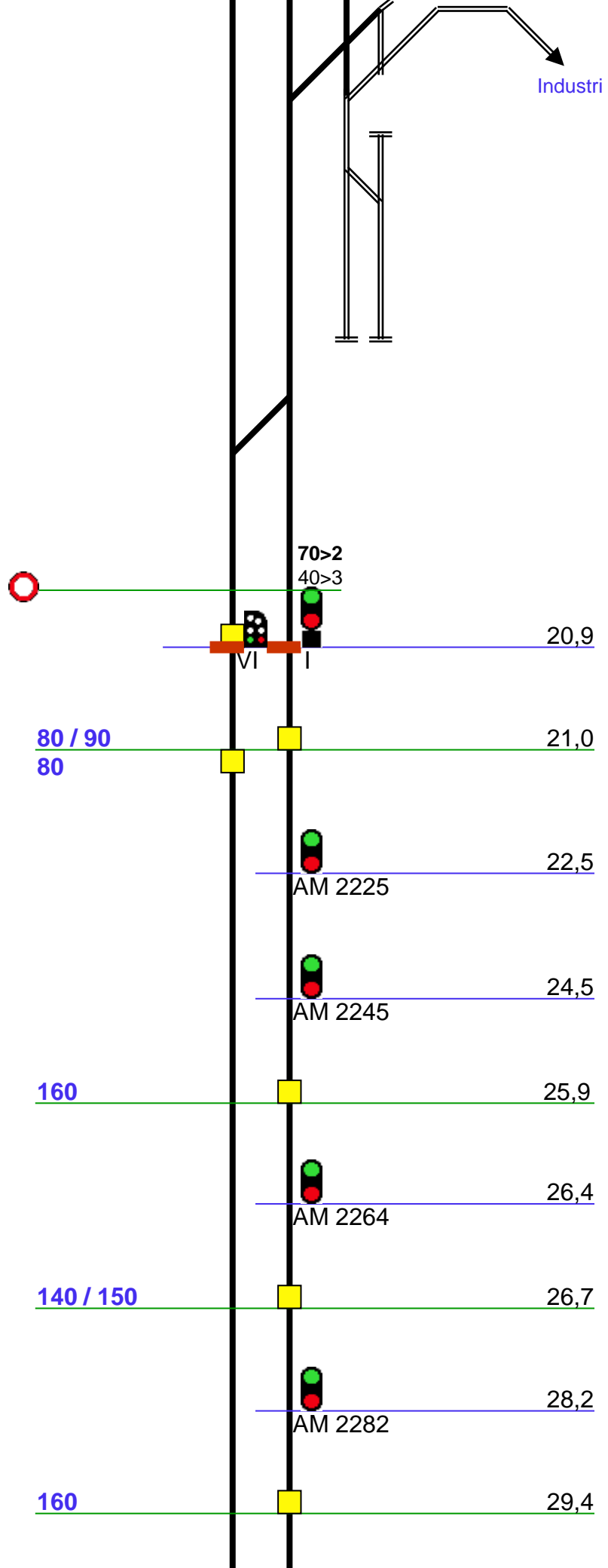

Linieblok
FC Fa

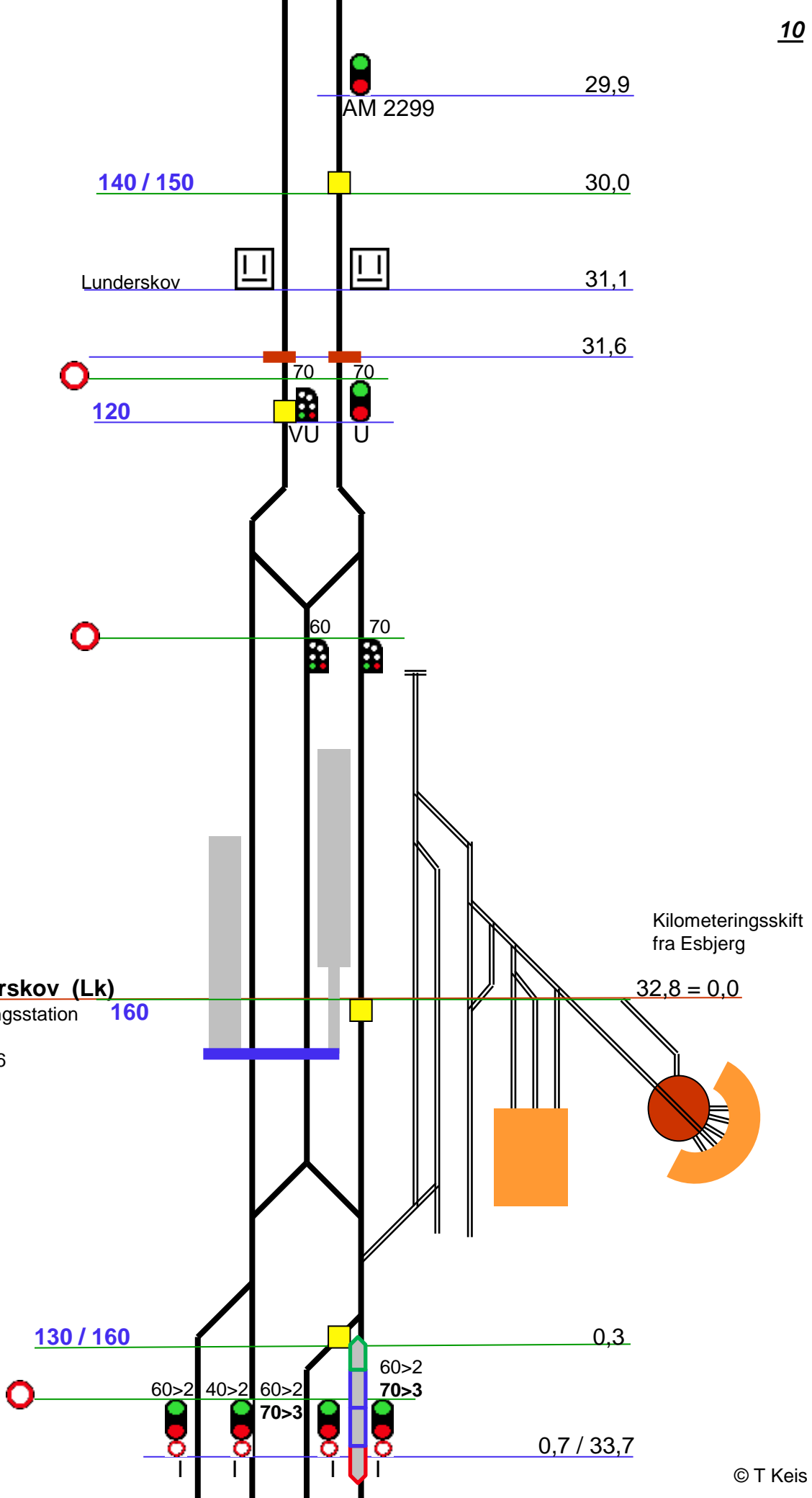

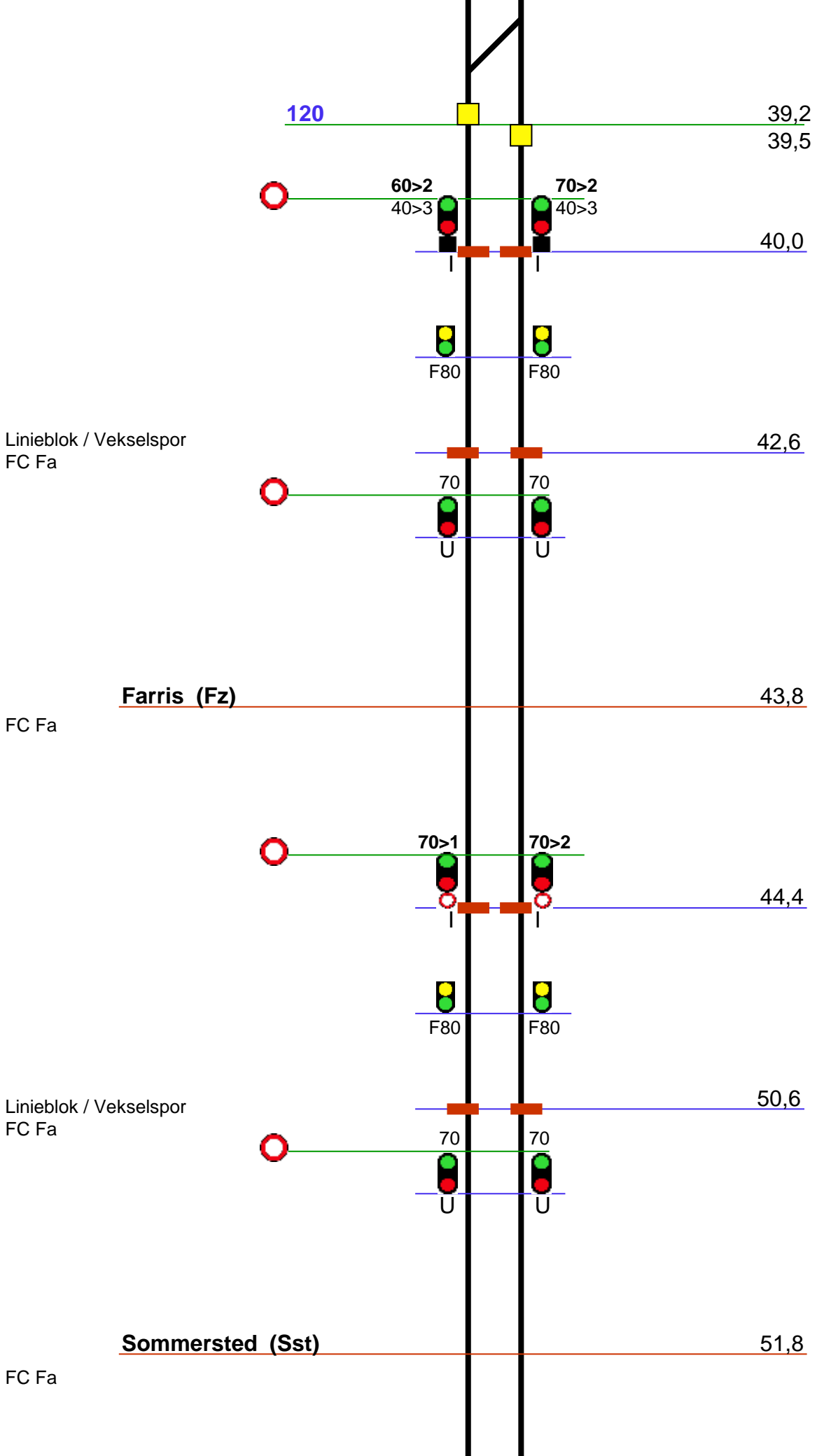

Linieblok / Vekselspor
FC Fa

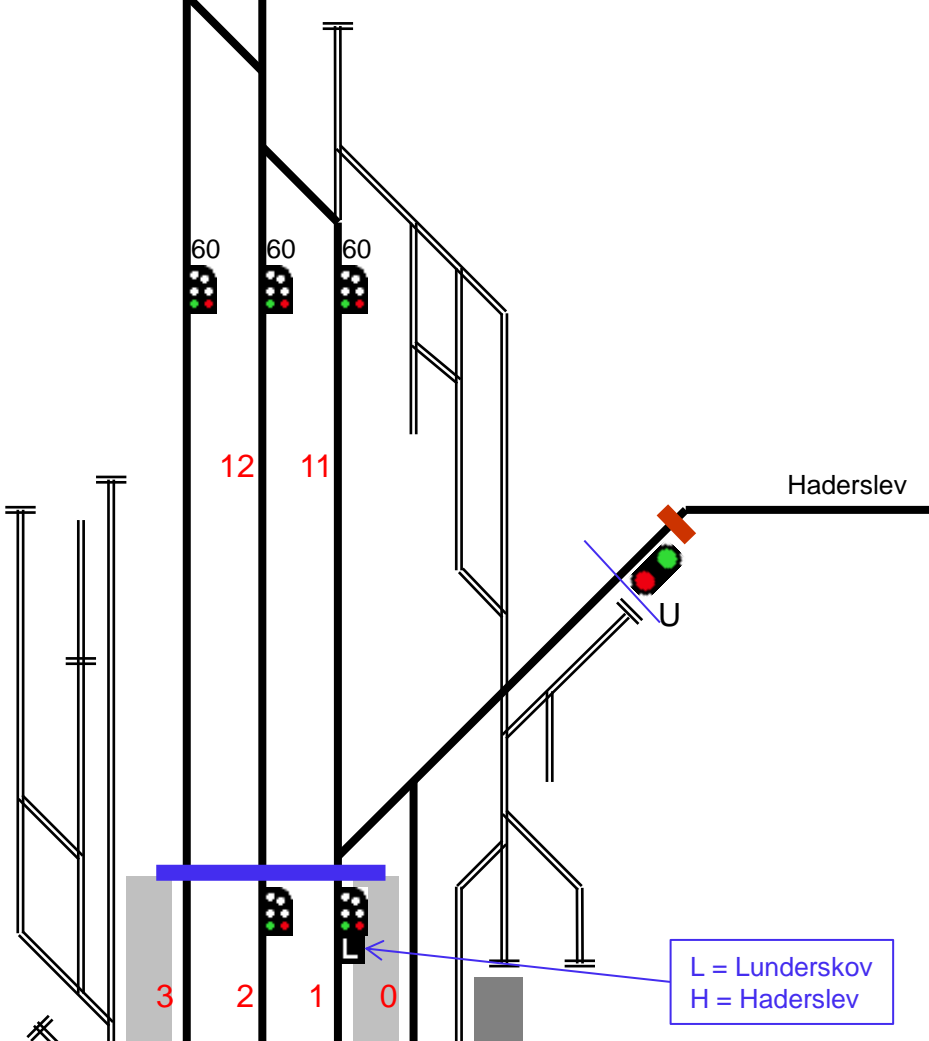
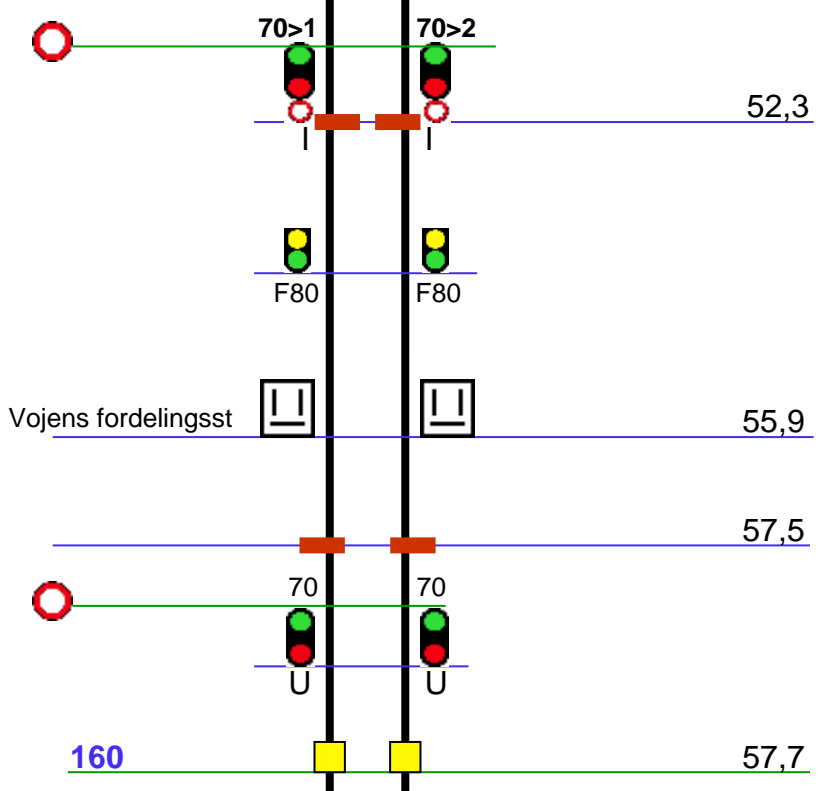

Vojens (Oj)
FC Fa
ID 62066

L = Lunderskov
H = Haderslev

160 / 180

78,2
78,2
78,3

Ved berejning af udsigtslængde
jf SR bilag 3 anvendes
tophastighed 200 km/h

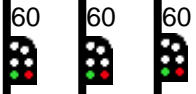
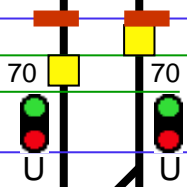

Røde kro (Rg)

79,6

FC Fa

3 2 1

XX,x

Ovk

XX,x

120

80,5



70>1
60>2
60>1



70>2
60>1



120

80,7

Ovk

XX,x

Aabenraa

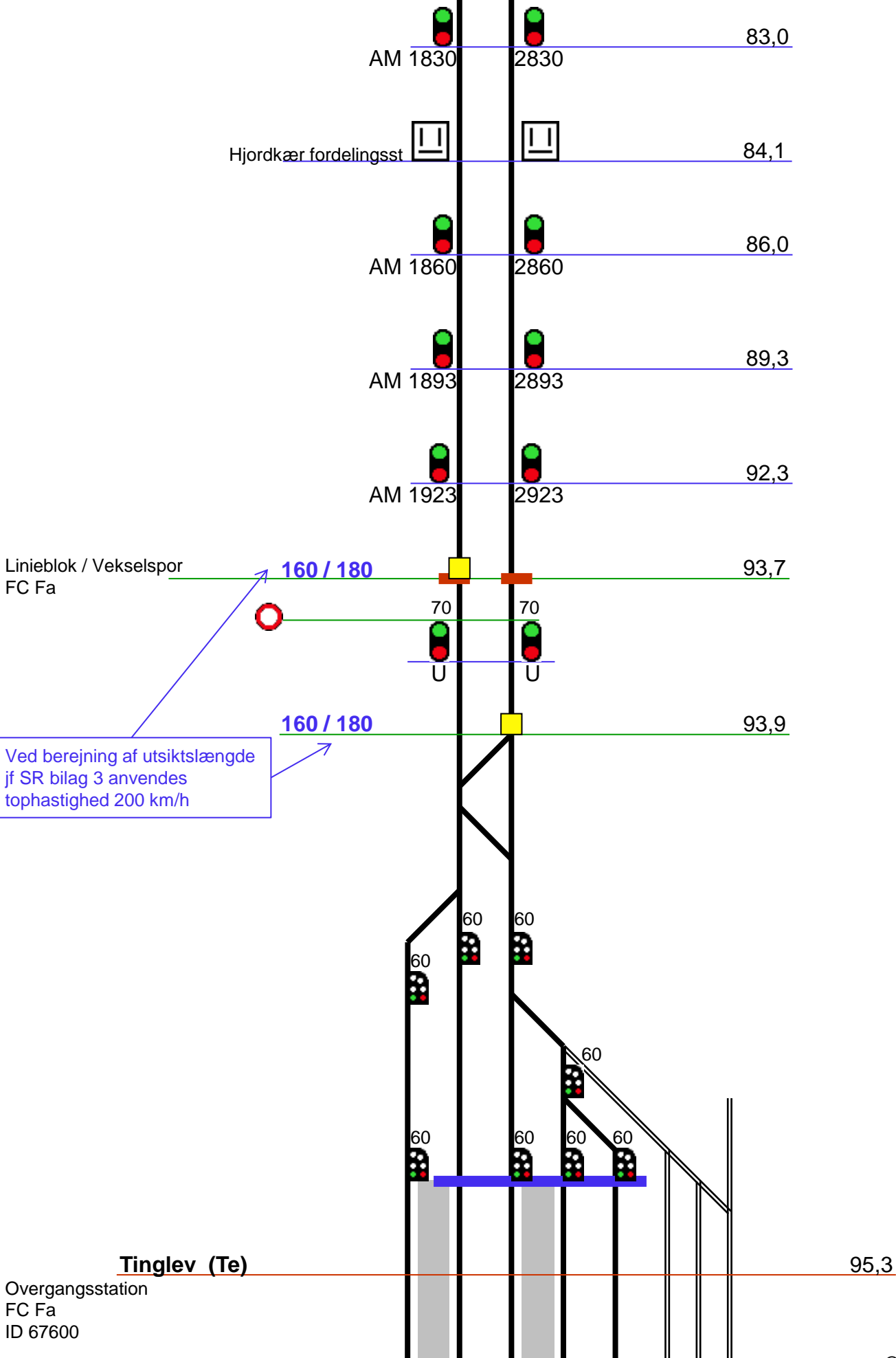

Industri

Linieblok
FC Fa

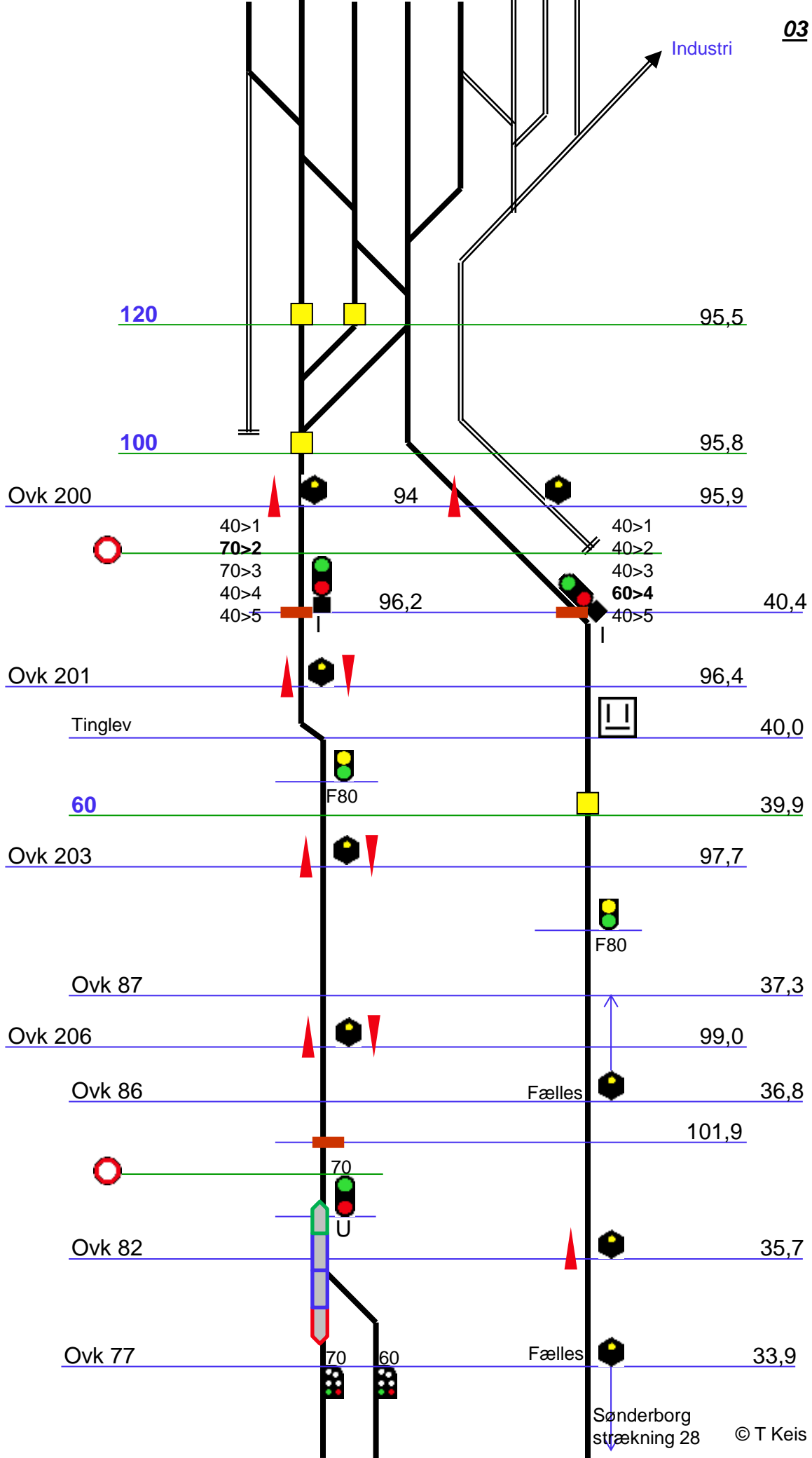

Sønderborg
strækning 28

FC Fa

2 1

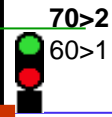

103,6



F80

Ovk 216



105,2

Linieblok
FC Fa

108,4



120

108,9

