

Svågertorp (Stp)

288.228

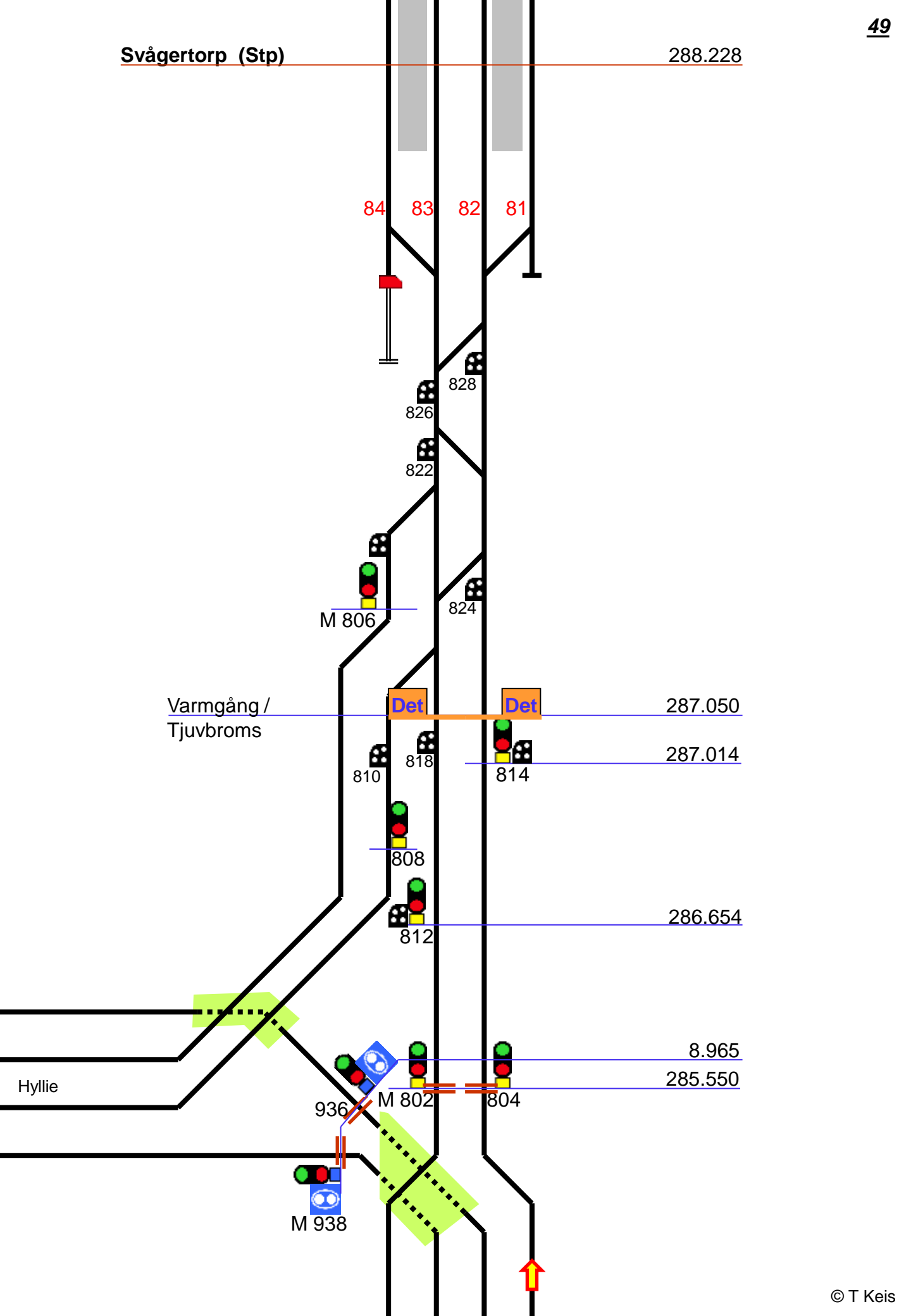

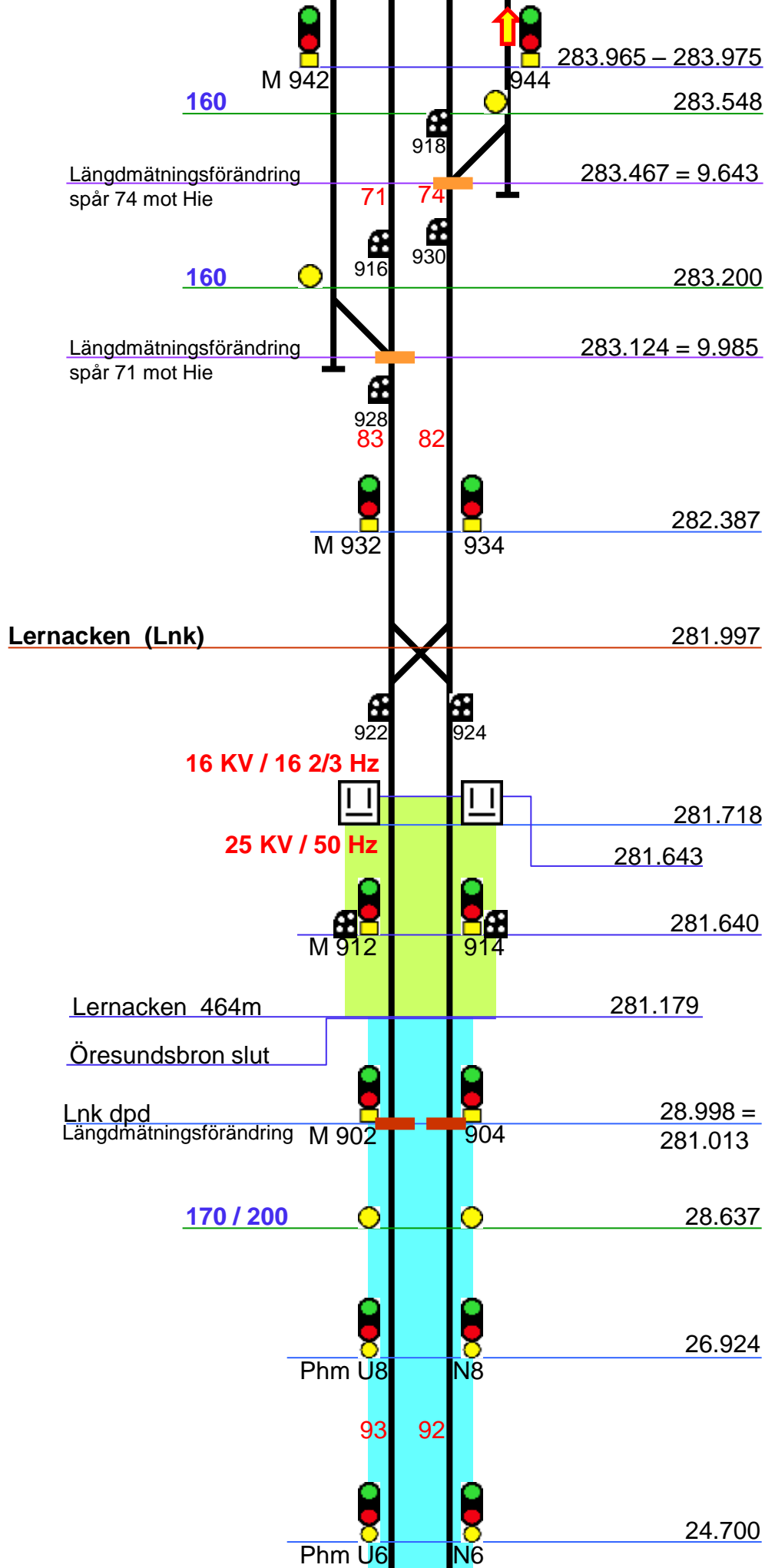

Territorialgräns

Se



23.627

Dk



22.476

Phm U4

N4

Øresundsbroen 7872m

21.292

20.304

Phm U42

N72

20.204

Peberholm (Phm)

19.139

34

64

200

18.435

Malmö TC



TTJ

SR

SE ATC Börjar

DK ATC Sluter



Phm 22



52

18.235

Systemgrænse

18,2

17.496

17,5

AM 2162

AM 1162

16,2

14,5



70

70

Cph U

Cph U

Linieblok / Vekselspor
FC Kh

Tværgange med 88m mellemrum

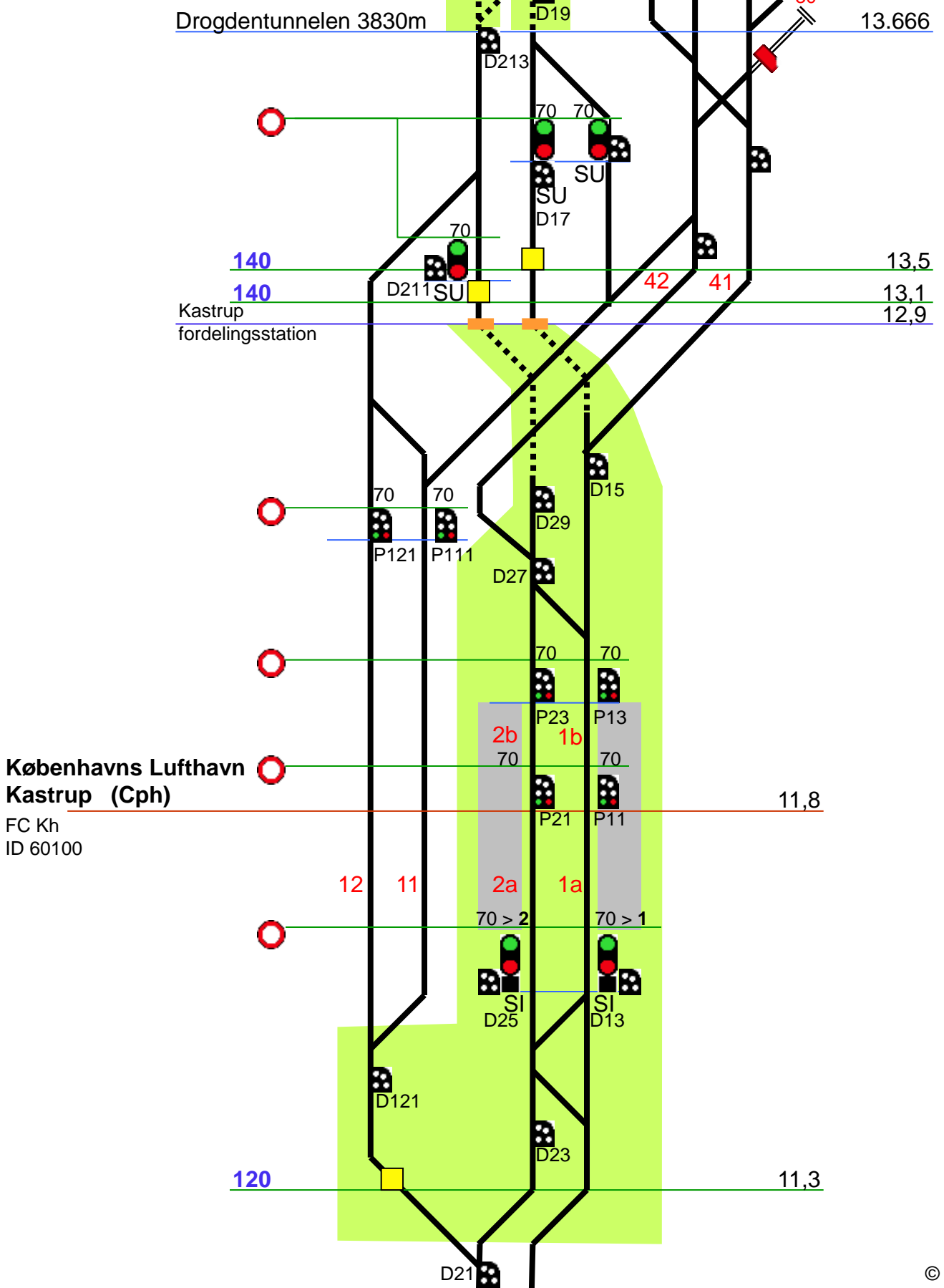

Københavns Lufthavn Kastrup (Cph)

FC Kh
ID 60100

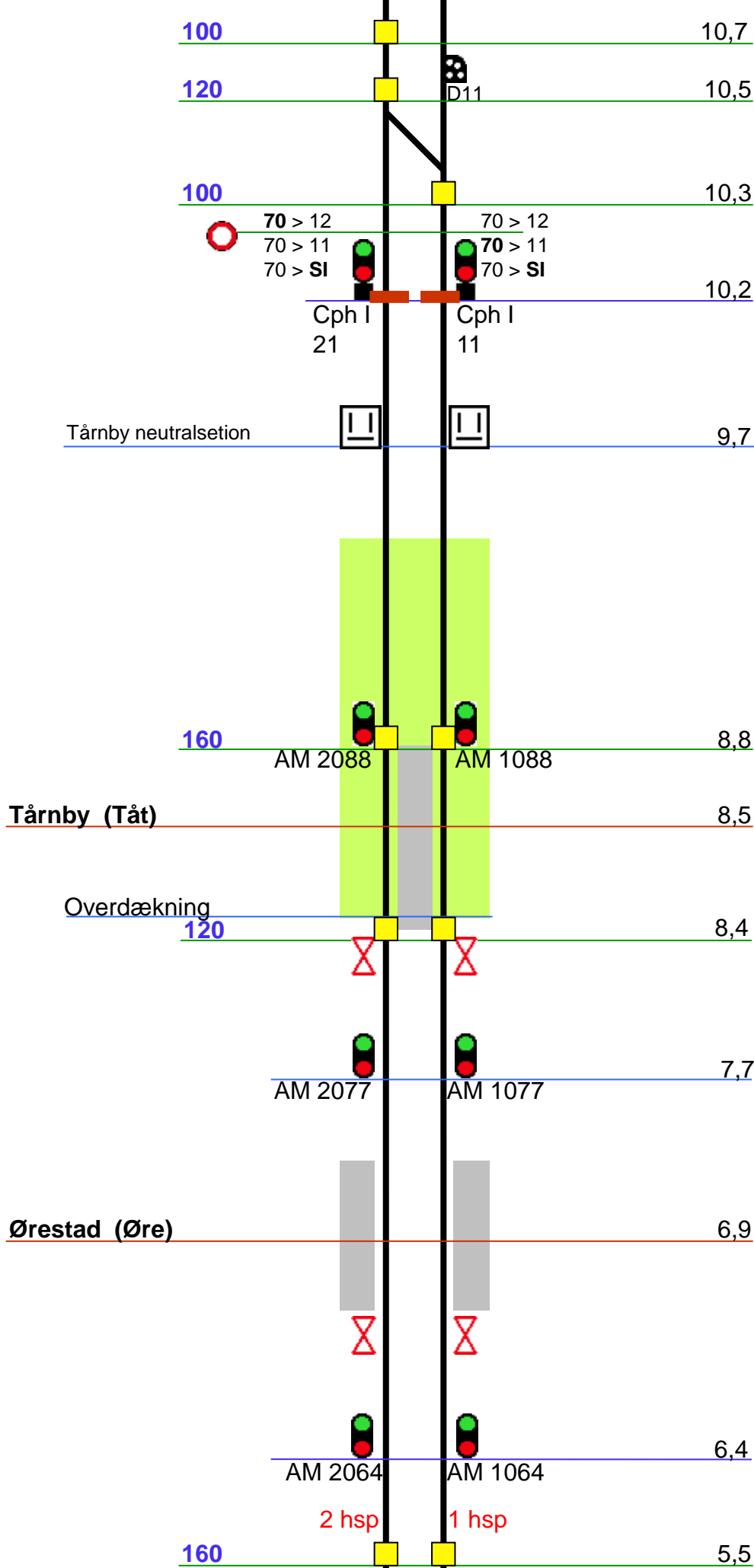

Lastprofil / Tjuvbroms
/ Varmgang

Det Det

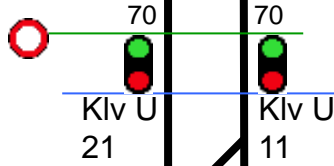

130

4,9

Kalvebod (Klv)

4,8

FC Kh

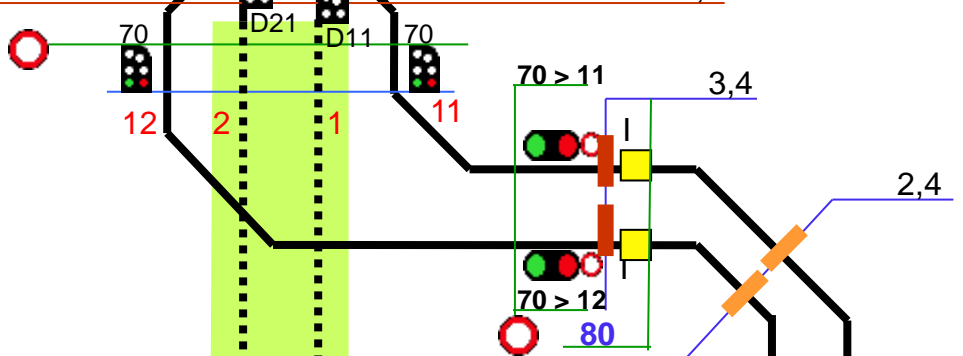

Linieblok / Vekselspor
FC Kh

Vigerslev fordelsstation

Kilometreringssift

130

4,0

130

3,9

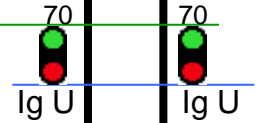

Vigerslev
neutralsektion

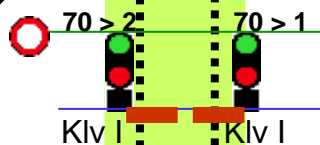

Vigerslev (Ig)

Overgangsstation
FC Kh

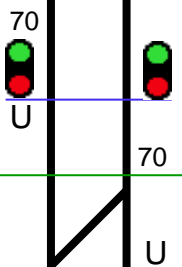

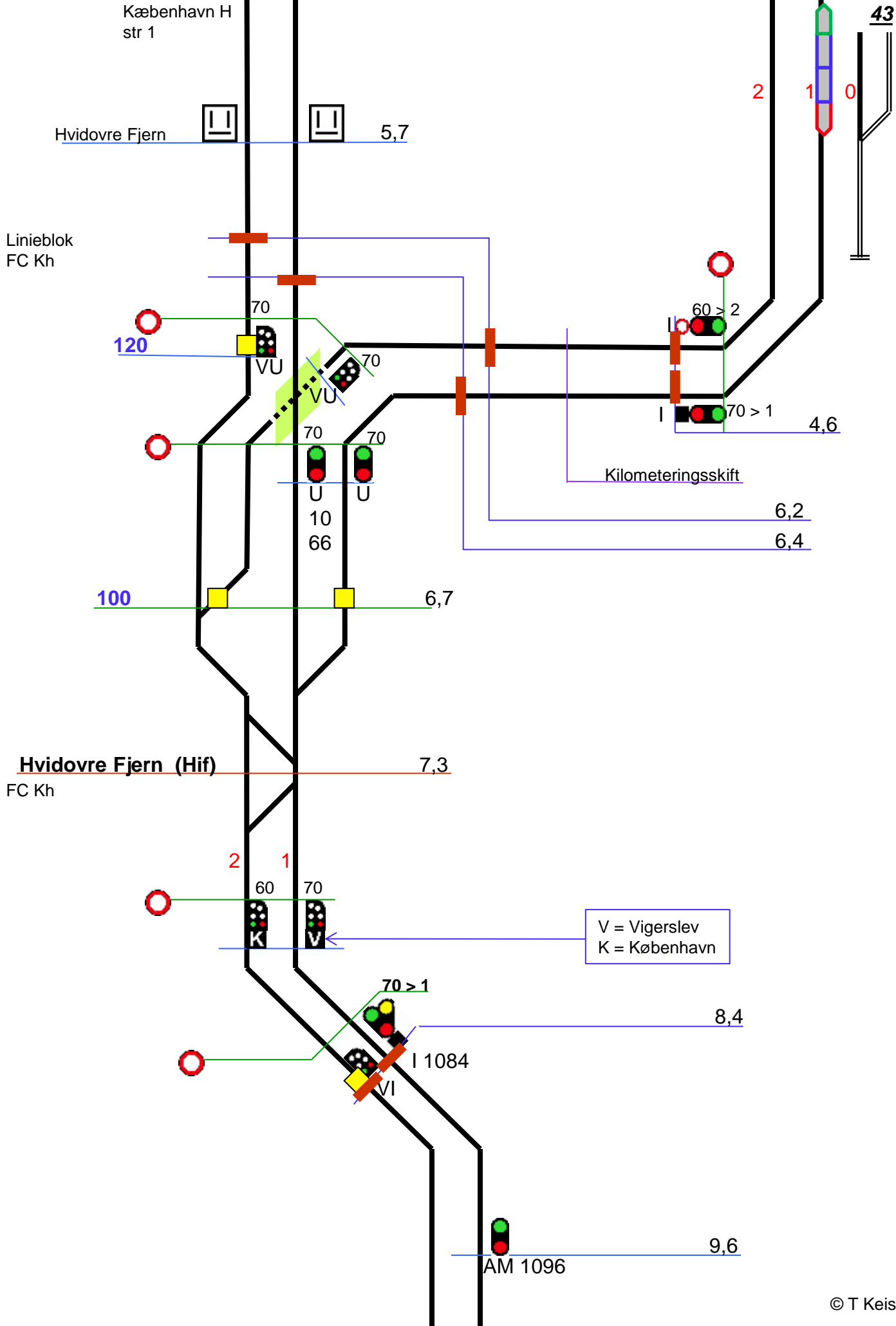

FC Kh
ID 60001

Glostrup (GI)

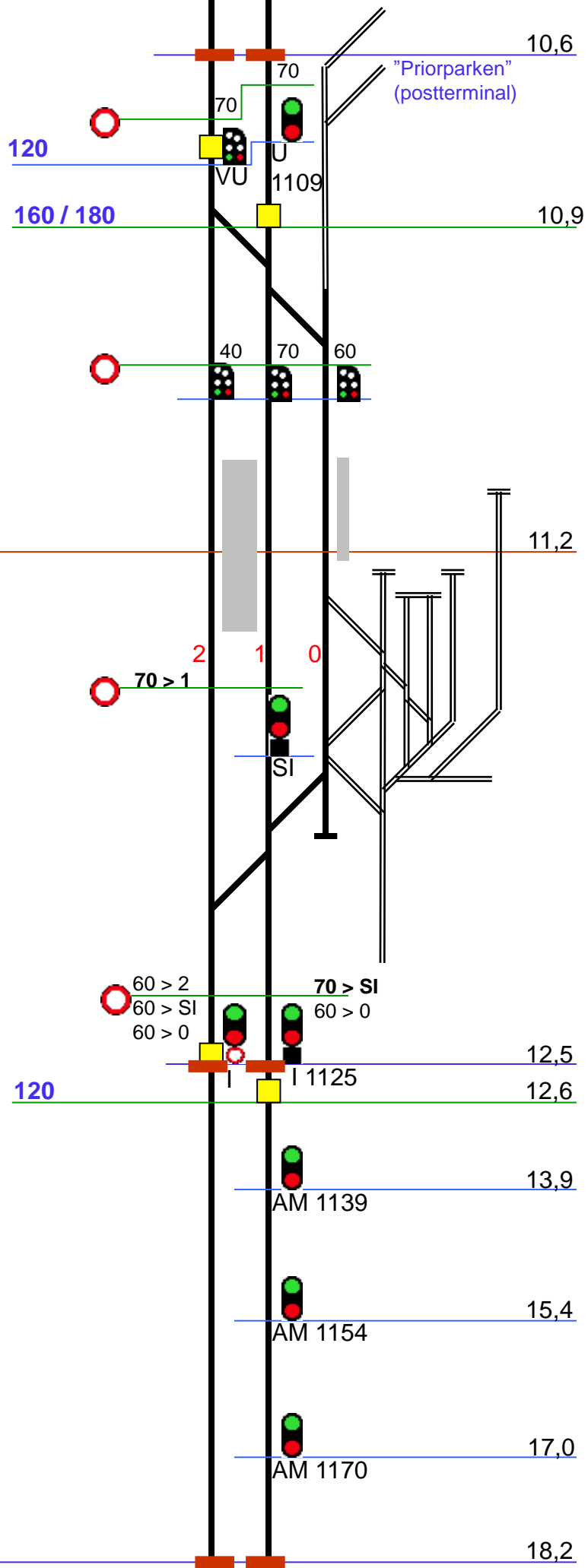

S – Tog
str 8.2
København H

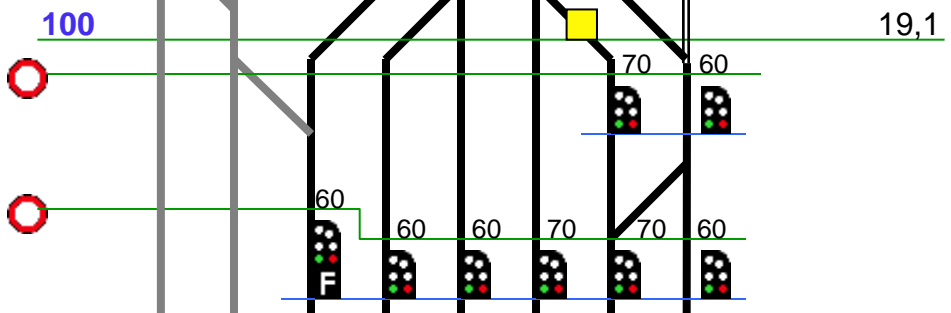
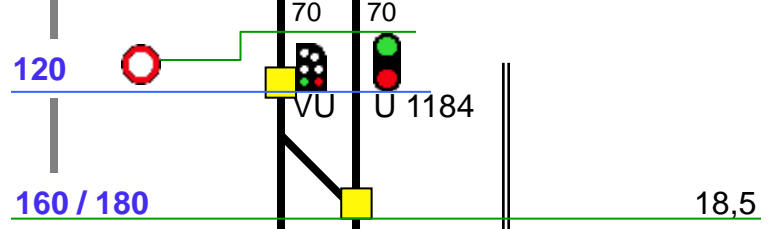

Høje Taastrup (Htå)

Overgangsstation
FC Ro Øst
ID 61001



5 4 3 2 1 0

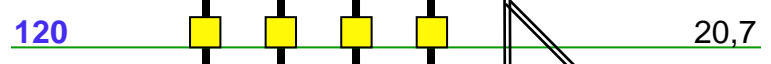

	> 5	4	3	2	1	0
hsp 4	60	70	60	60	60	60
hsp 3	60	60	70	60	60	60
hsp 2	60	60	60	70	60	60
hsp 1	60	60	60	60	70	60

4 3 2 1

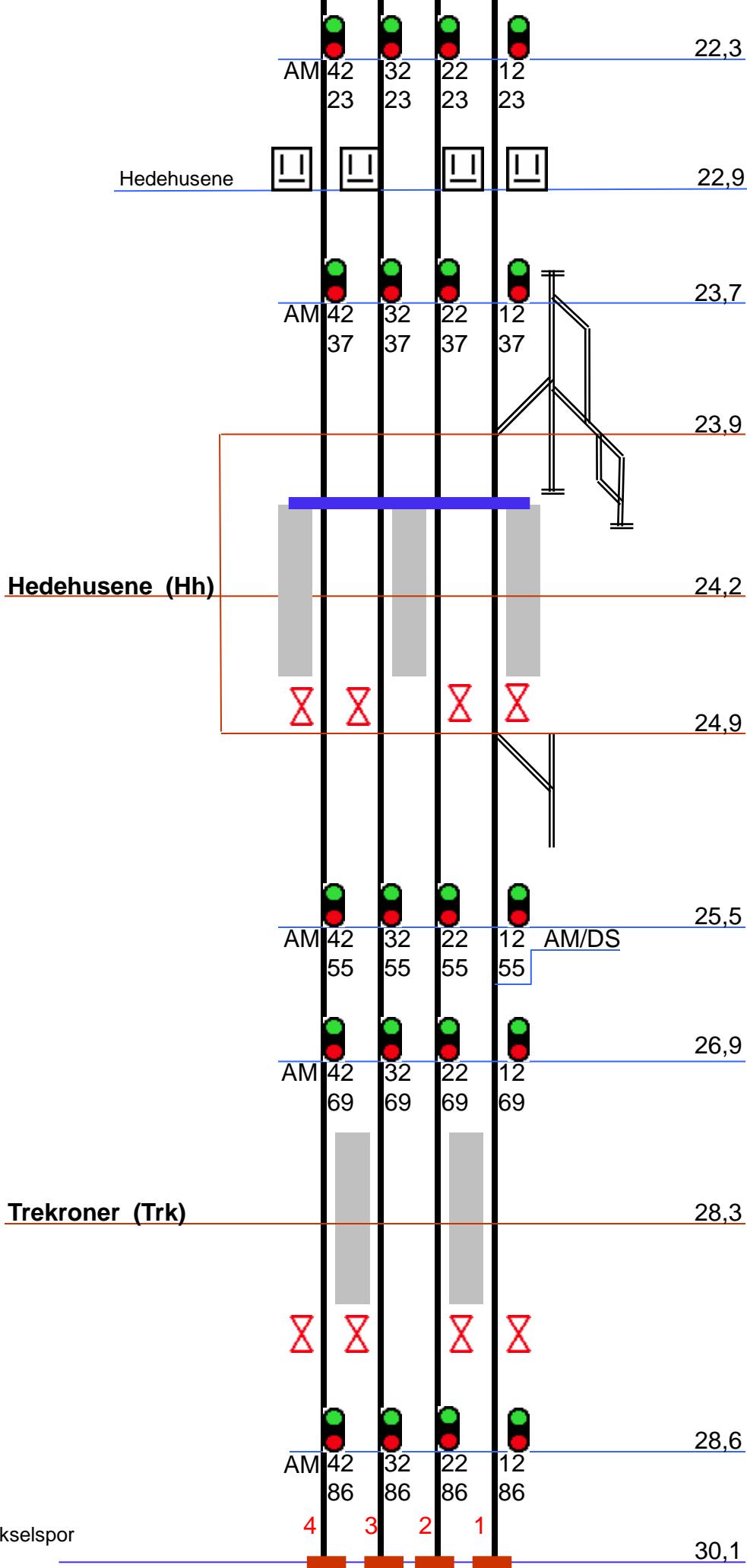

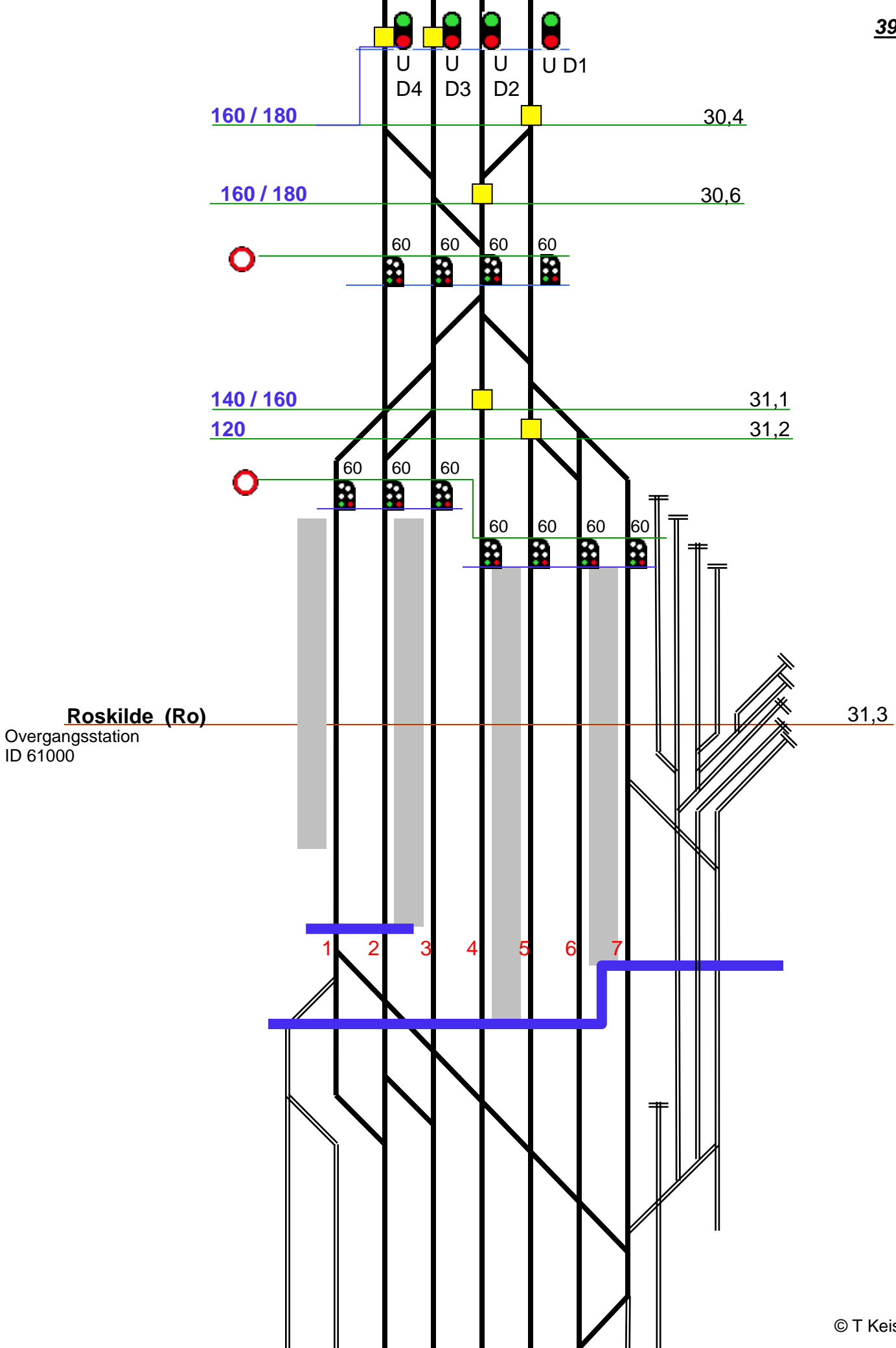

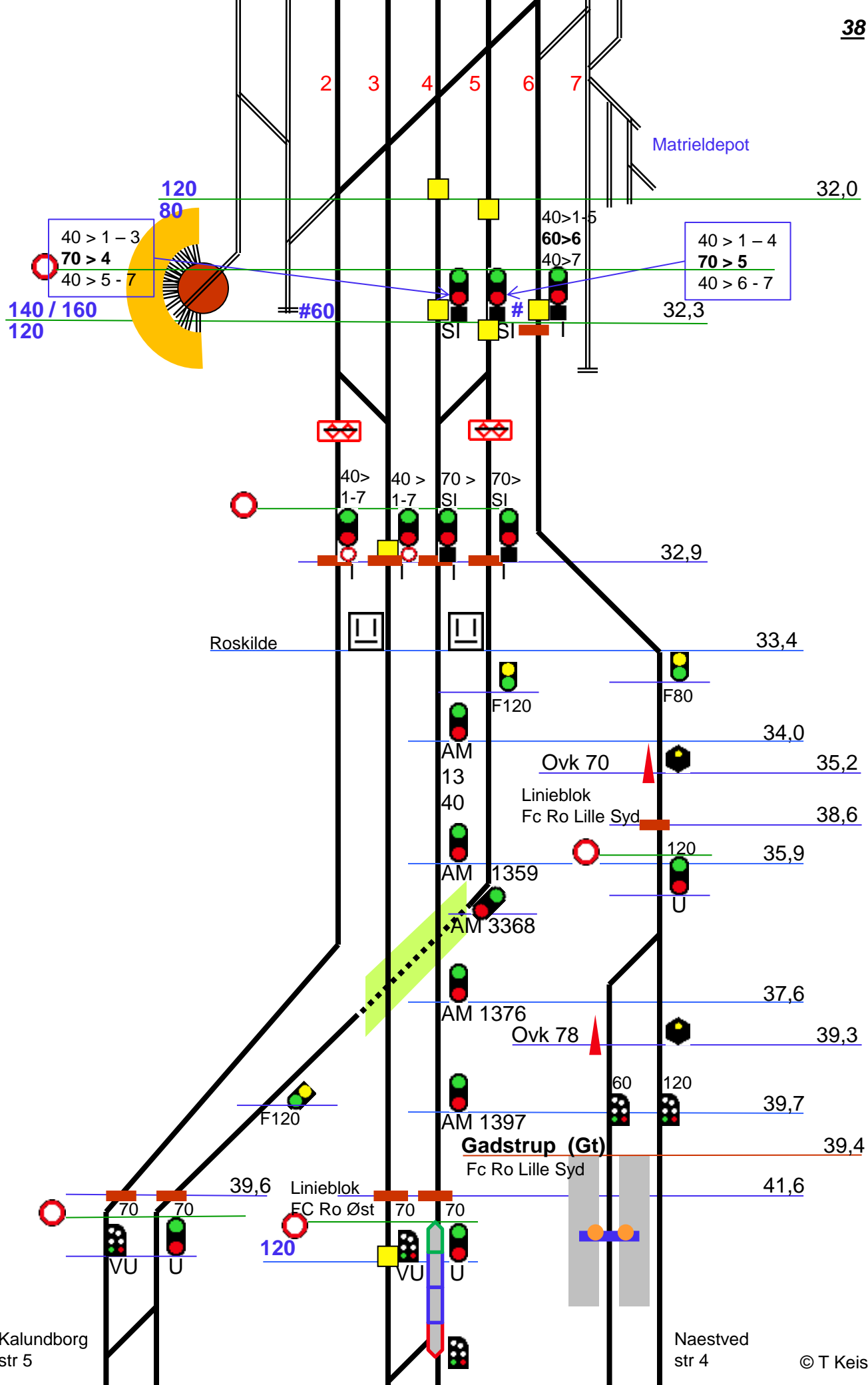

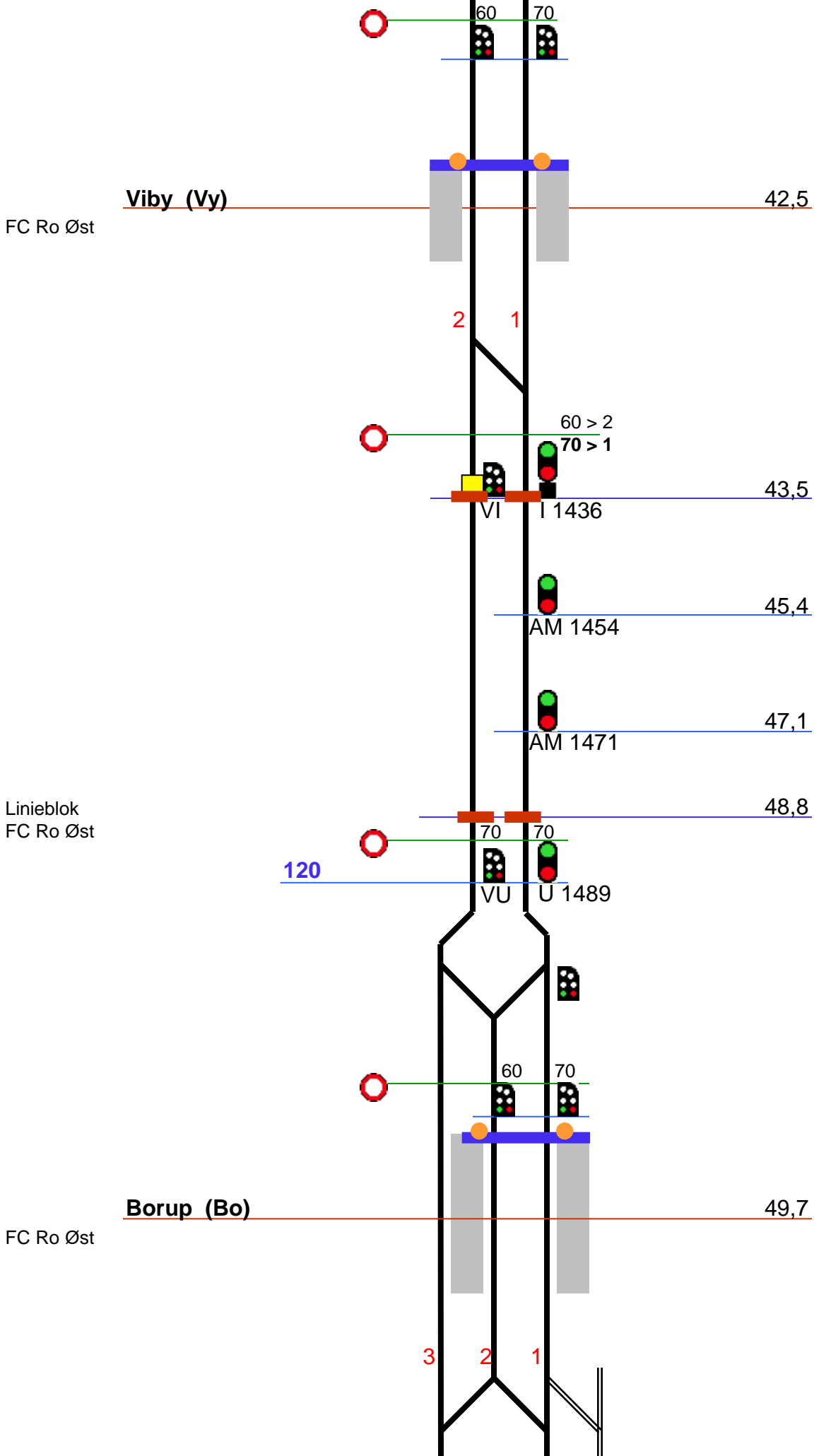

Linieblok
FC Ro Øst

Kværkeby (Ky)

FC Ro Øst

Linieblok
FC Ro Øst

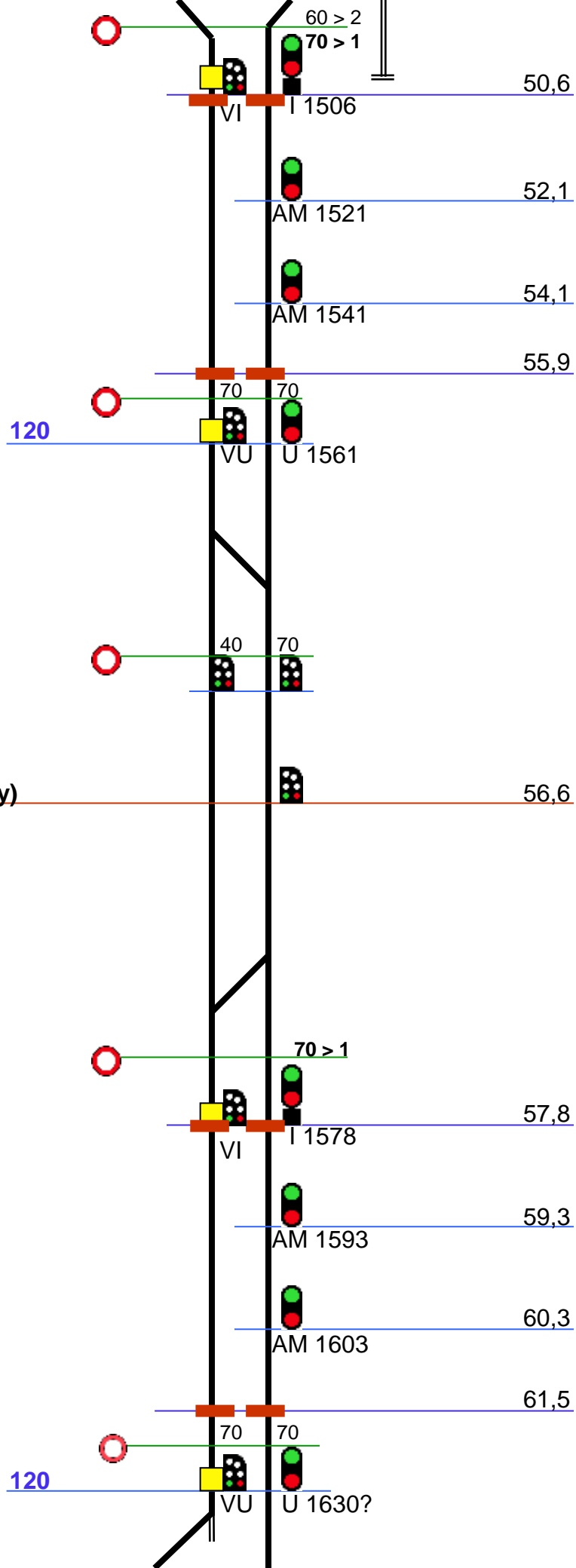

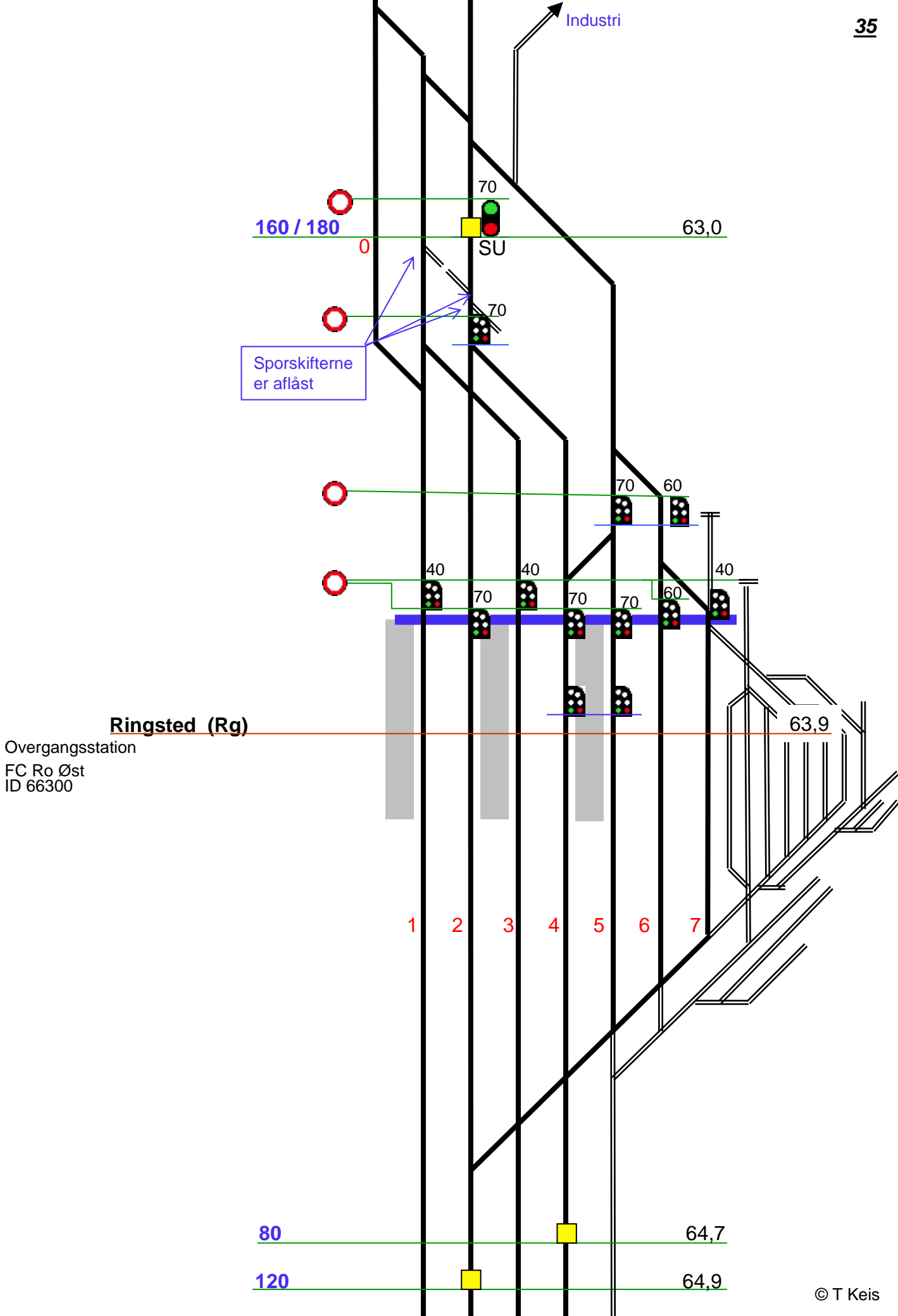

Ringsted (Rg)

Overgangsstation
FC Ro Øst
ID 66300

Linieblok
FC Ro Vest

FC Ro Vest

Fjenneslev (Fj)

Glumsø (Gz)

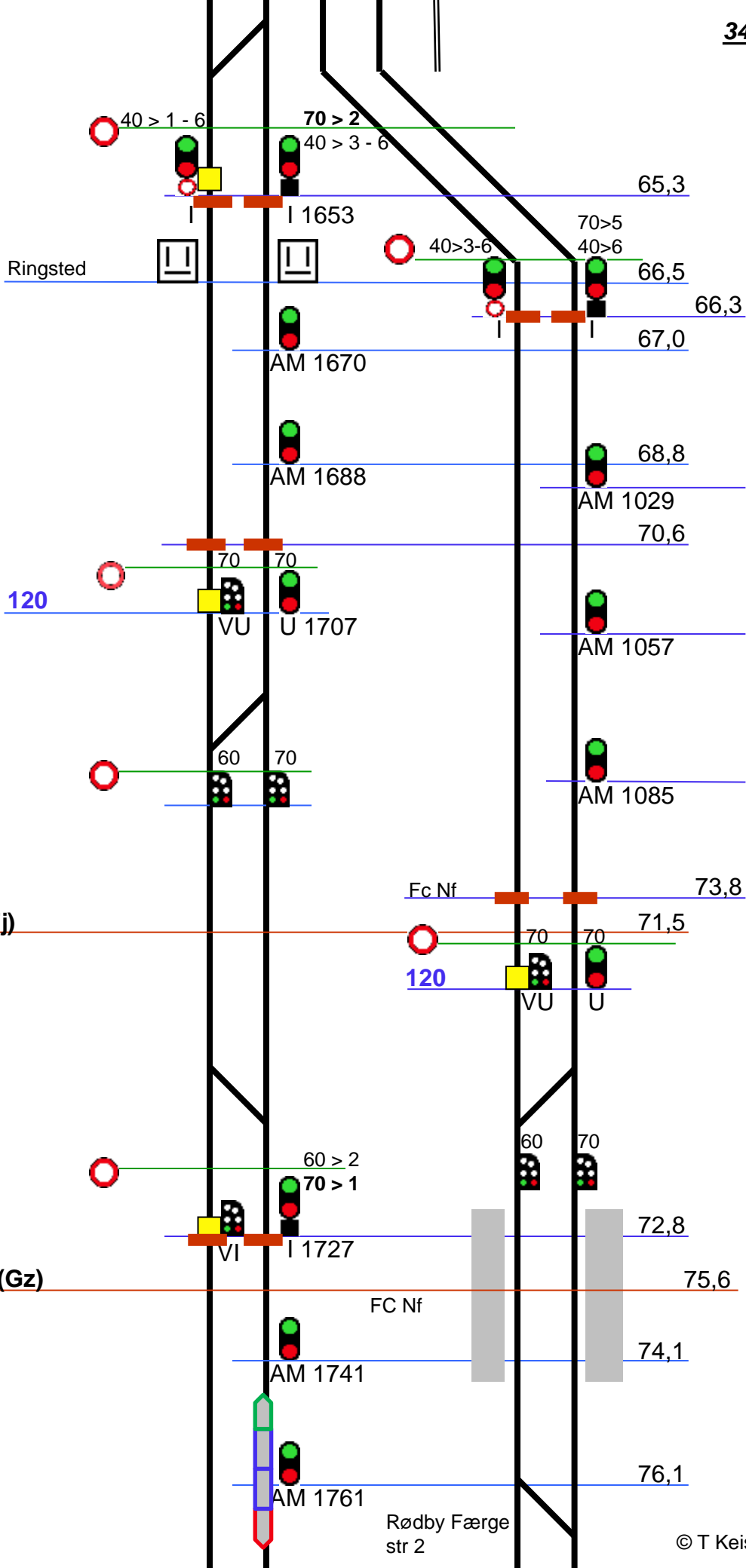

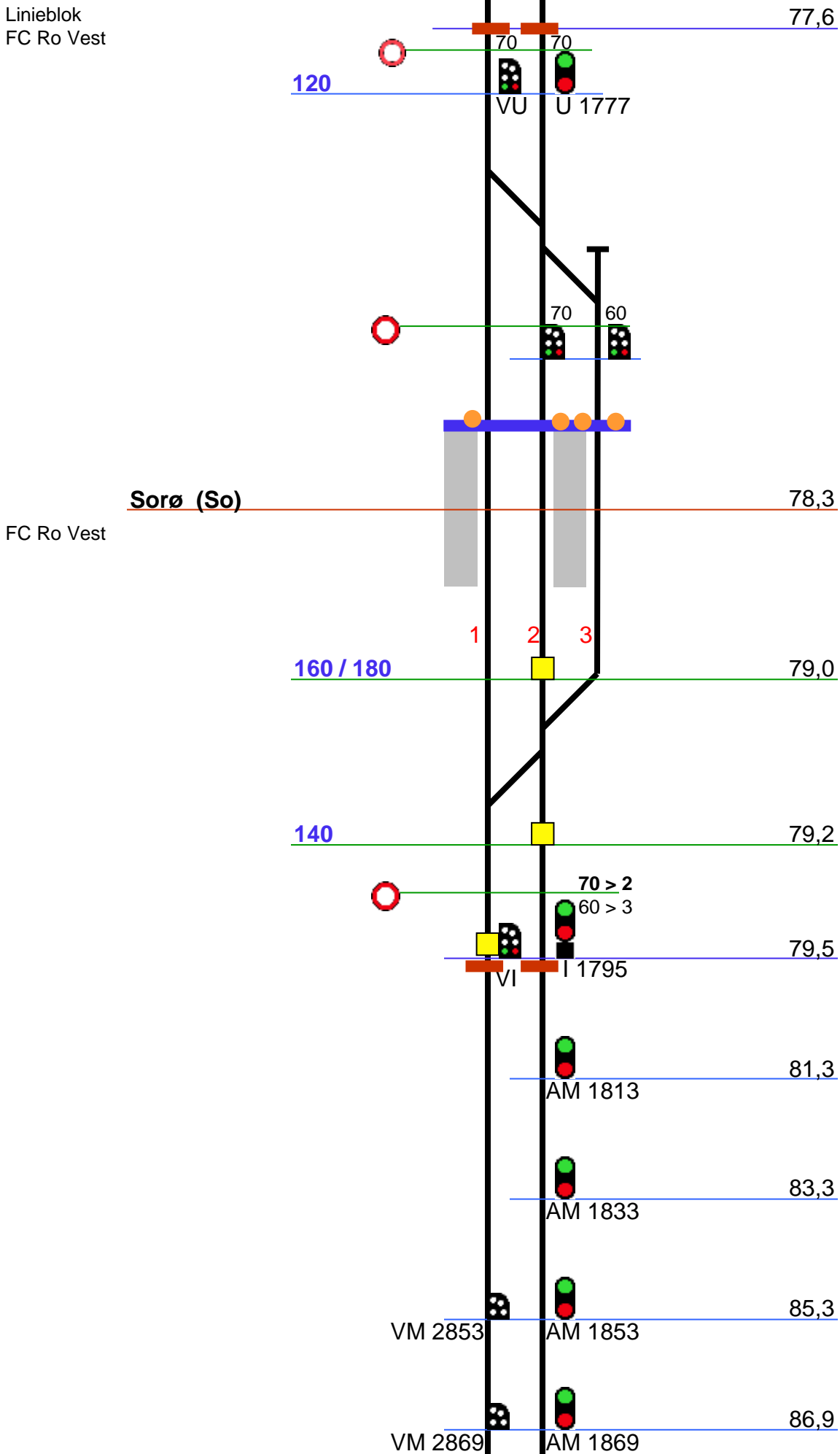

Linieblok
FC Ro Vest

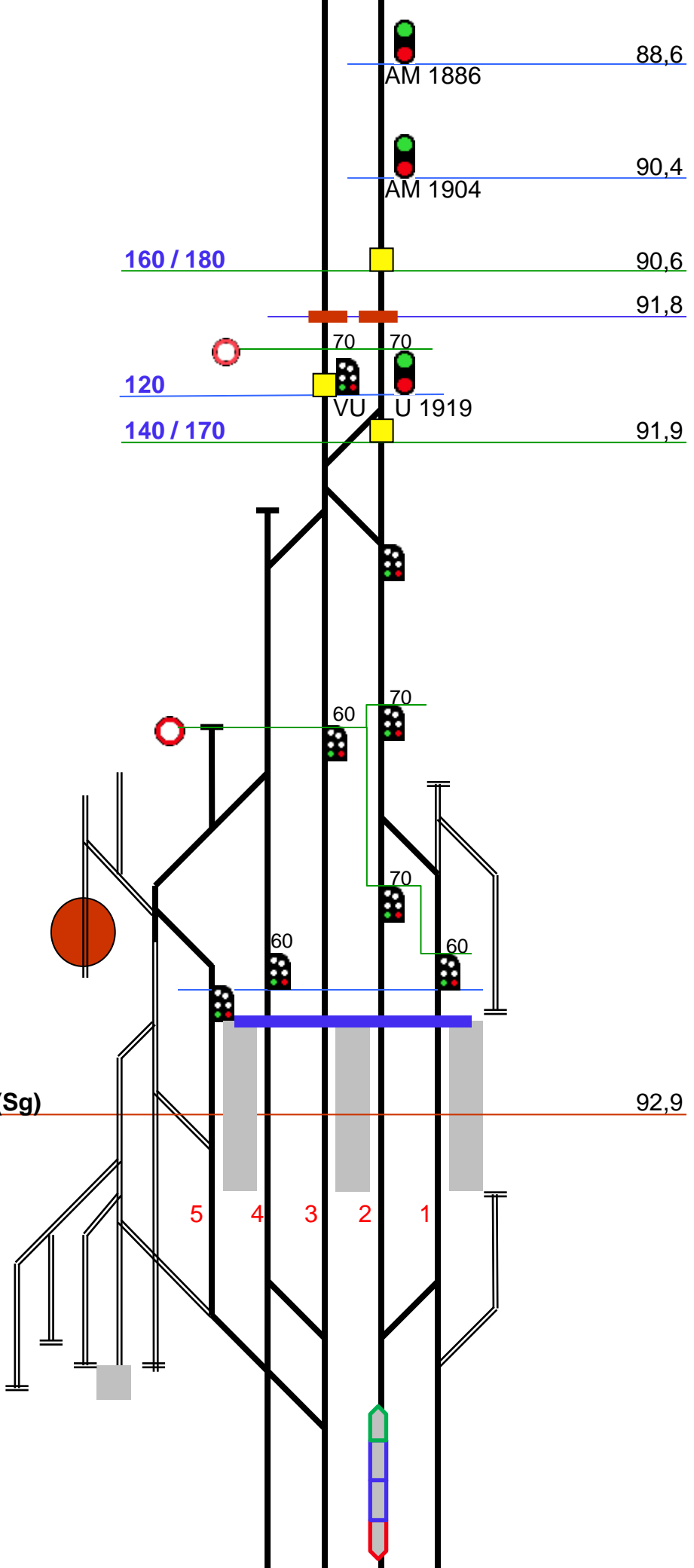

88,6

AM 1886

90,4

AM 1904

160 / 180

90,6

91,8

120

70

70

140 / 170

VU

U 1919

91,9

92,9

Slagelse (Sg)

Overgangsstation
FC Ro Vest
ID 61051

5 4 3 2 1

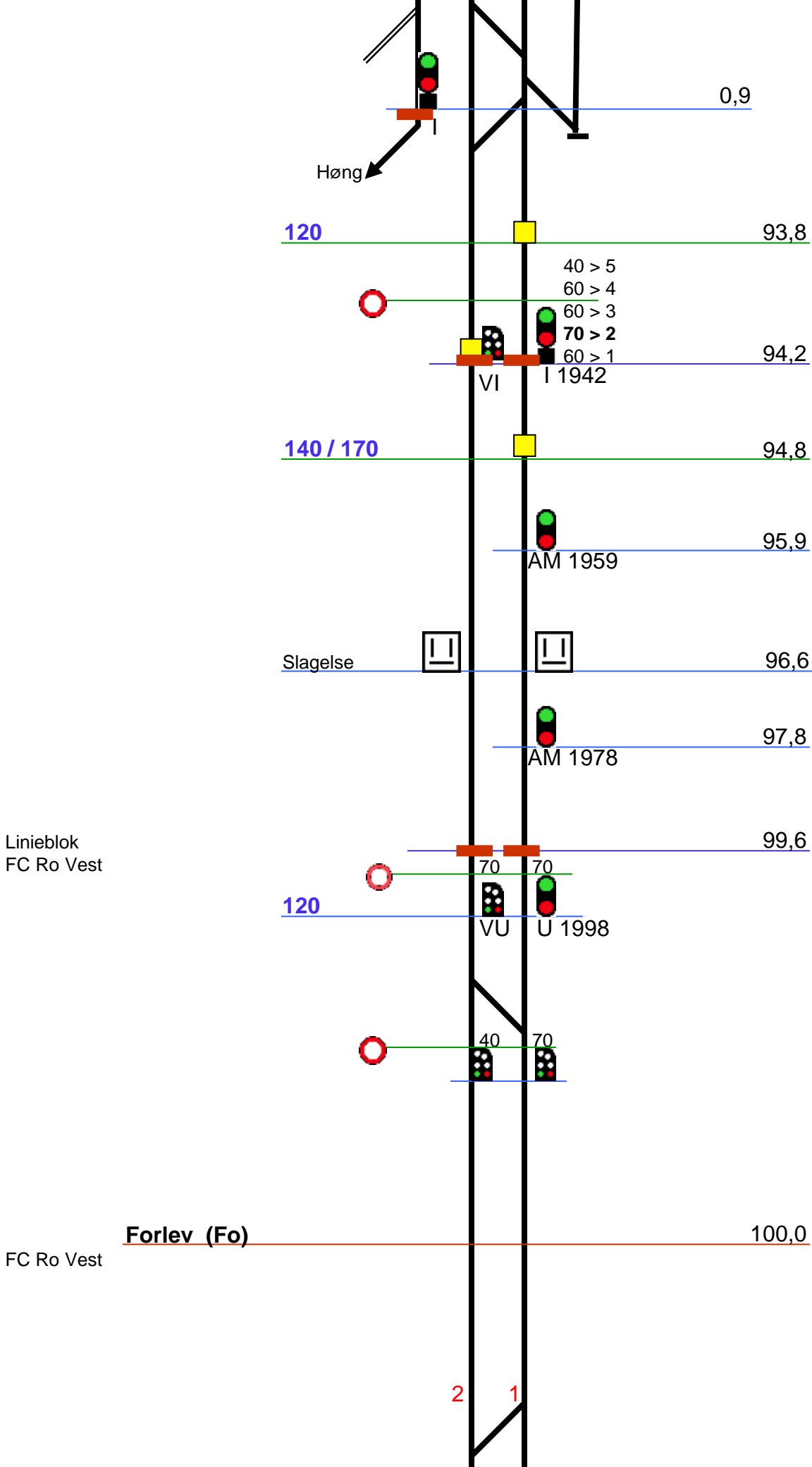

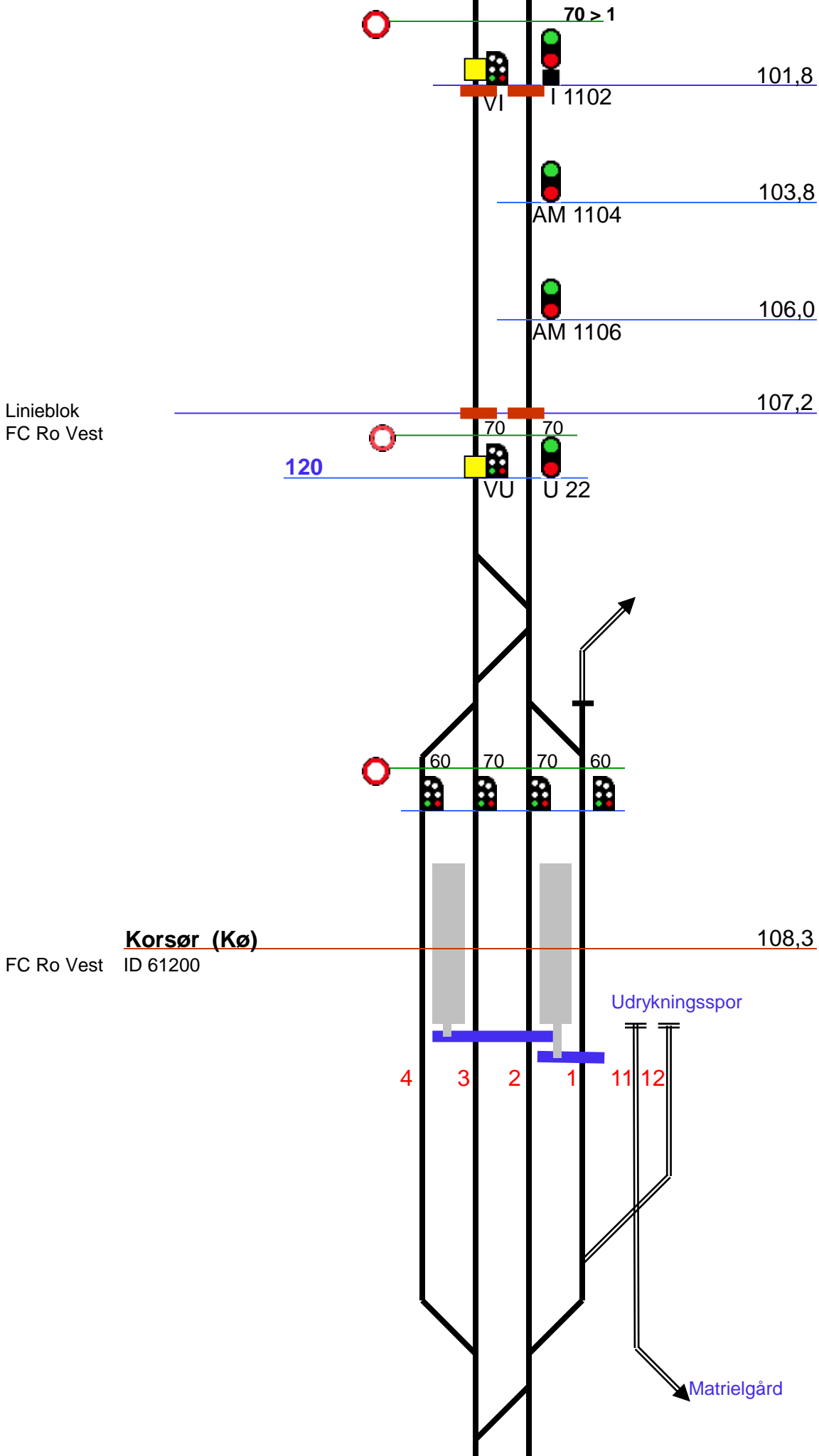

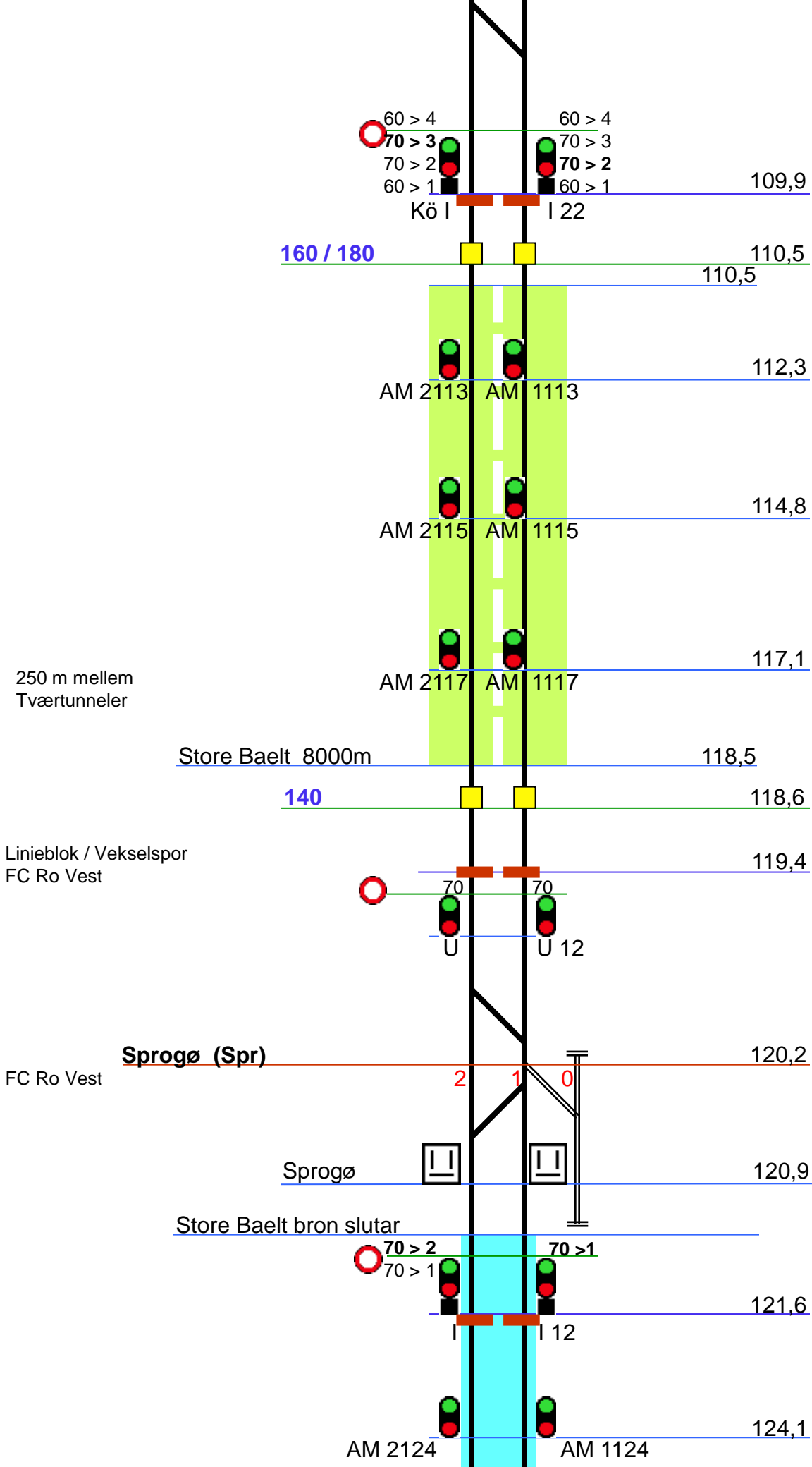

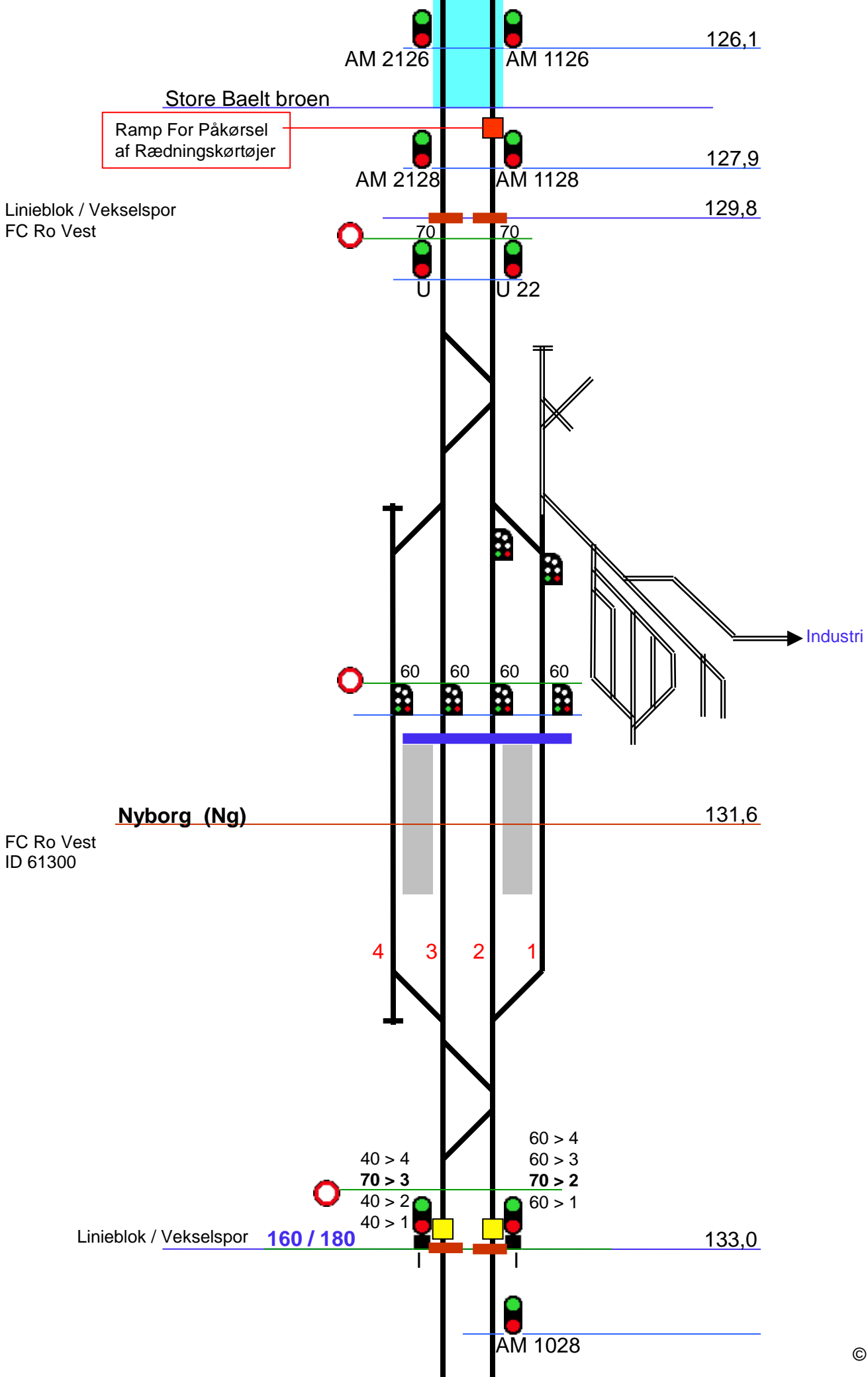

Linieblok
FC Ro Vest

135,6

120



70



VU

70



U 1045

Hjulby (Ju)

136,6

FC Ro Vest

1

2



70 > 2



VI



I 1059

137,2

139,2



AM 1079

Linieblok
FC Ro Vest

141,0

120



70



VU

70



U 1189



70



50



Ullerslev (Uv)

141,5

FC Ro Vest

1

2

3

Linieblok
FC Ro Øst

Langeskov (Lv)

Marslev (Mv)

FC Ro Vest

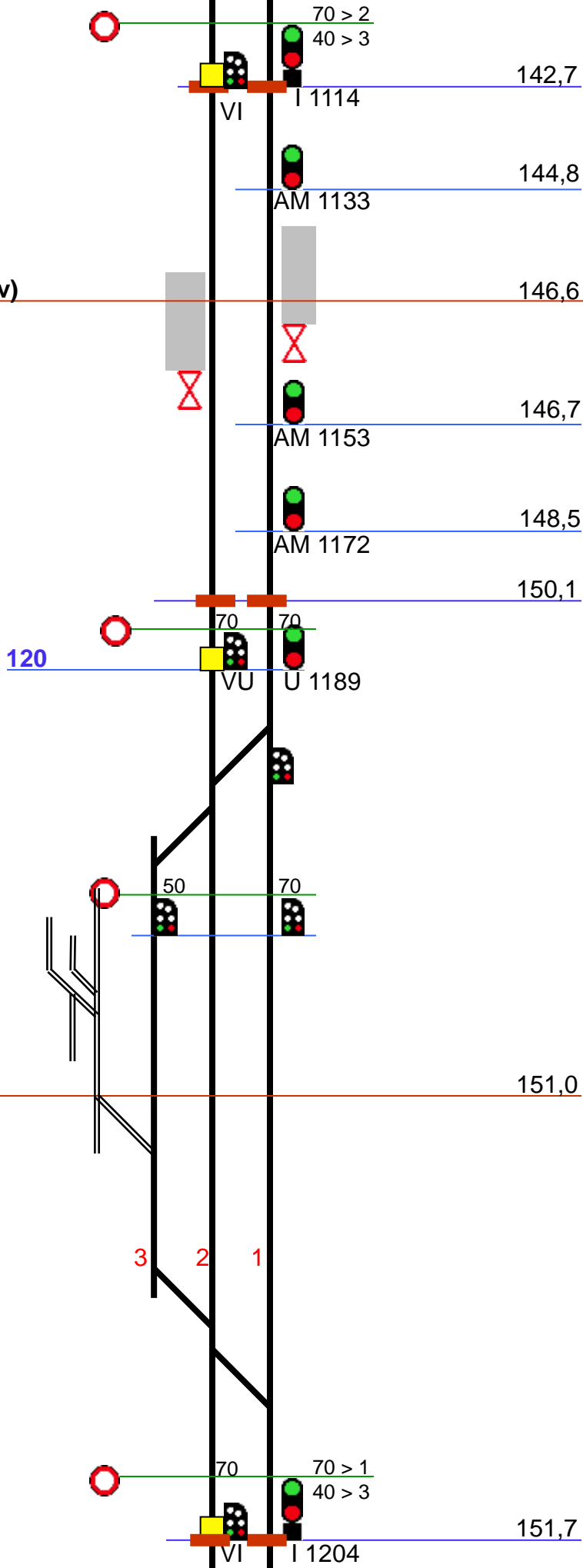

Marslev



153,1

153,7



AM 1224

155,7



AM 1244

157,7



AM 1264

Kaertemindesporet

160 / 180

159,6

Linieblok
FC Ro Vest



70

70

120



VU



U

1284

70

40

60

40

40

Odense (Od)

160,3

Overgangsstation
ID 66800

8

7

6

5

4

3

2

1

21

22

23

24

25

26

27

28

Jernbanemuseum

21 22 23 24 25 26 27 28

8 7 6 5 4 3 2 1

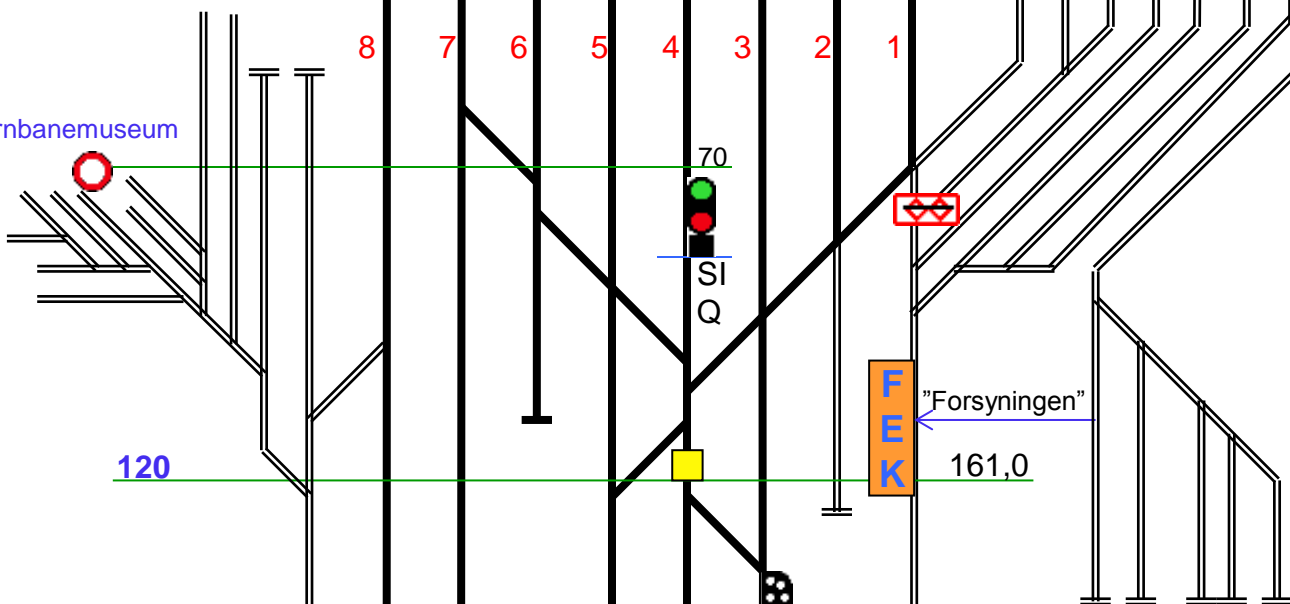

120

F
E
K

"Forsyningen"

161,0

- 40 > 7
- 40 > 6
- 70 > SI**
- 40 > 3
- 40 > 2

70>8
70>7
40>6

161,8



100 / 110

90

VI

I

161,9

1,5

F56

AM 1316

"Hullet"
(Hålet)

162,9

140 / 160

AM 1336

Odense Sygehus (Oss)

AM 1356

3,8

Linieblok
FC Fa

168,3

120

70 70

100

Svendborg
str 21

4,0

VU U

FC Fa

Holmstrup (Hp)

169,1

2 1

60 > 2
70 > 1

169,6

VI

AM 1399

AM 1419

140 / 170

173,9

Linieblok
FC Fa

174,6

120

VU

U

FC Fa

Tommerup (Tp)

175,5

3 2 1



70 > 2
60 > 1

176,3



VI

I



AM 1473

Skalbjerg (Sc)

178,8

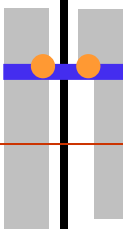

140 / 160

179,1



VM 2490

AM 1490

Bred (Bd)

181,1

Linieblok
FC Fa

183,4

Årup (Ap)

184,7

FC Fa

120



VU

U

70



60



2

1

3

1a

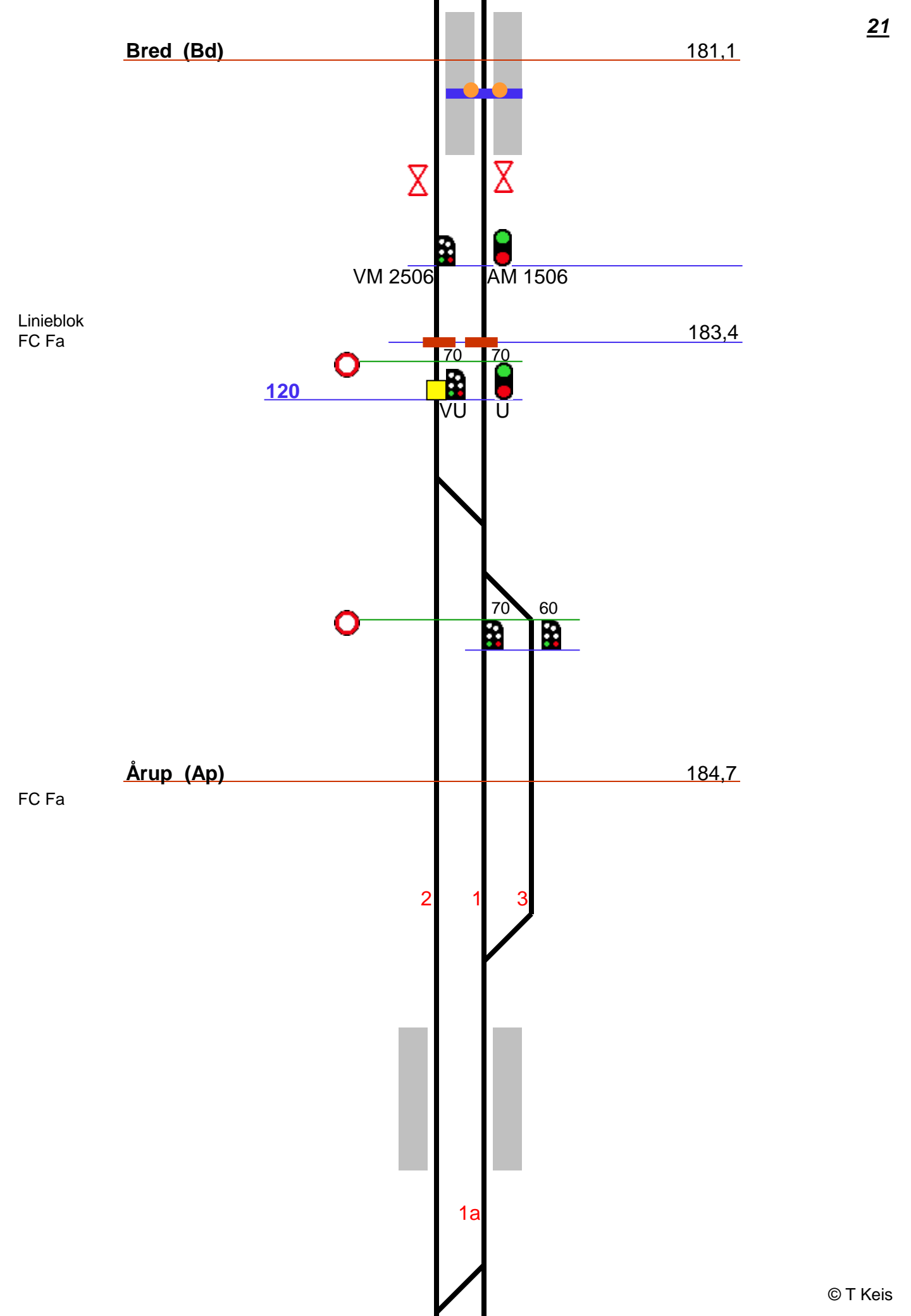

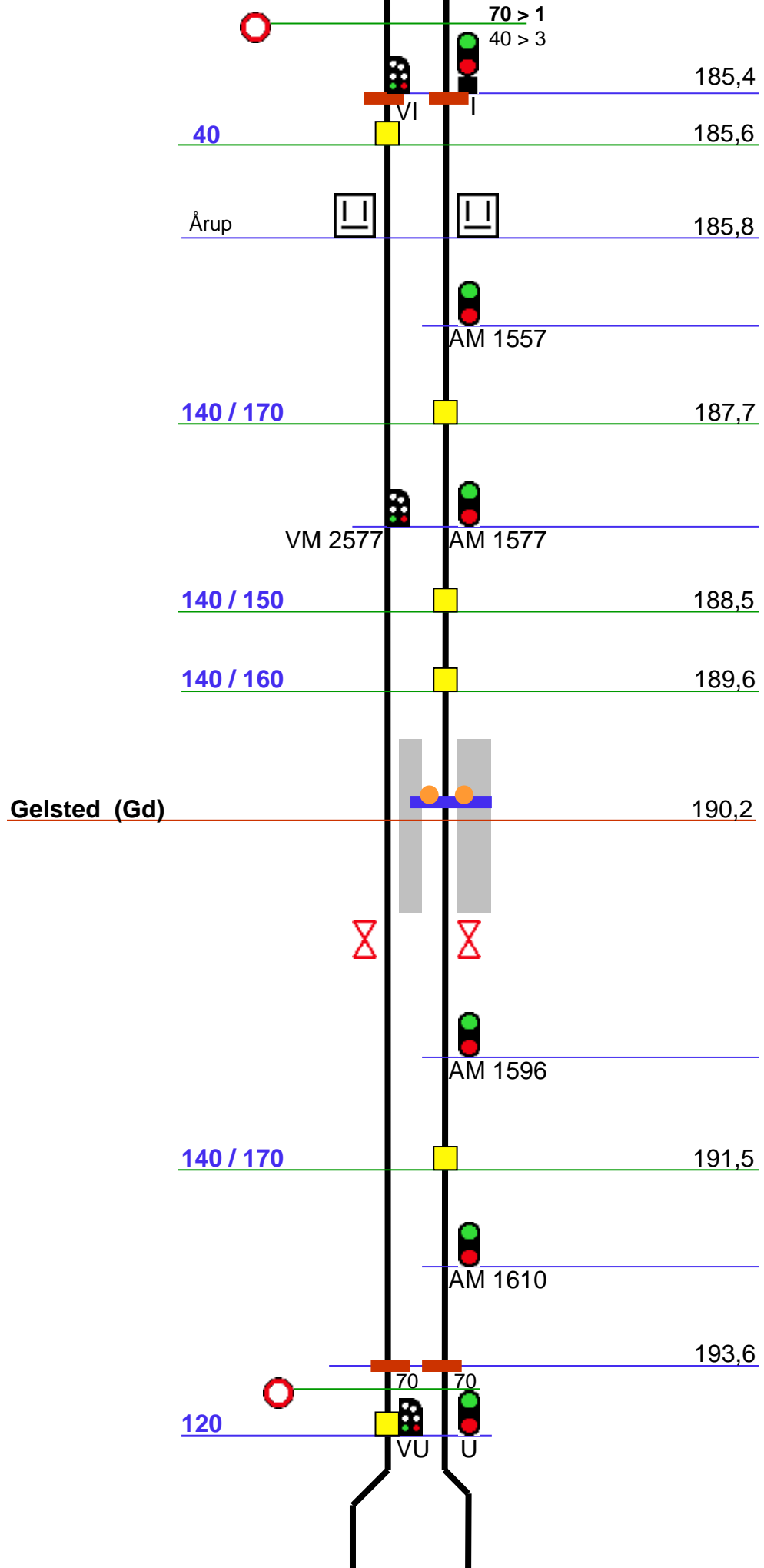

Linieblok
FC Fa

FC Fa

Ejby (Eb) 194,8

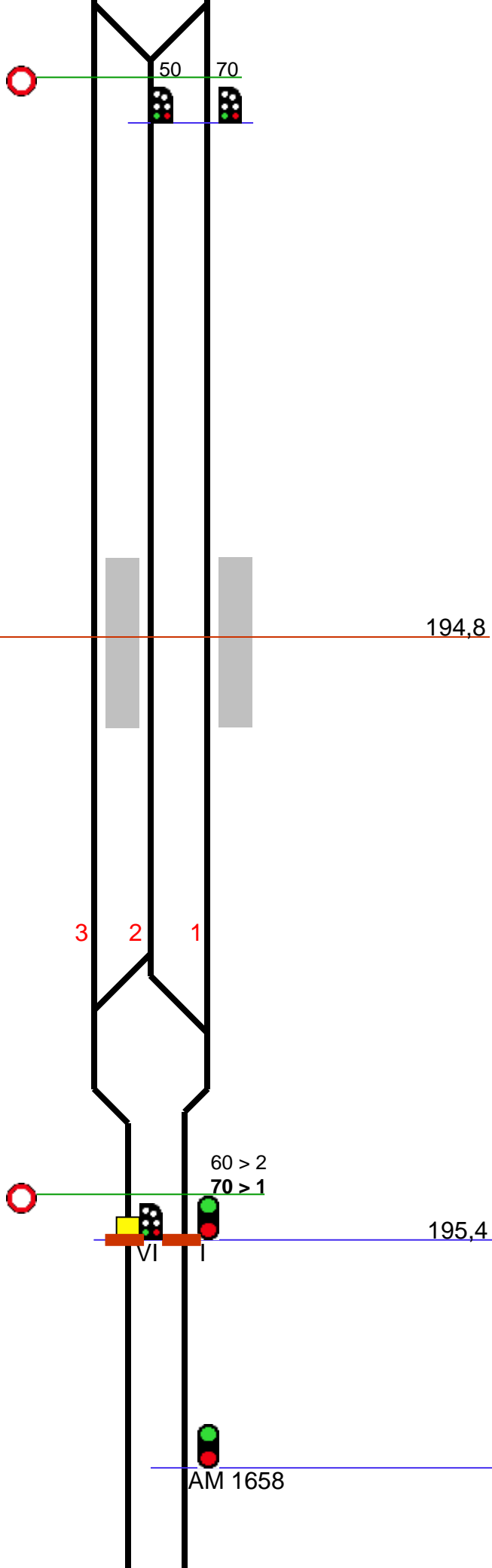

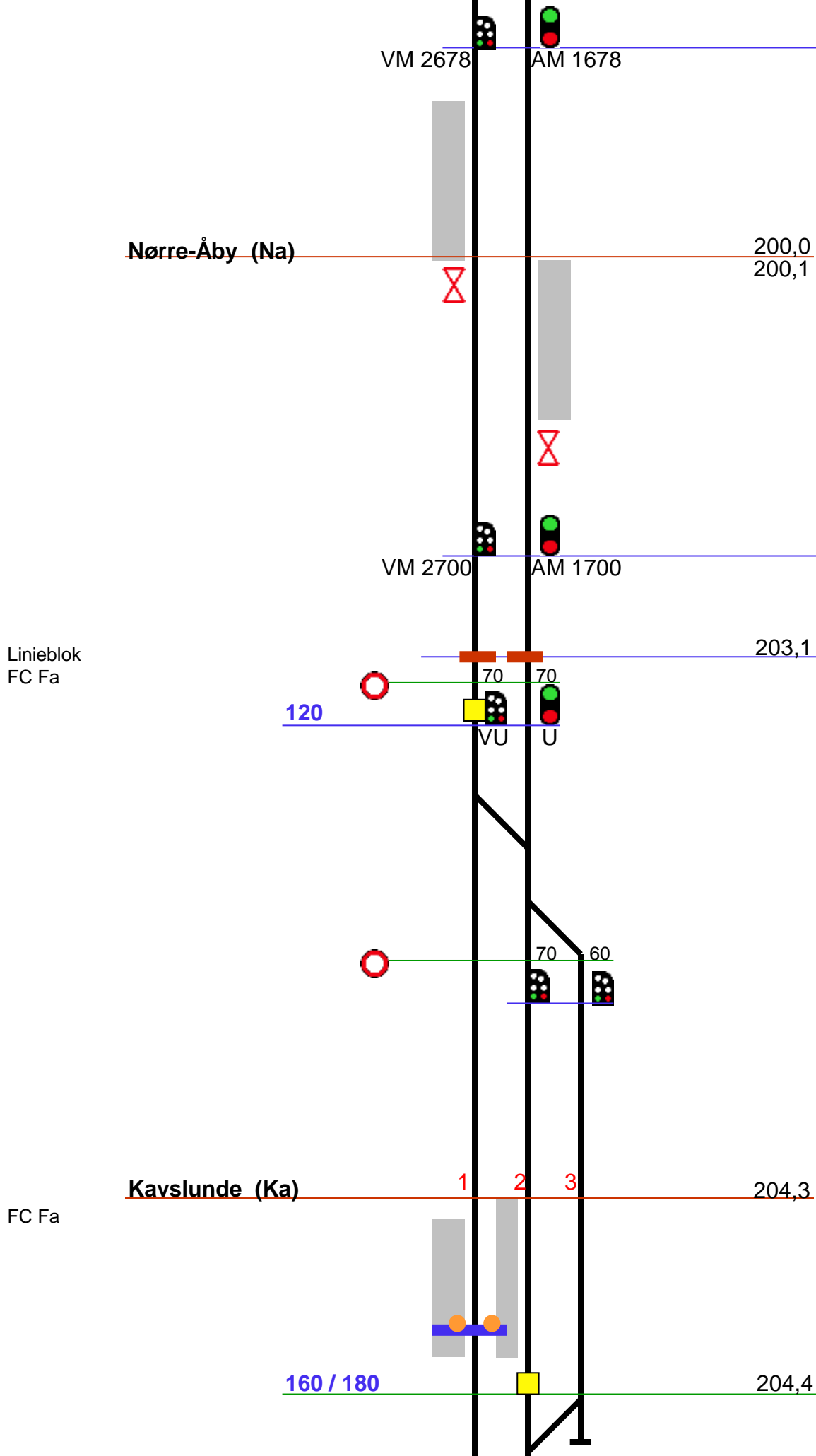

Linieblok
FC Fa

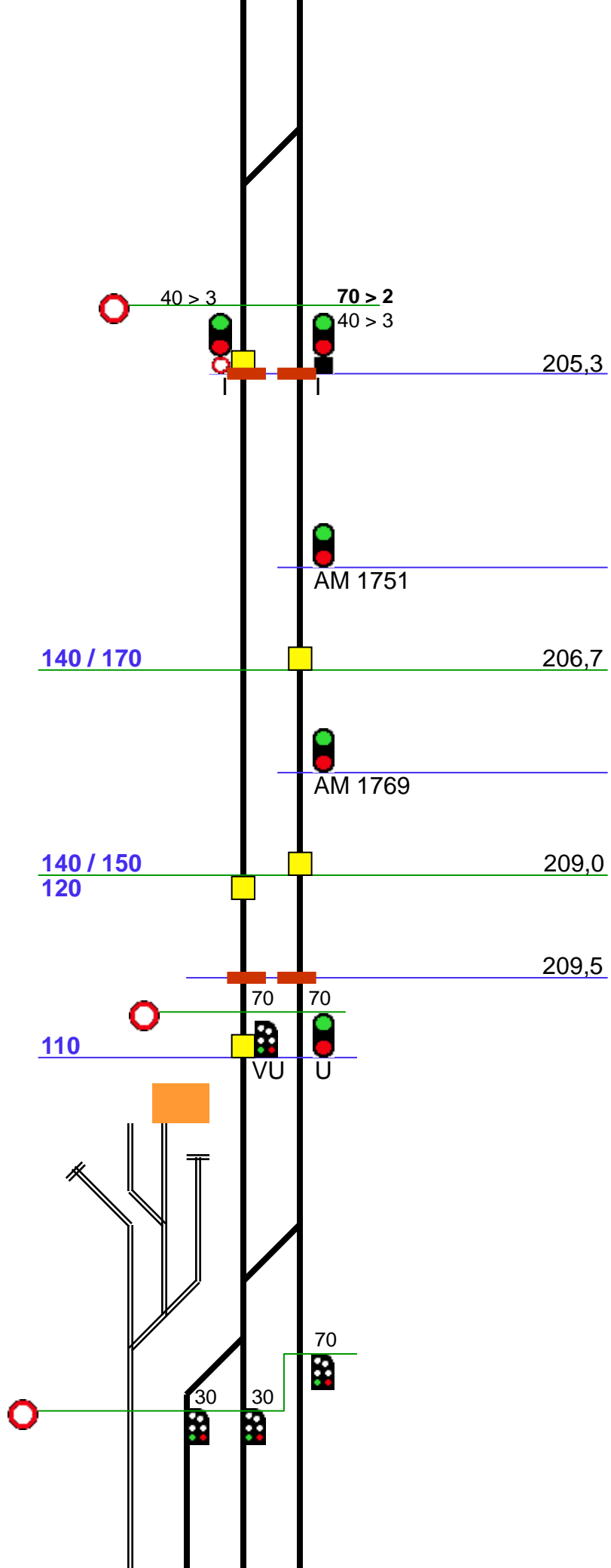

120 / 130

209,8

Middelfart (Md)
ID 67900

210,4

FC Fa

110 / 130

210,6

1 3 4

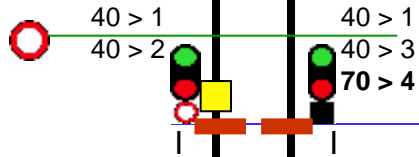

211,2

Lille Bælt bron slutar

Lille Bælt bron

AM 1820

120 / 130

213,2

Linieblok
FC Fa

214,5

120

70

70

VU

U

120

215,9

2

1

Snoghøj (Sno)

216,3

FC Fa

70 > 2

40 > 1

70 > 2

40 > 2

70 > 1

90 / 100

70 > 1

216,5

216,6

216,7

Fredericia

AM 2219

AM 1219

hsp 2

1

Linieblok
FC Fa

Linieblok / Vekselspor

FC Fa

220,1

140

70

70

VU

U

70

70

U

U

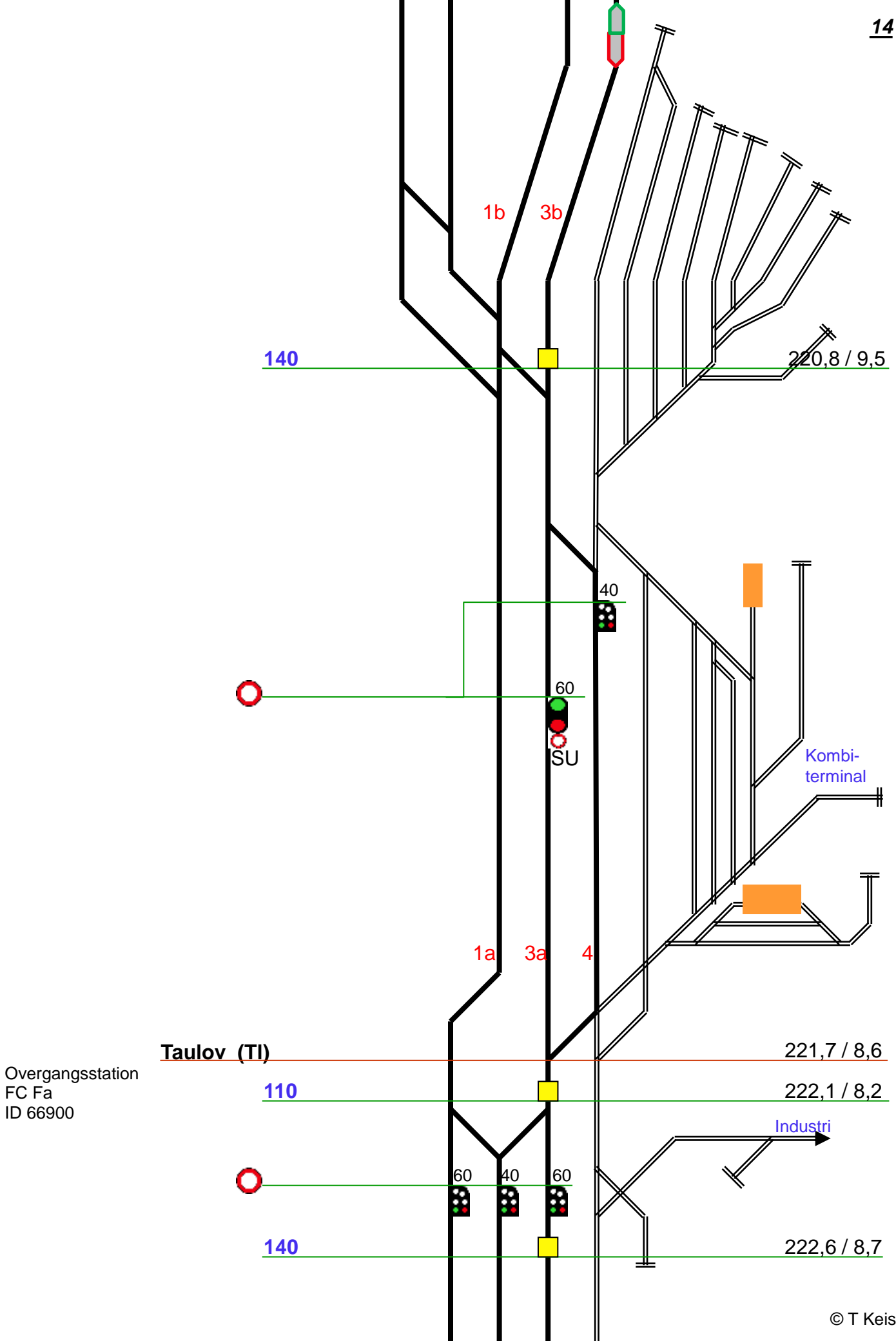

Overgangsstation
FC Fa
ID 66900

Taulov (TI)

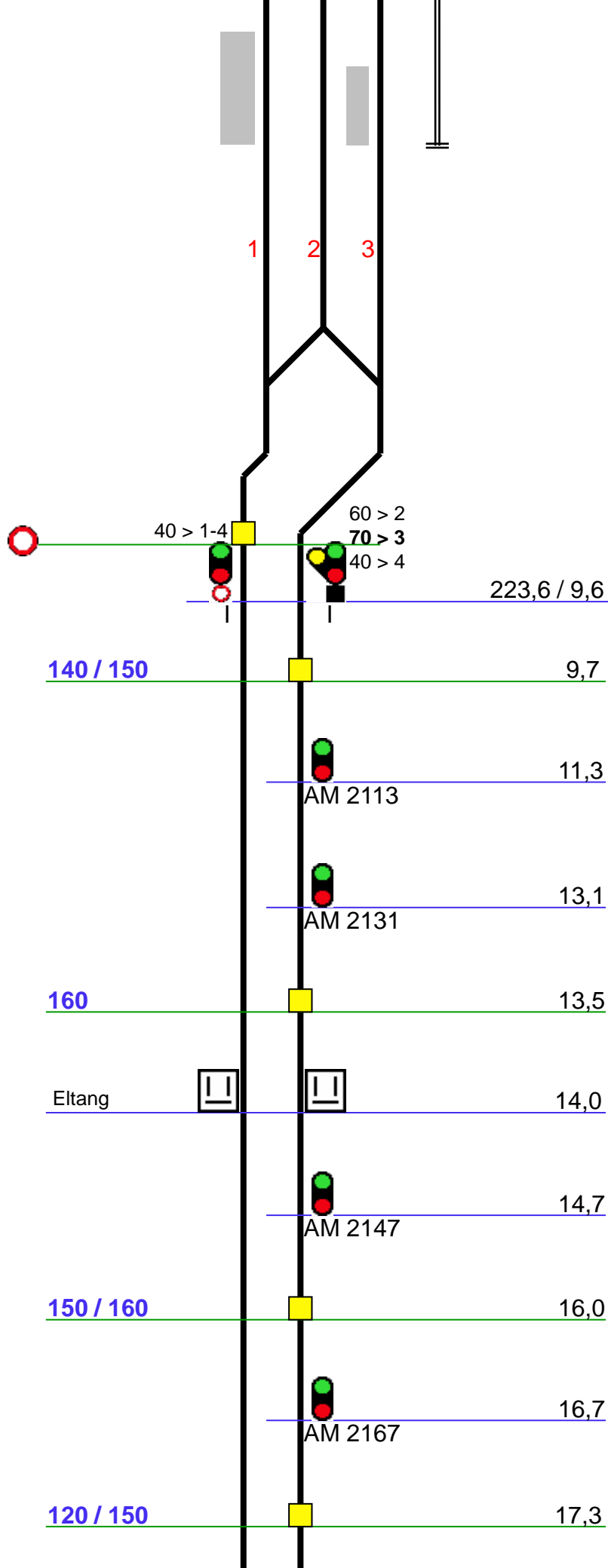

Linieblok
FC Fa

120 / 140 18,3

18,6

120 / 130
120 18,8

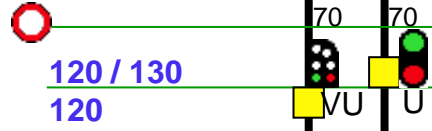

70 40

Kolding (Kd)
FC Fa
ID 62027

19,9

120 20,1

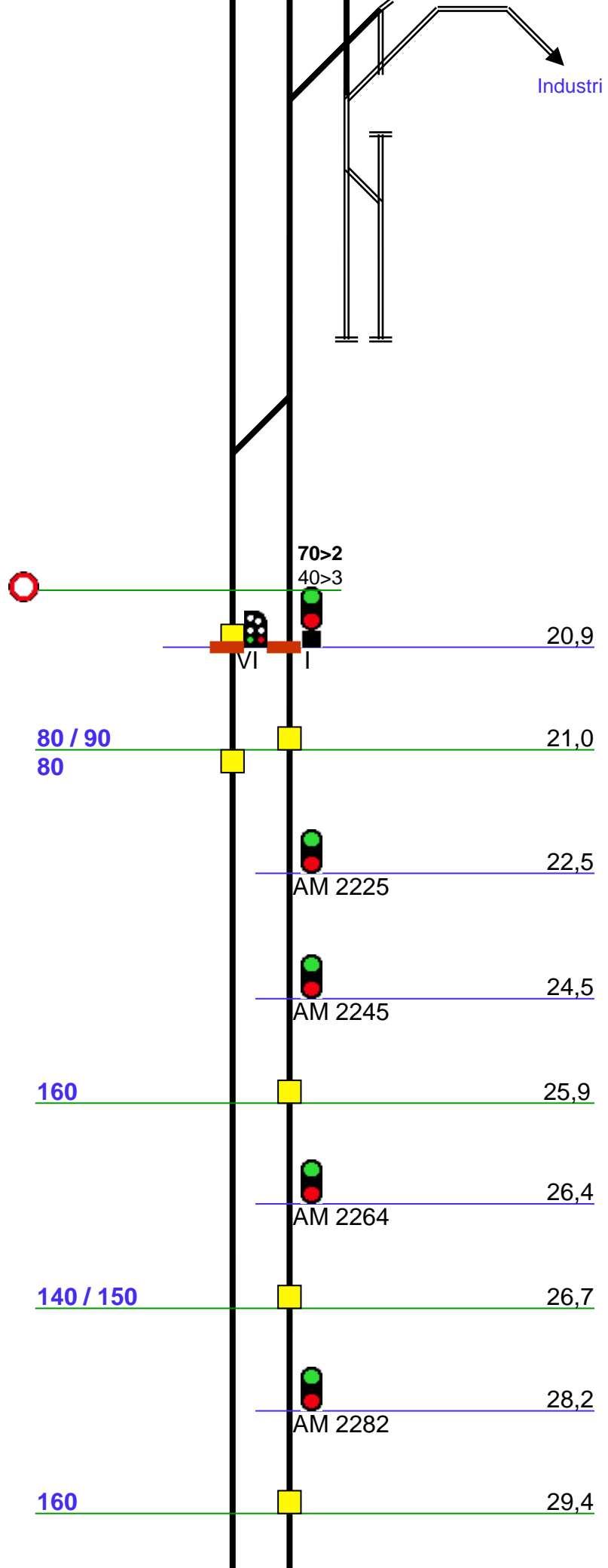

Linieblok
FC Fa

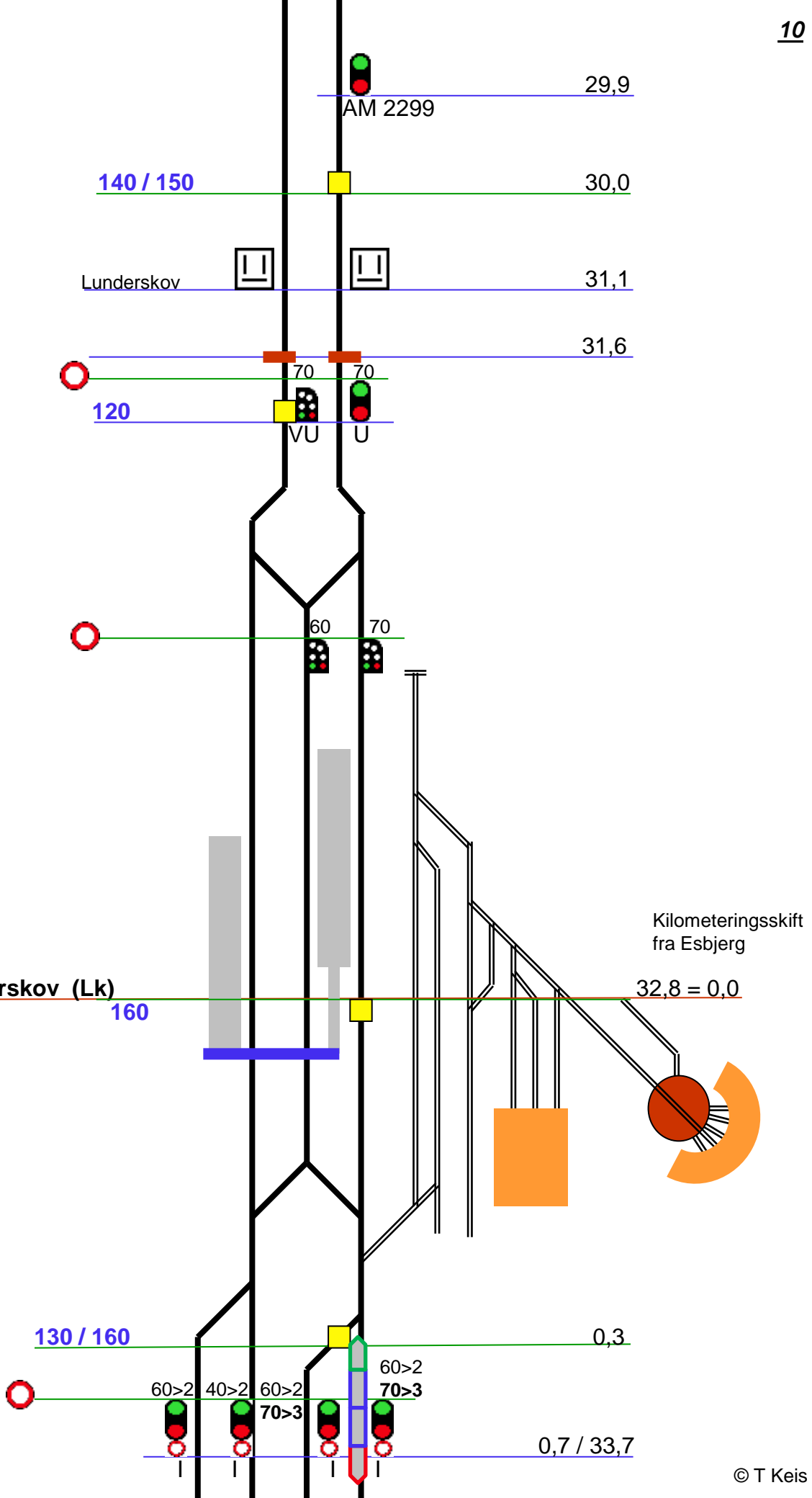

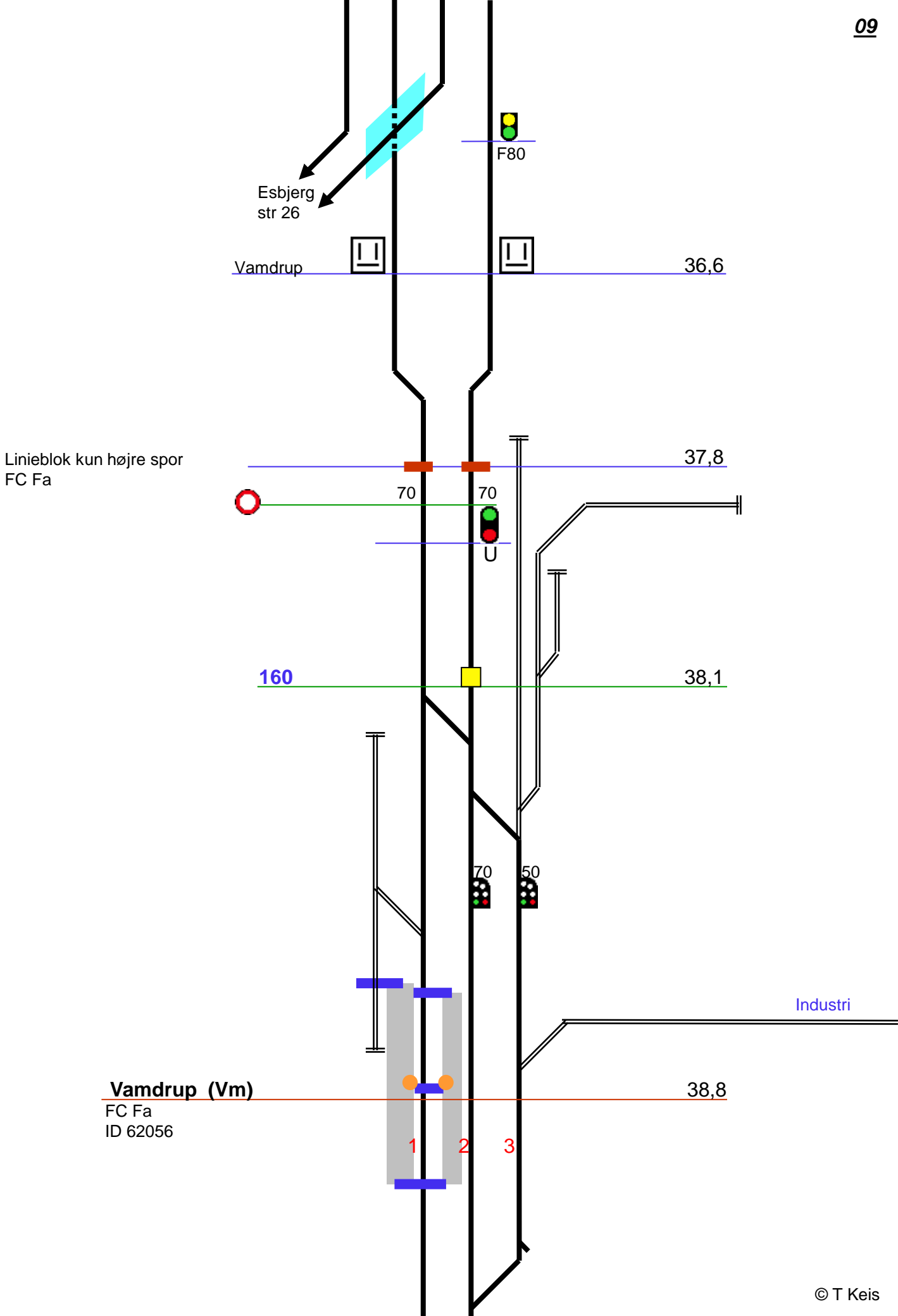

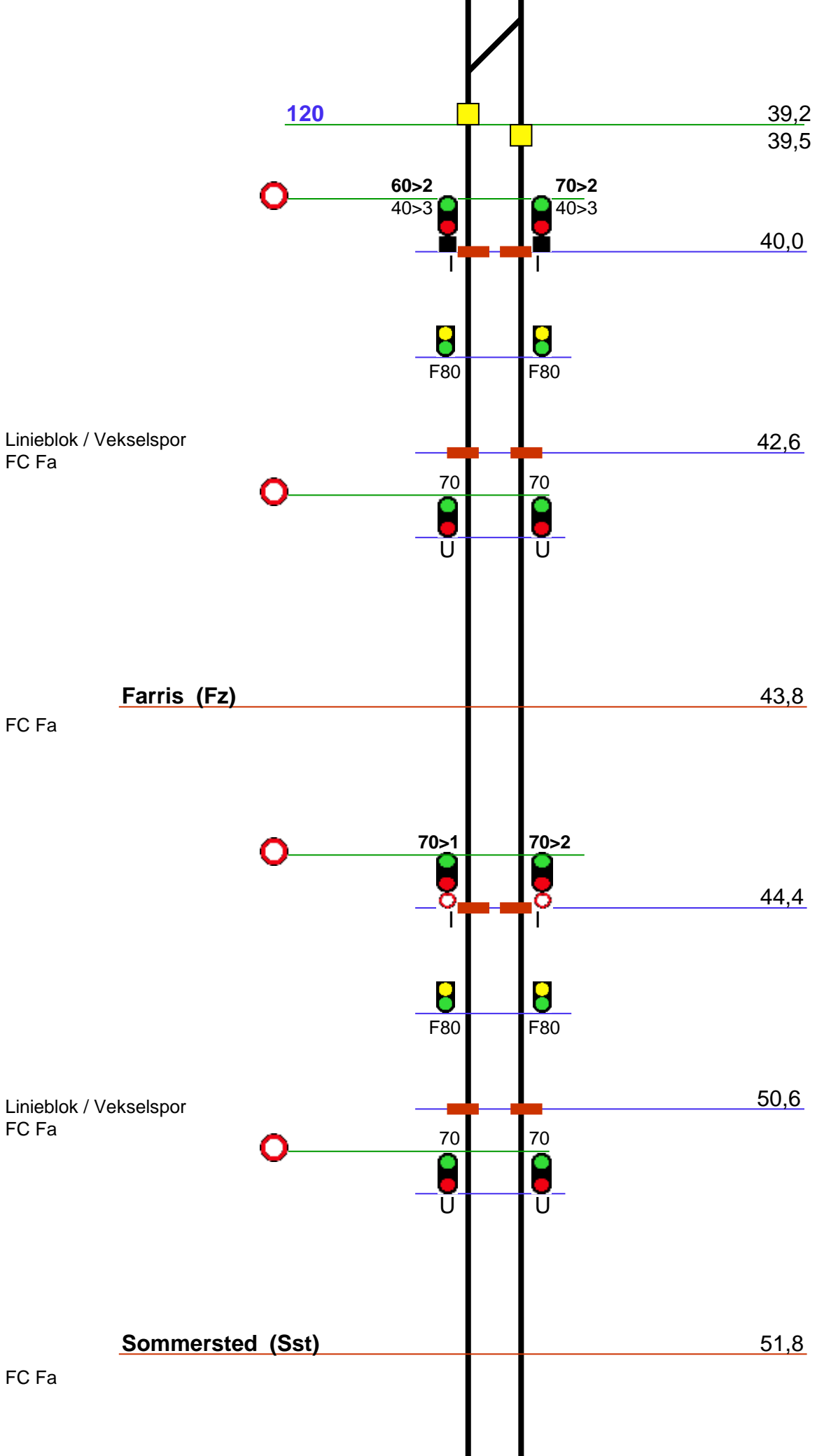

Linieblok / Vekselspor
FC Fa

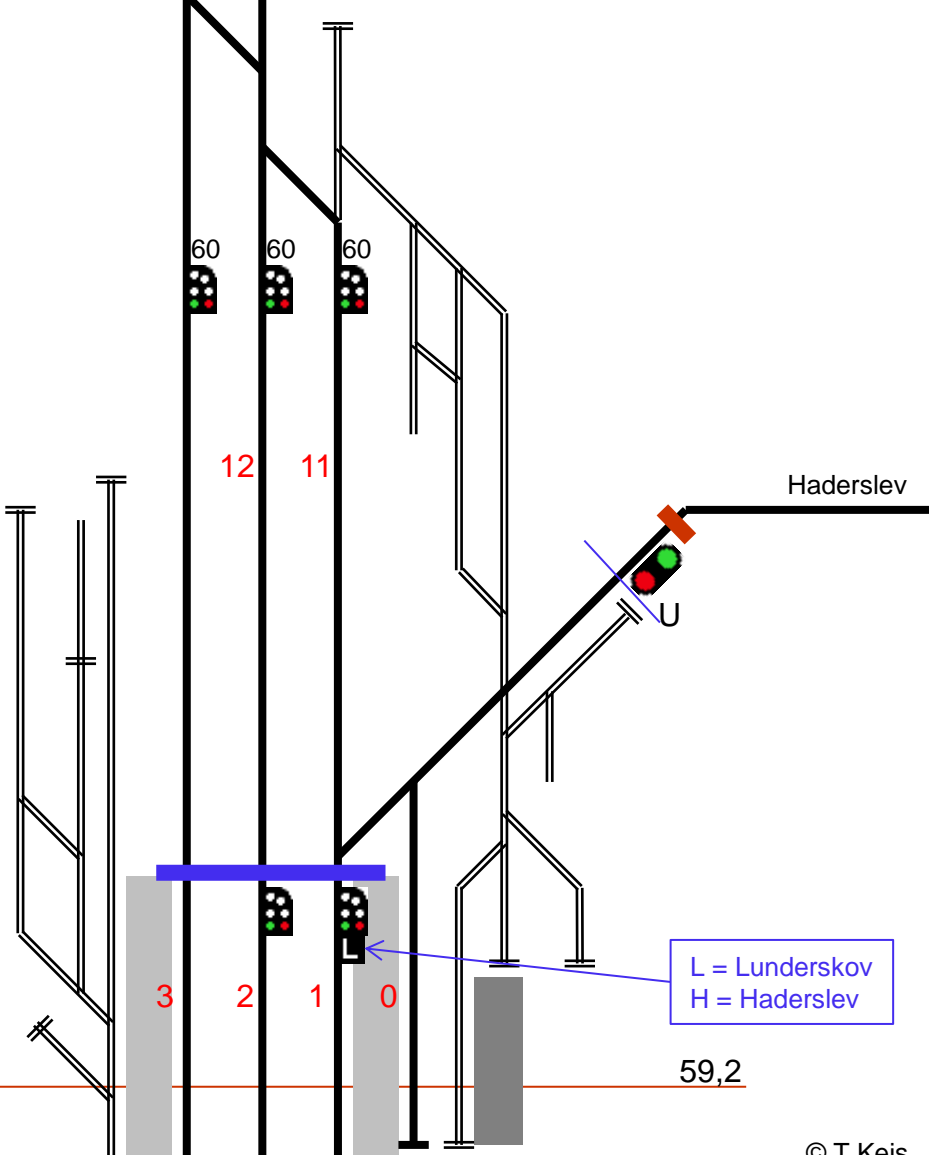
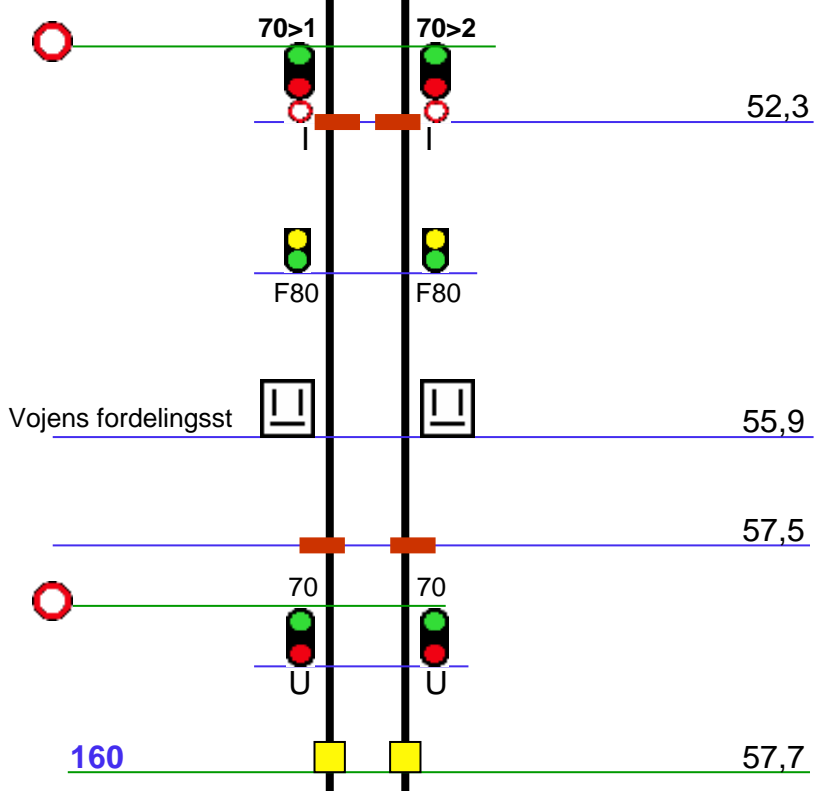

Vojens (Oj)
FC Fa
ID 62066

L = Lunderskov
H = Haderslev

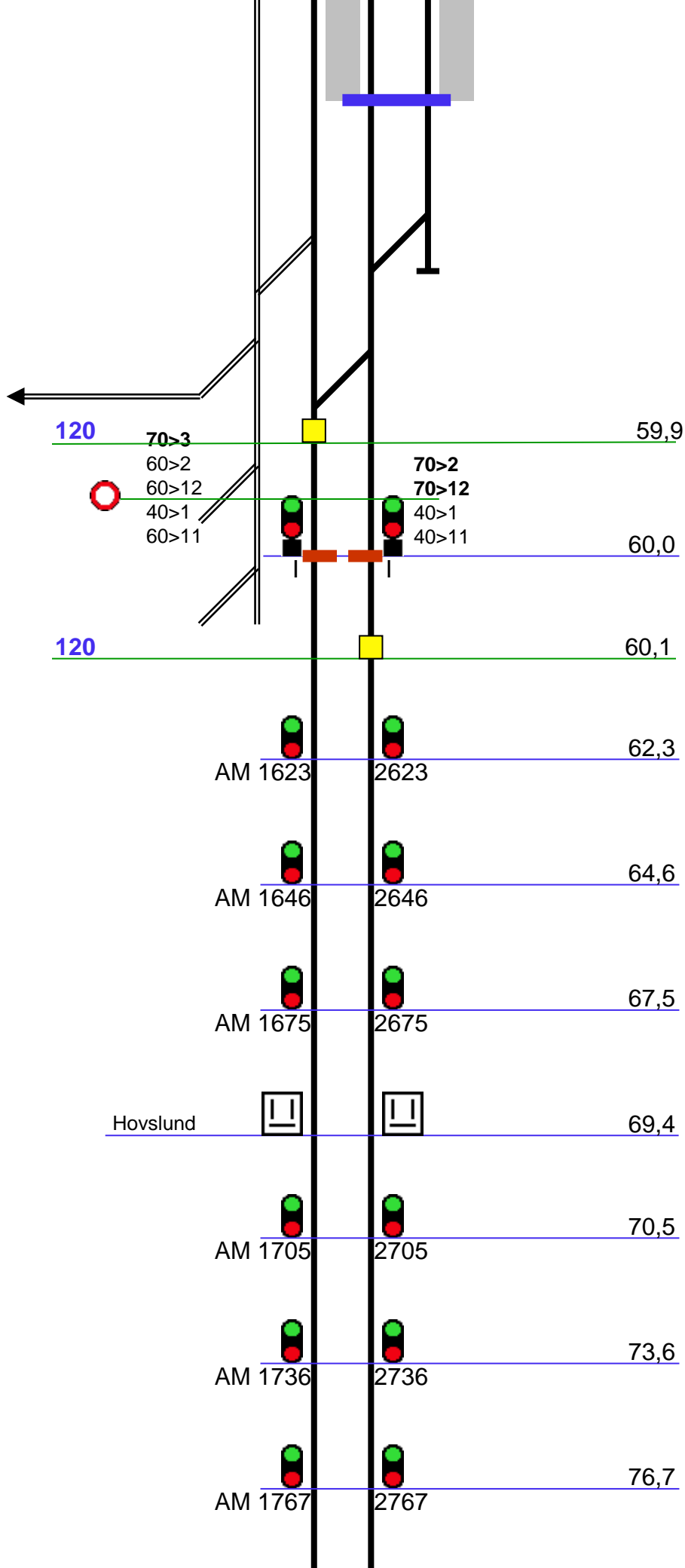

160 / 180

78,2

78,2

78,3

70

70



U

U

Ved berejning af udsigtslængde
jf SR bilag 3 anvendes
tophastighed 200 km/h

60

60

60



Røde kro (Rg)

79,6

FC Fa

3

2

1

XX,x

Ovk

XX,x

120

80,5



70>1

60>2

60>1



70>2

60>1



120

80,7

Ovk

XX,x

Aabenraa

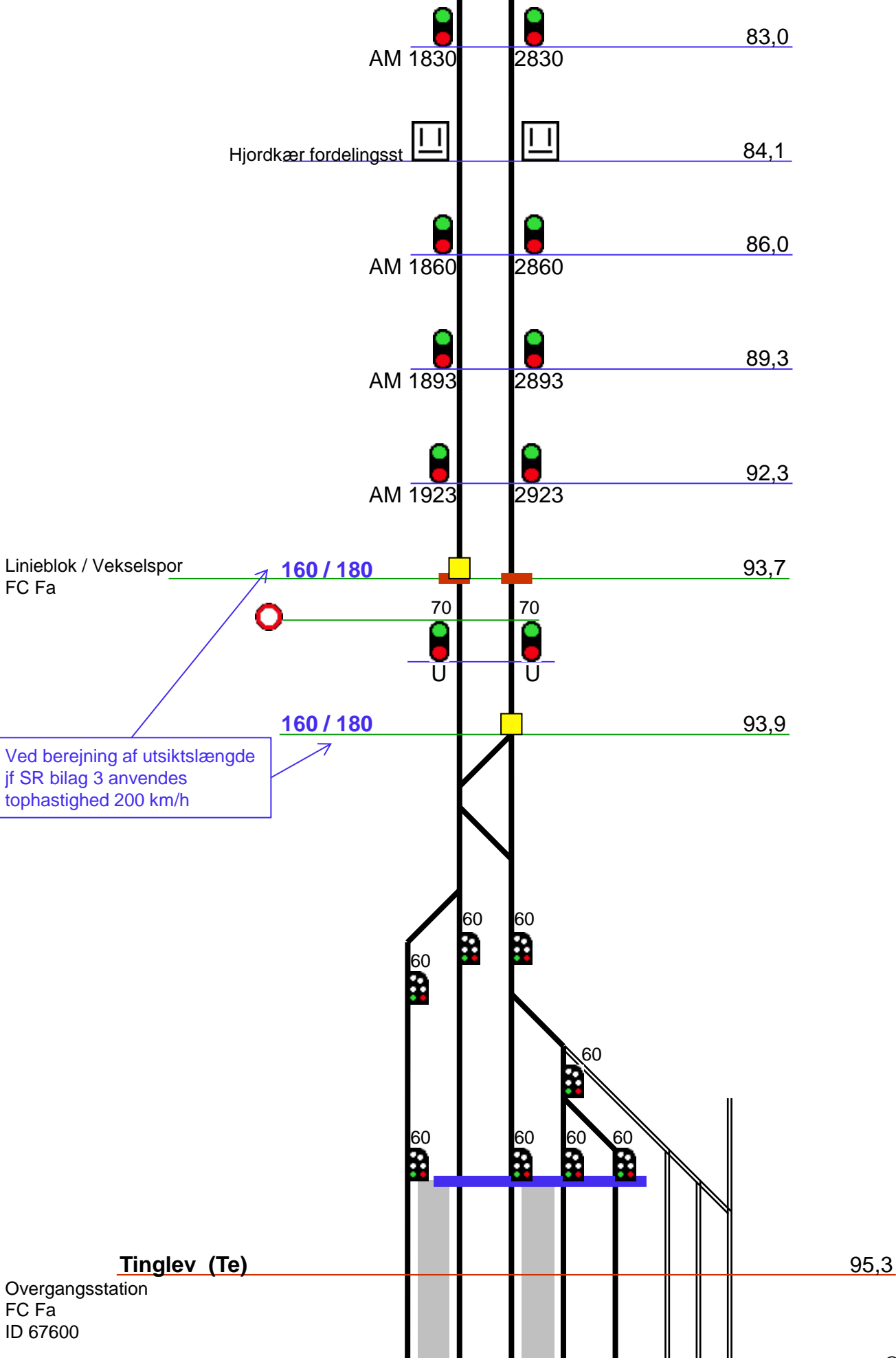

Linieblok / Vekselspor
FC Fa

160 / 180

Ved berejning af udsigtslængde
jf SR bilag 3 anvendes
tophastighed 200 km/h

160 / 180

Industri

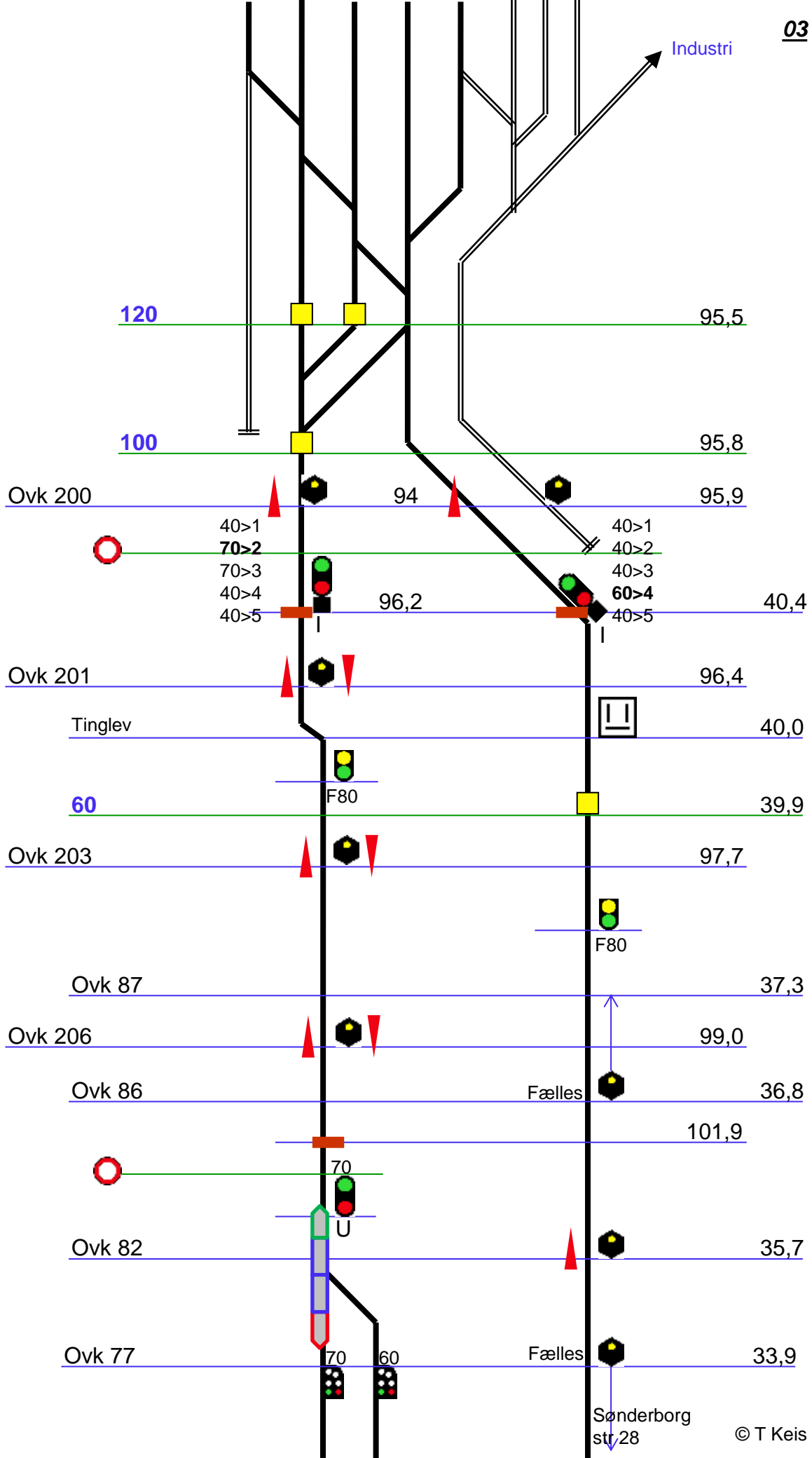

Linieblok
FC Fa

FC Fa

2 1

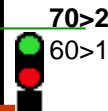

103,6



Ovk 216



105,2

Linieblok
FC Fa



108,4

120



108,9

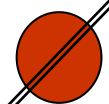

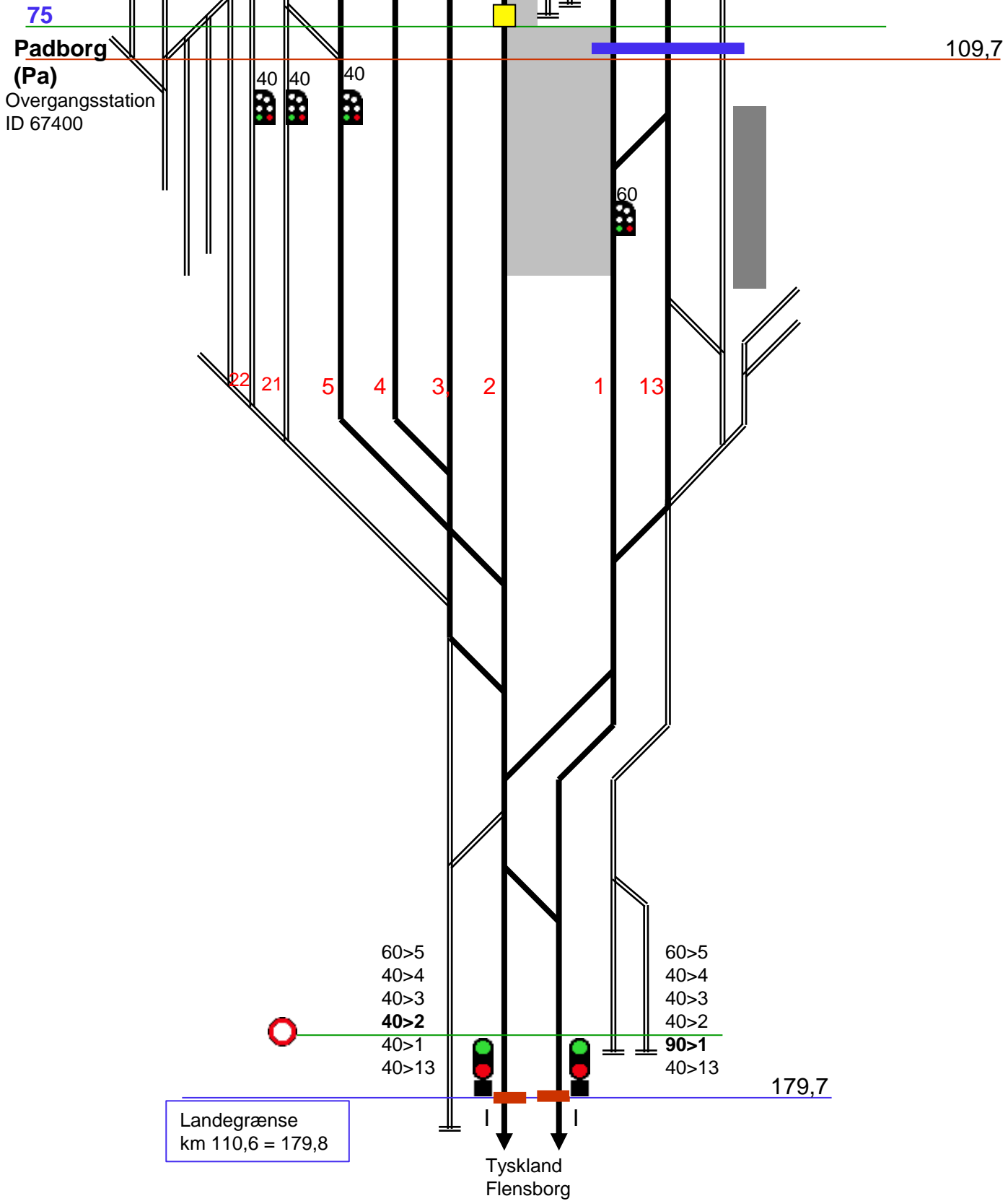

Landegrænse
km 110,6 = 179,8

Tyskland
Flensborg