

Viby J (Vi)

103,7

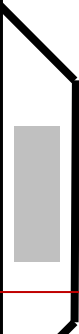

AM 2104

104,x



AM 2102

102,x

140 / 170



101,5



VM 1996



AM 2996

99,6

140 / 150



99,2

Hasselager (Hc)

98,7

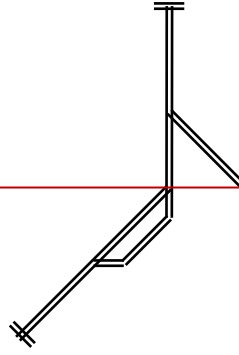

140



98,3

Linieblok
FC Sd

FC Sd

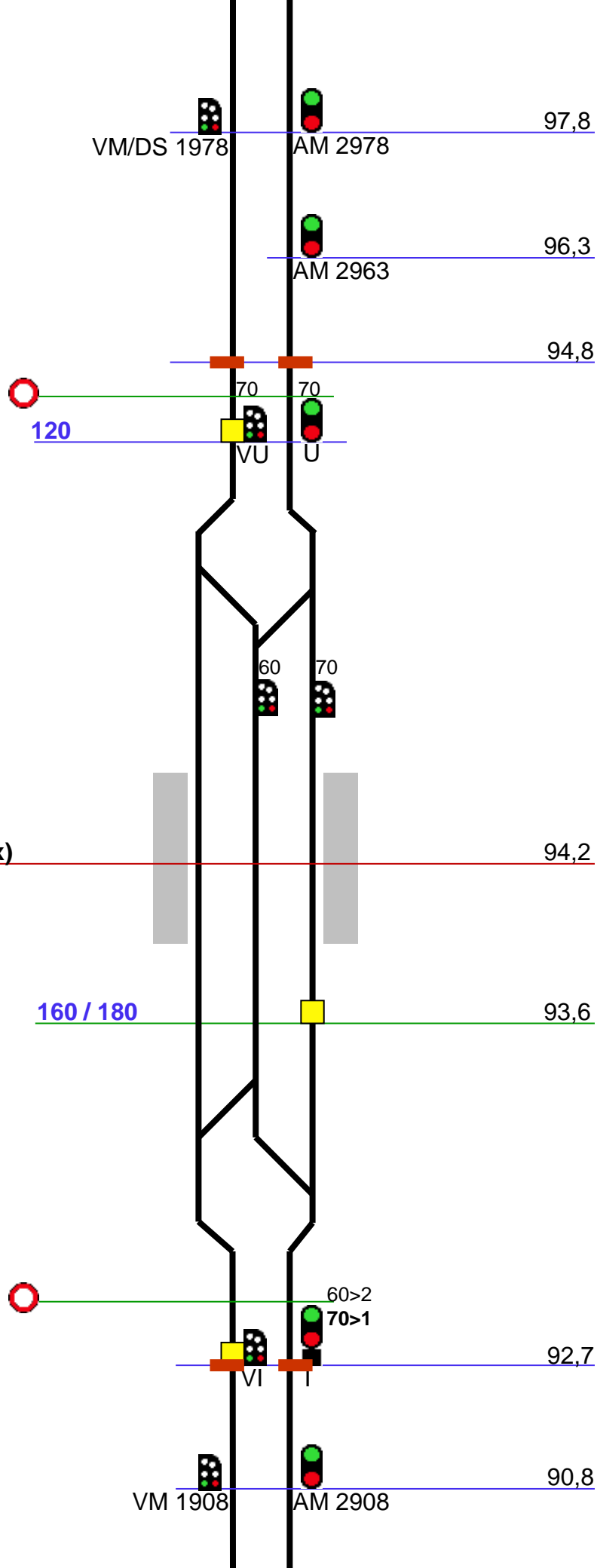

Linieblok
FC Sd

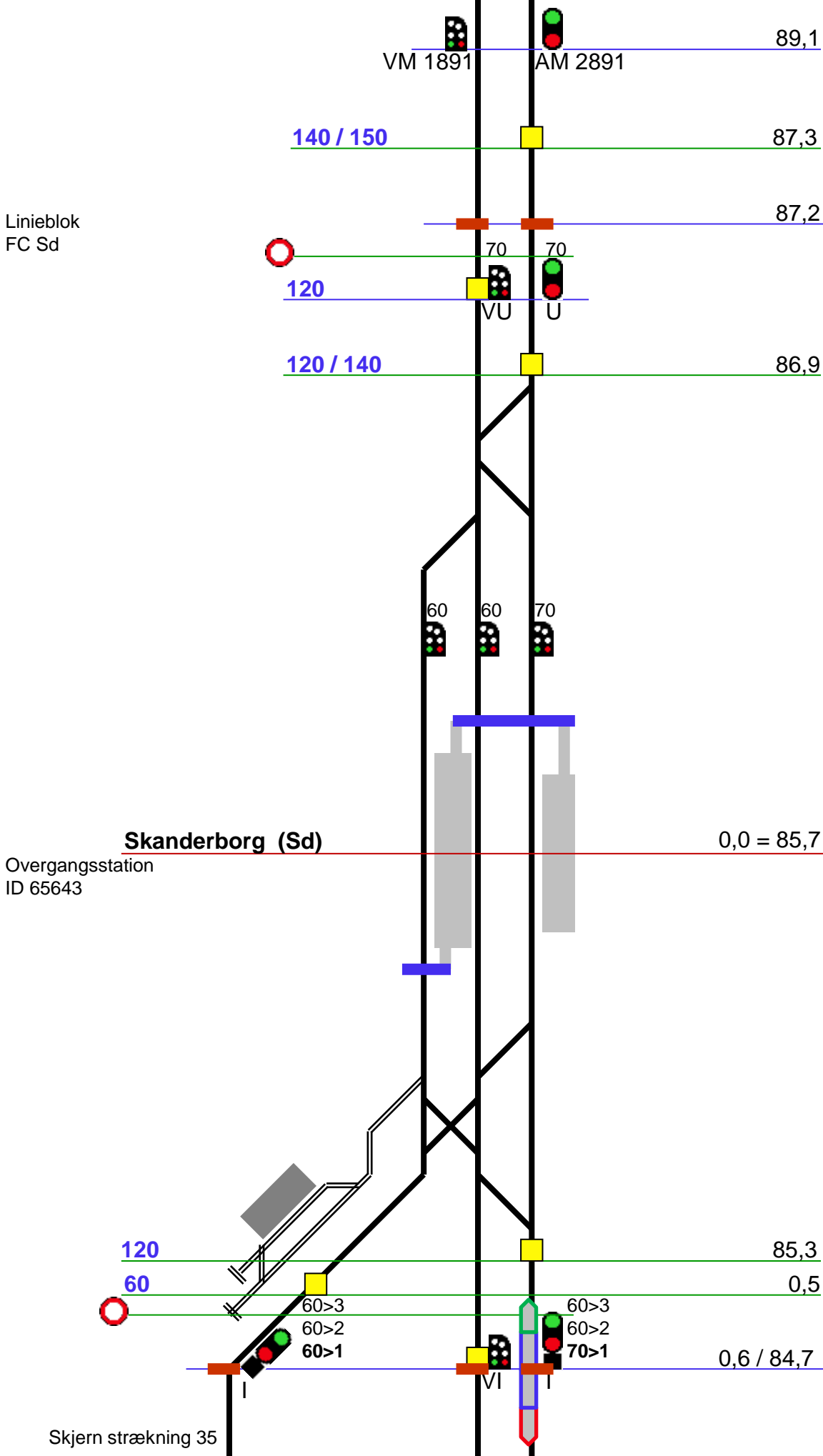

89,1

VM 1891 AM 2891

140 / 150 87,3

87,2

70 70
120 VU U

120 / 140 86,9

60 60 70

Skanderborg (Sd) 0,0 = 85,7

Overgangsstation
ID 65643

120 85,3

60 0,5

60>3 60>3
60>2 60>2
60>1 70>1

0,6 / 84,7

Skjern strækning 35

Linieblok
FC Sd

FC Sd

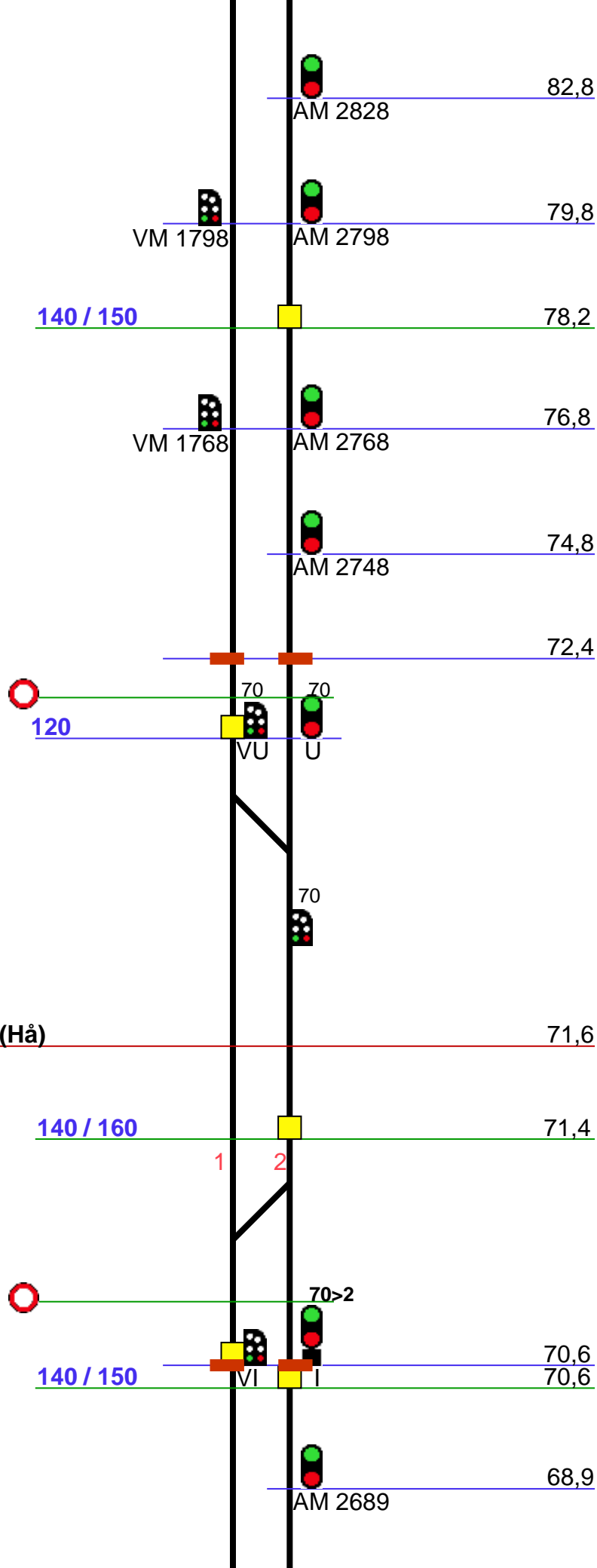

Linieblok
FC Sd

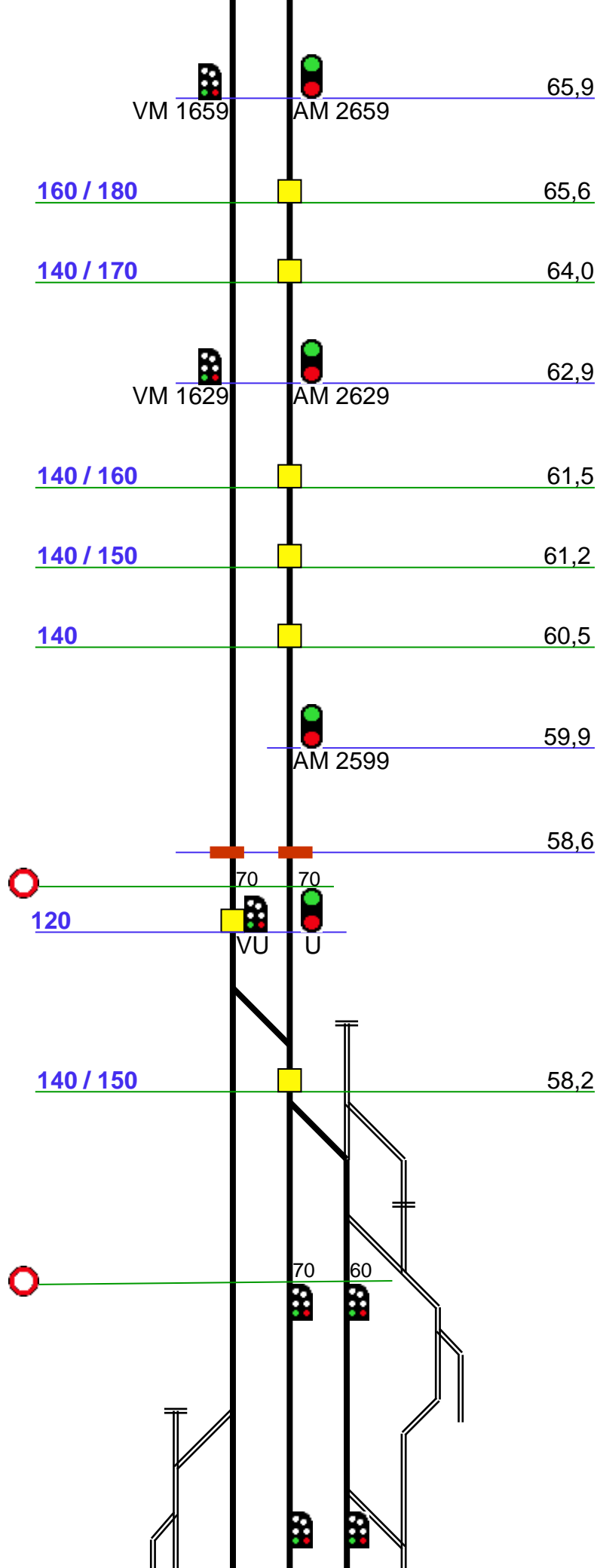

Horsens (Hs)

57,1

Overgangsstation
ID 65623

120

56,9

3 2 1



70>2
60>1

110

56,0

56,0

VI I

140 / 150

55,1

54,3

AM 2543

140 / 160

51,5

AM 2515

160

51,0

49,0

AM 2490

46,5

AM 2465

43,5

AM 2435

41,8

FC Sd

Hedensted (Hed)

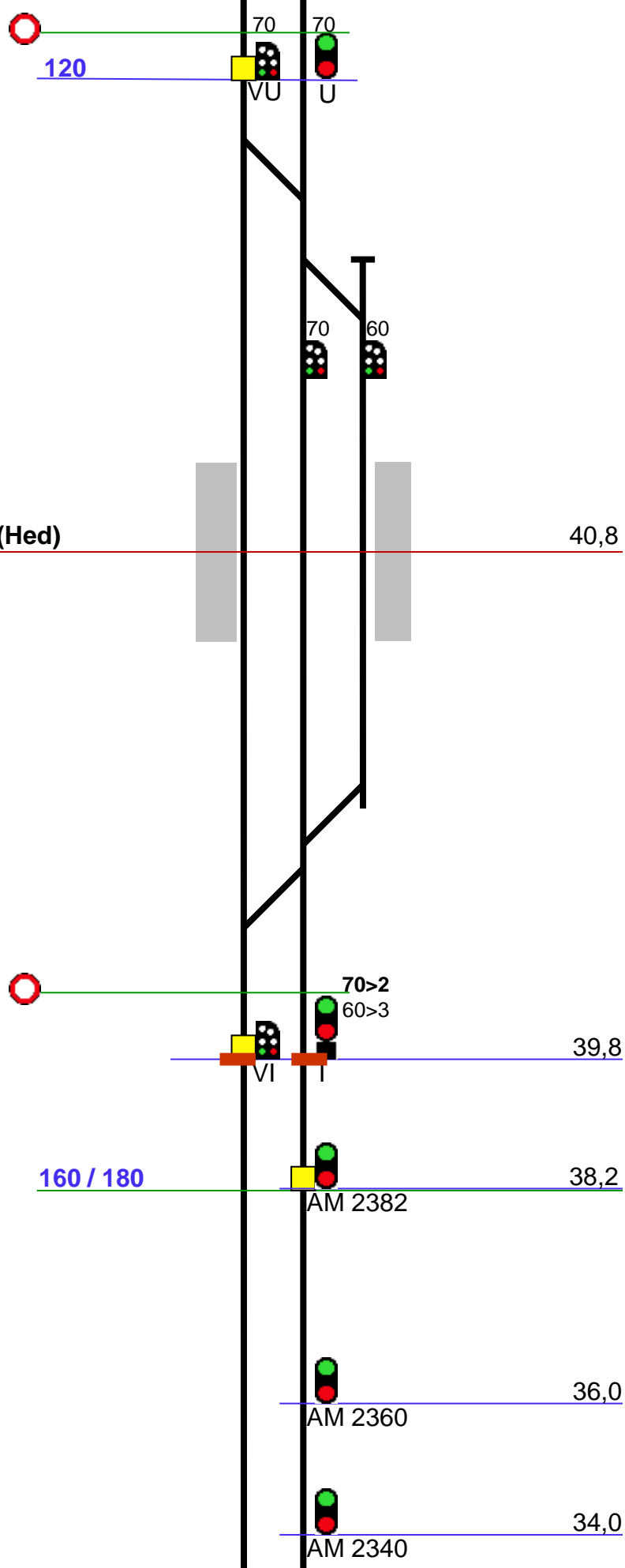

Holstebro strækning 33

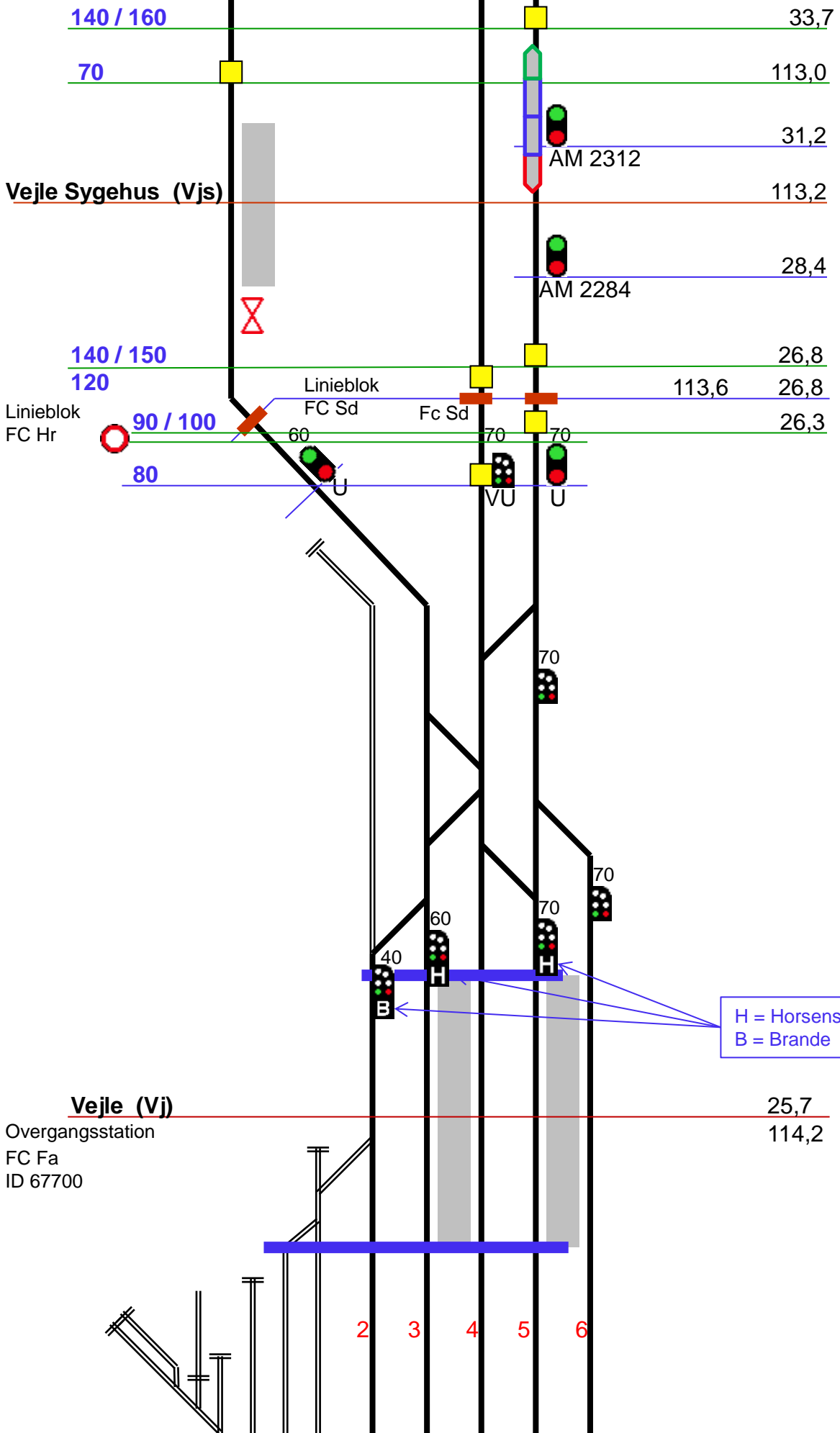

H = Horsens
B = Brande

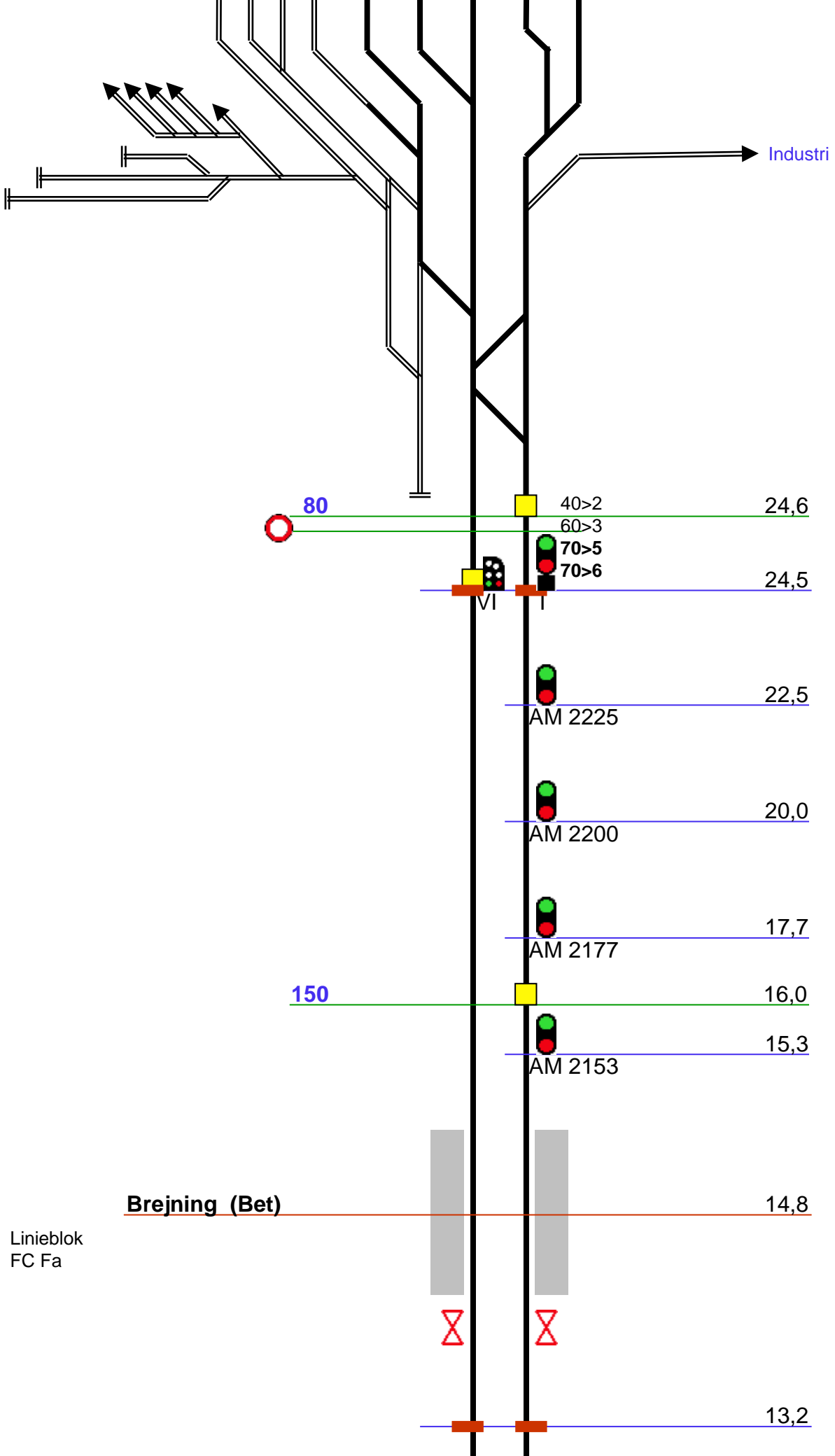

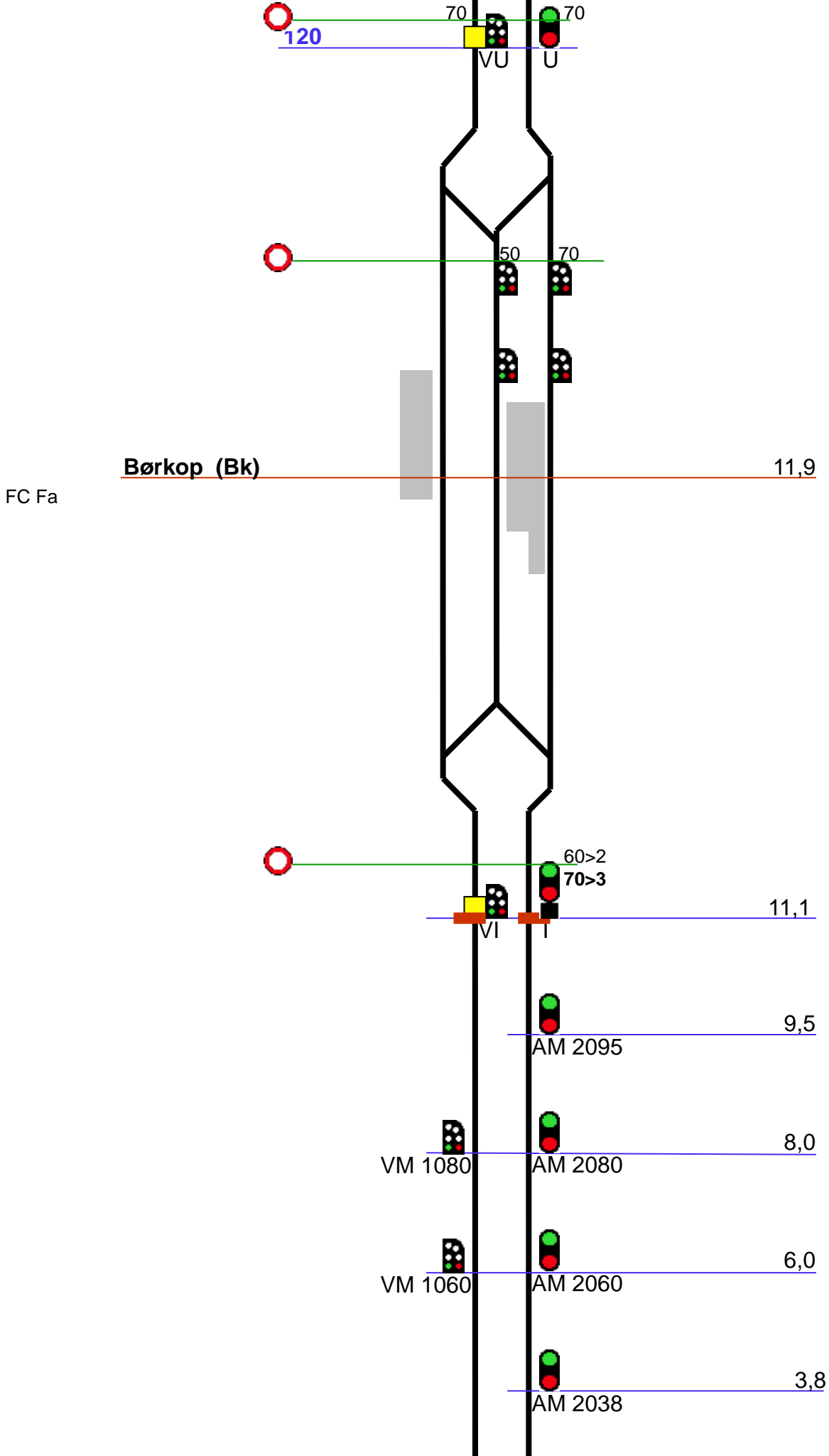

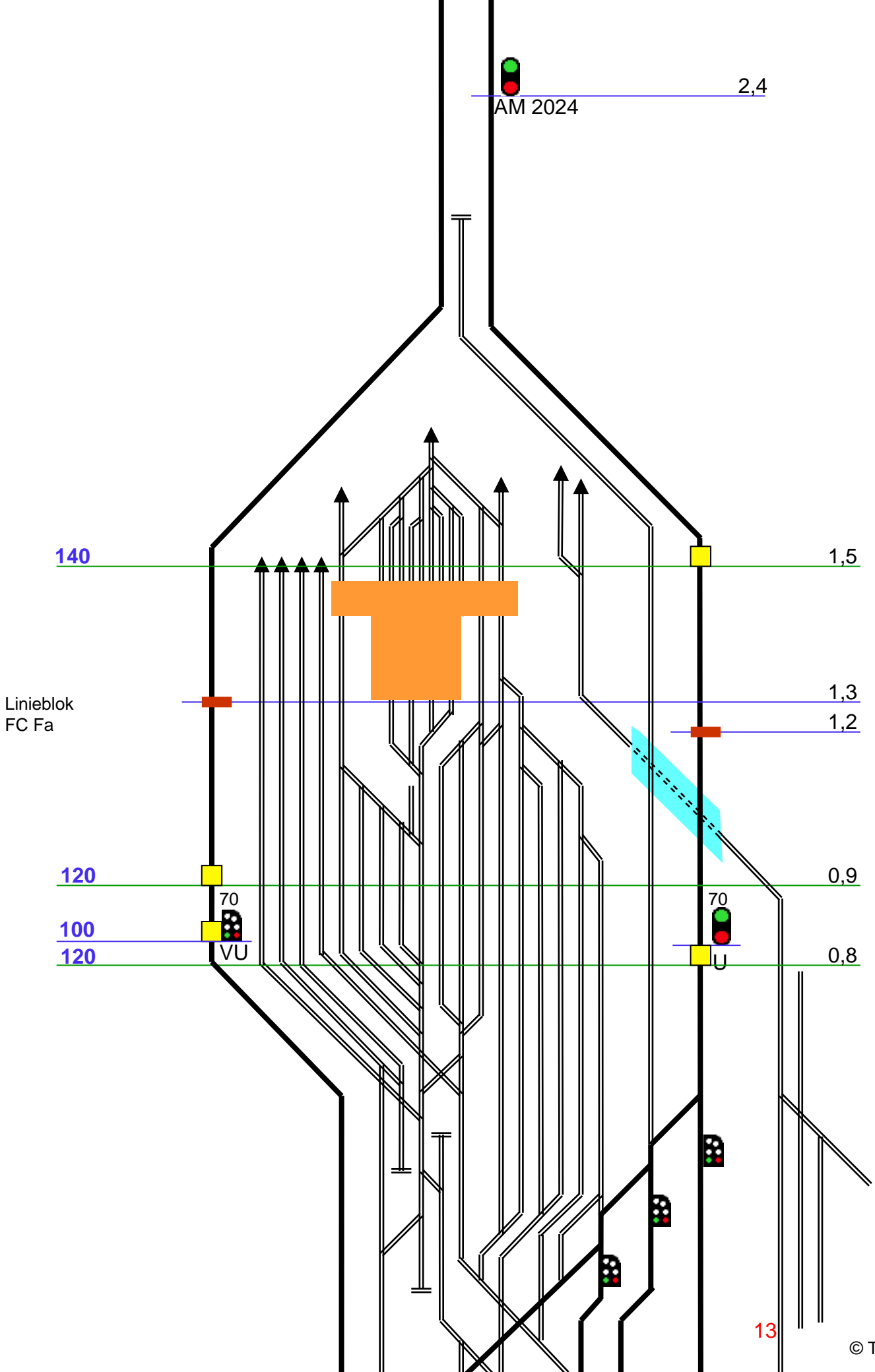

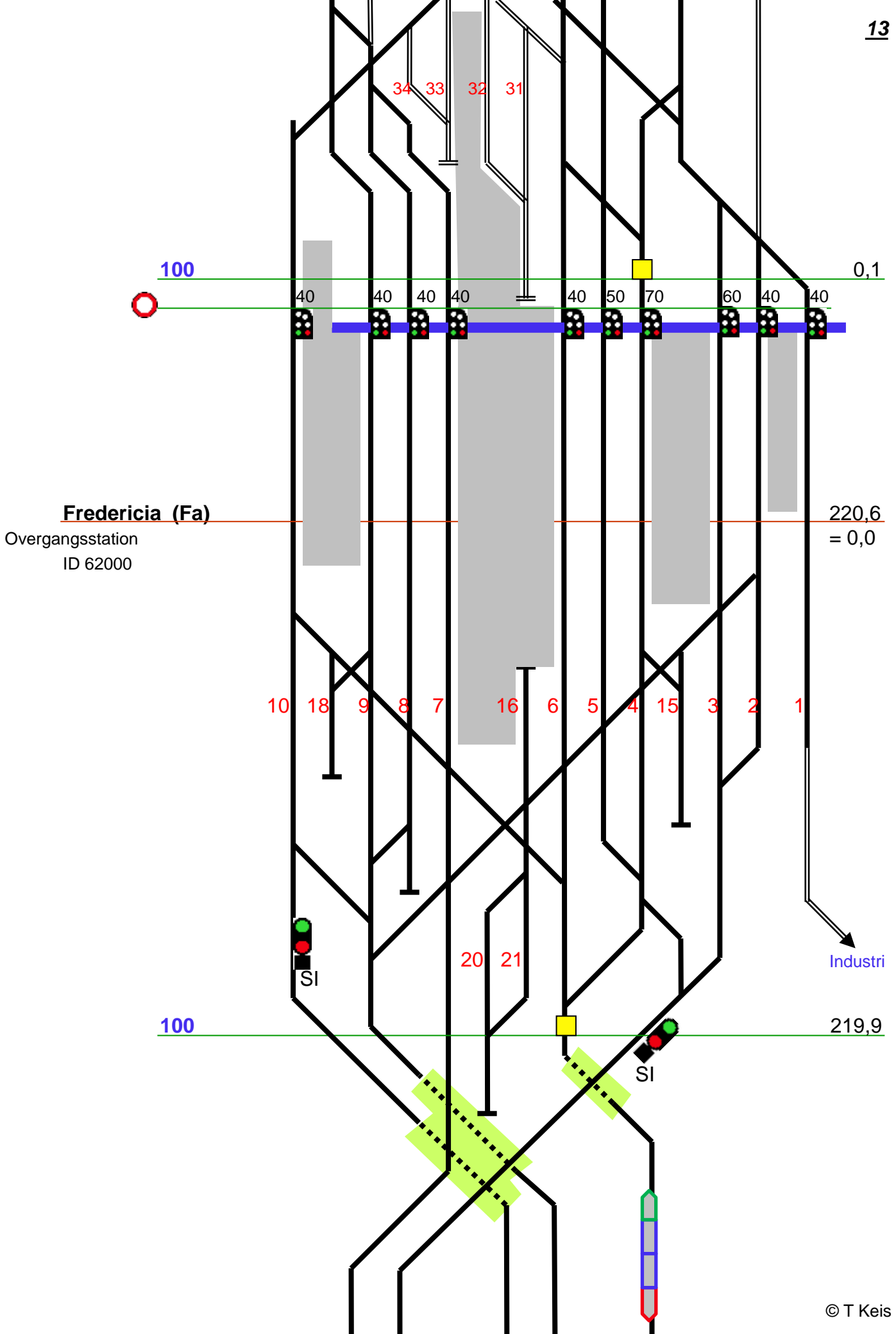

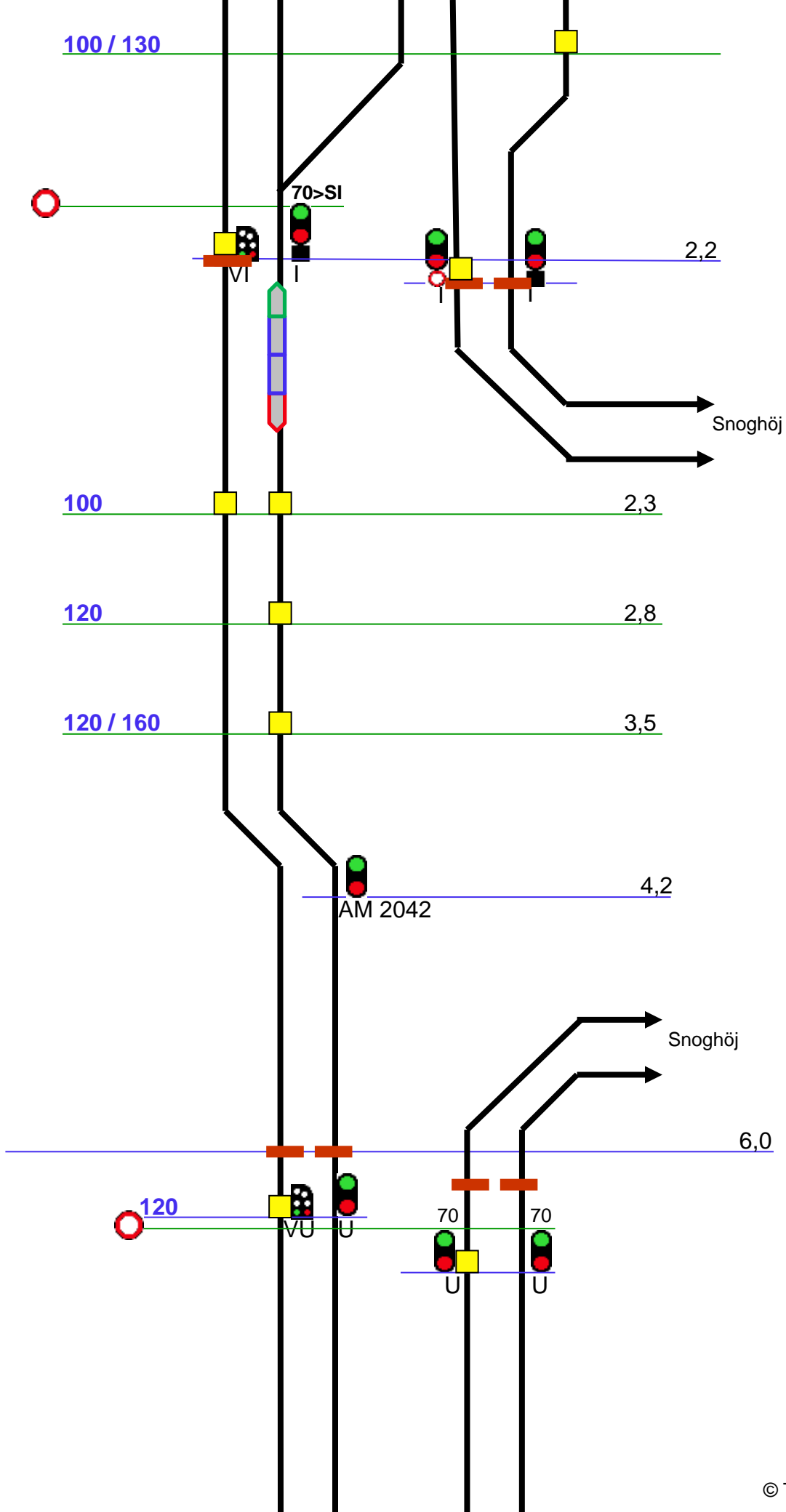

Linieblok
FC Fa

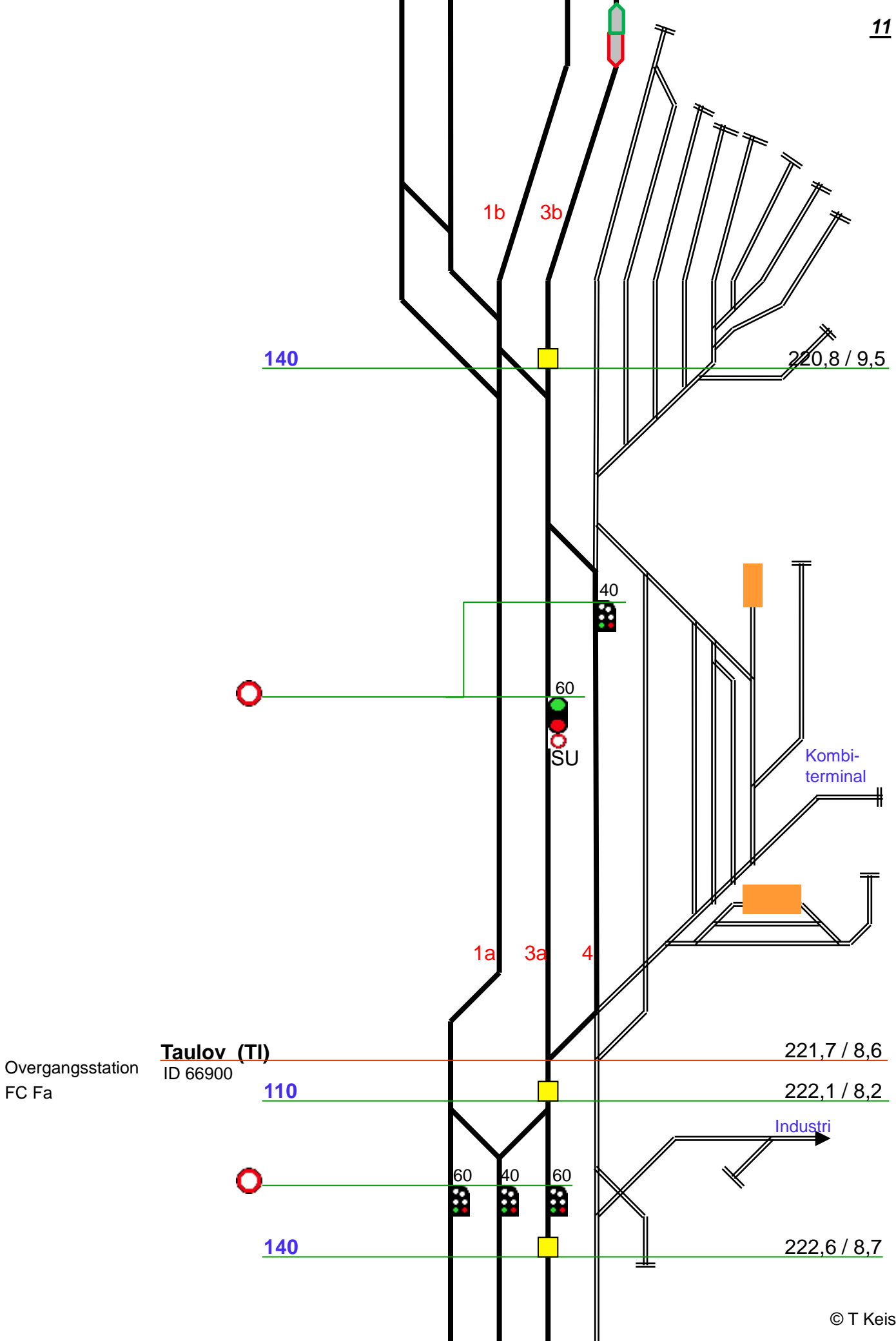

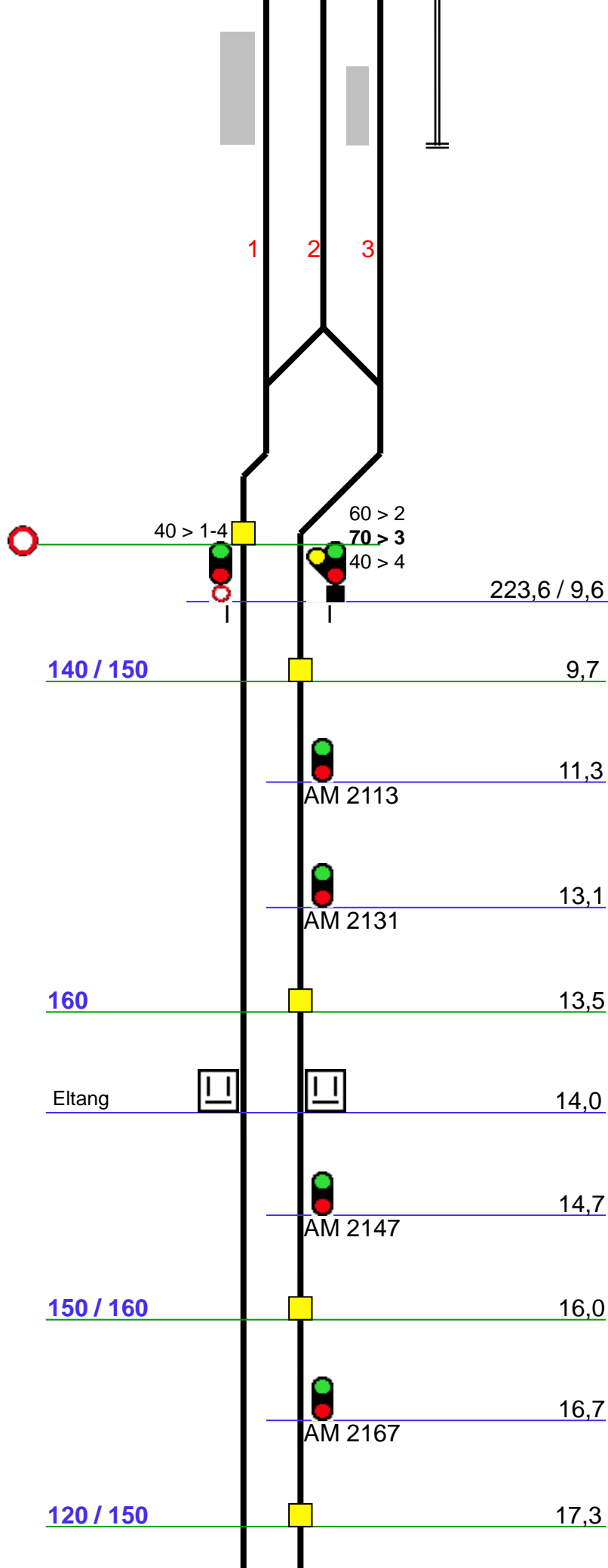

Linieblok
FC Fa

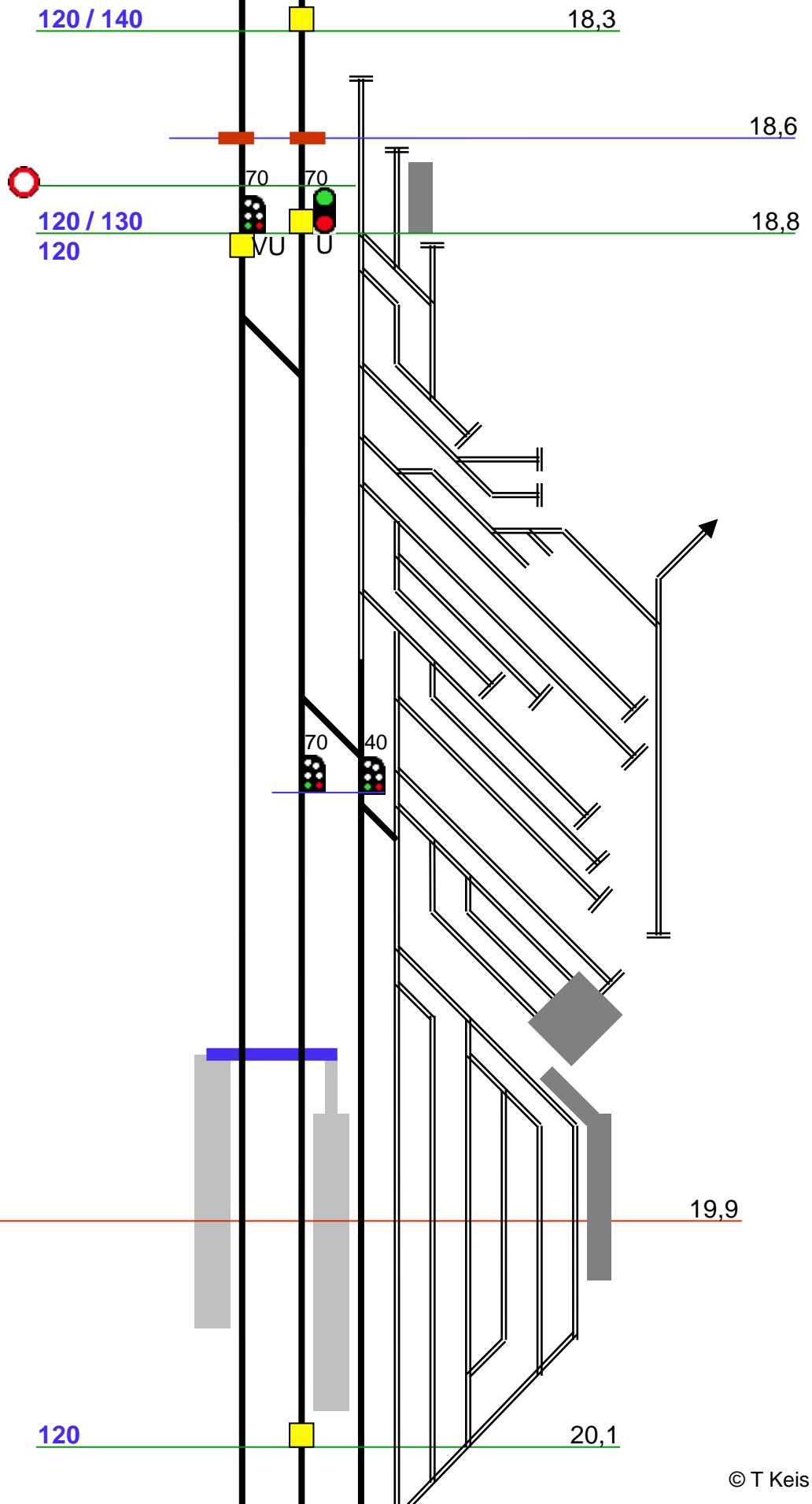

120 / 140

18,3

18,6

120 / 130
120

18,8

70

70

VU

U

70

40

Kolding (Kd)

FC Fa
ID 62027

19,9

120

20,1

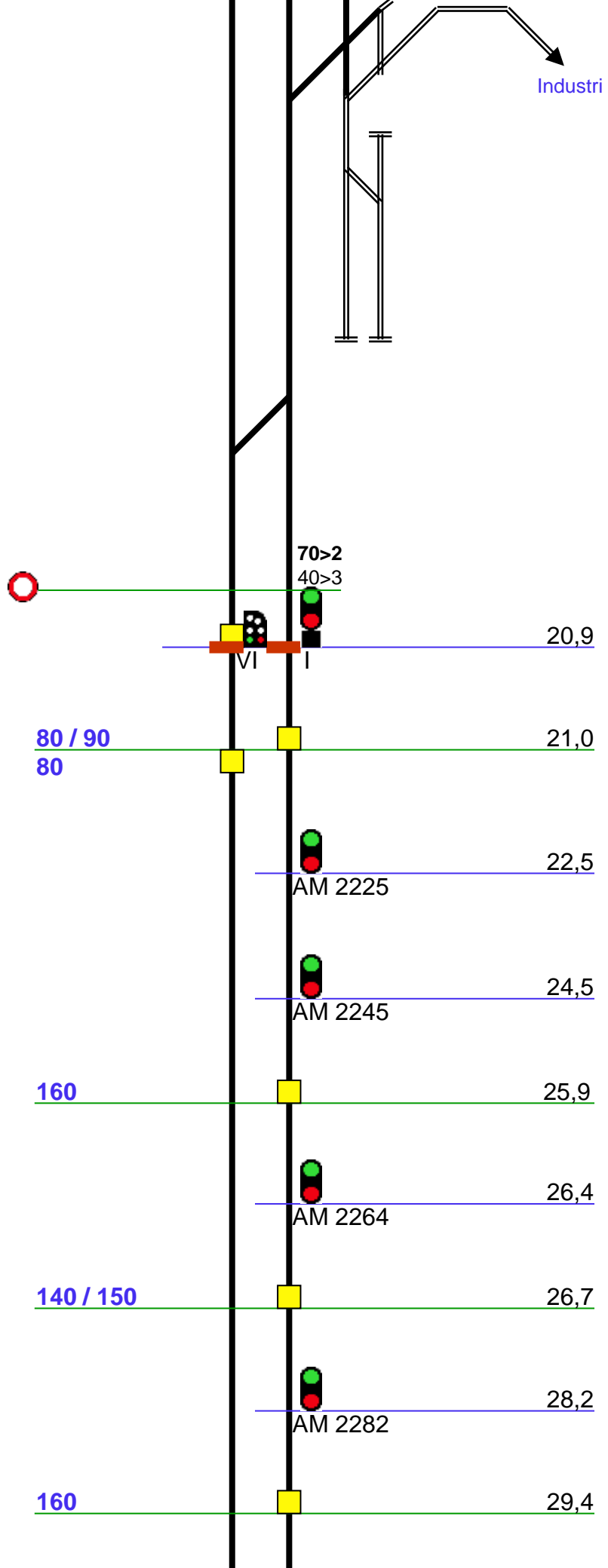

Linieblok
FC Fa

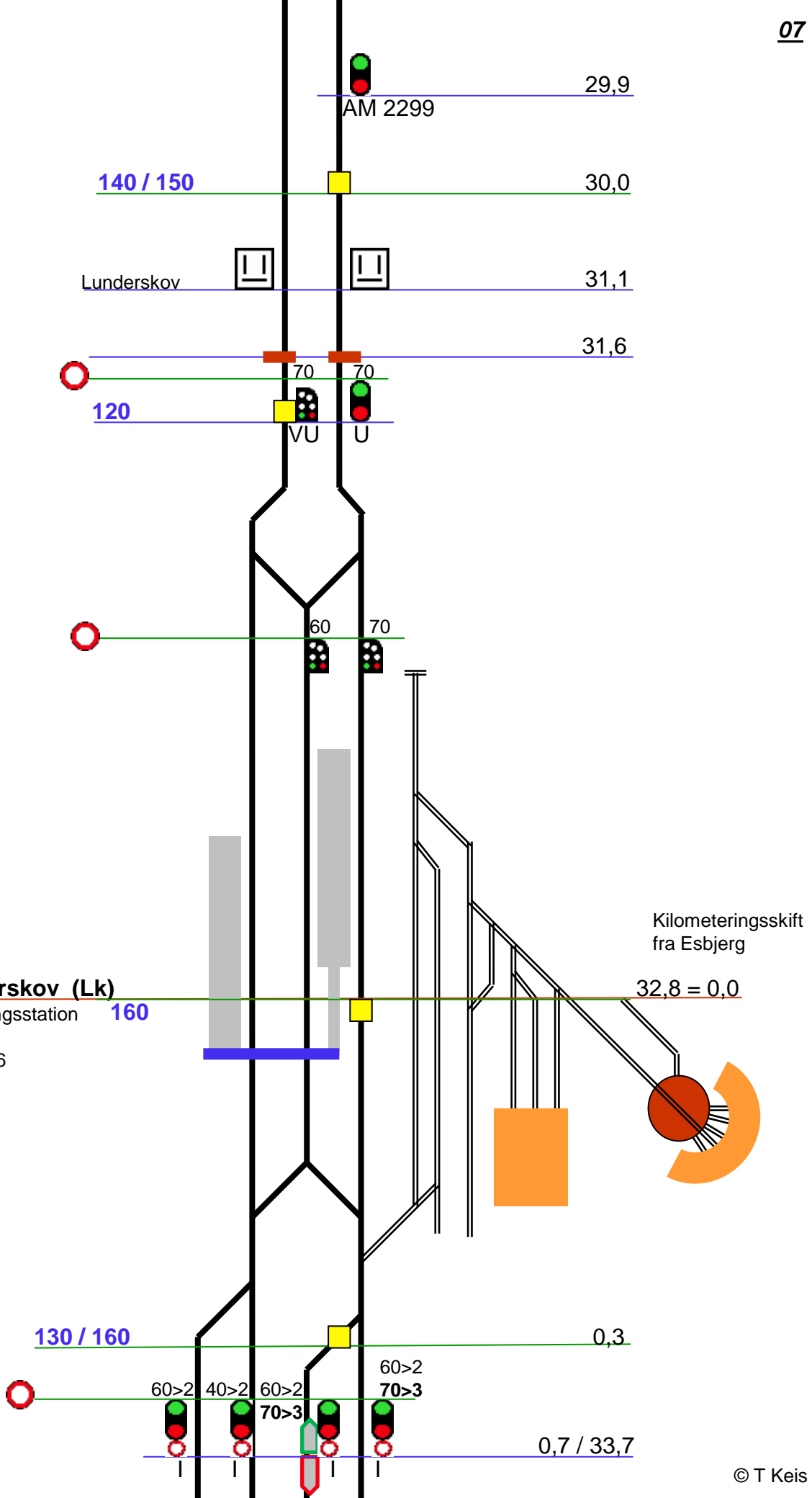

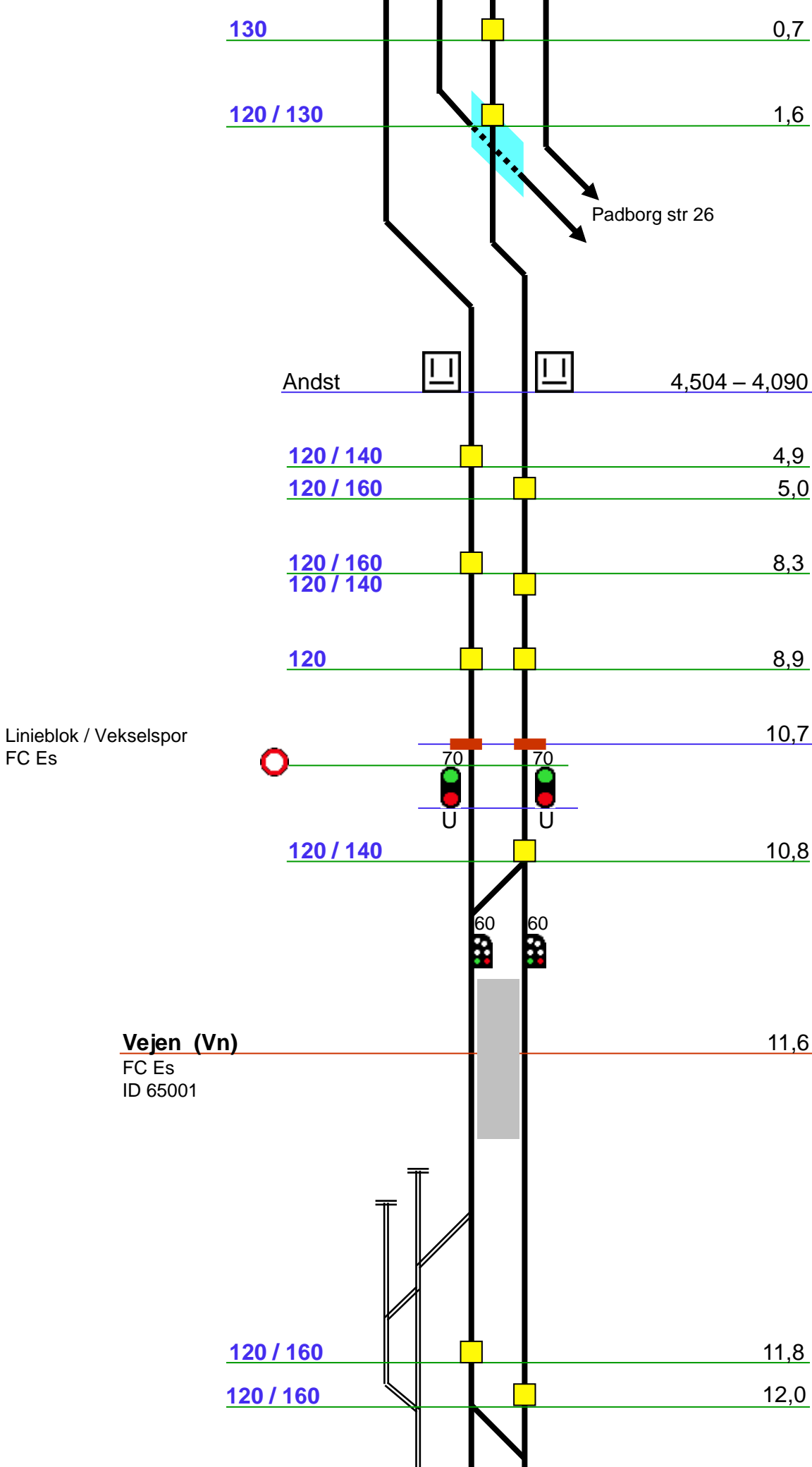

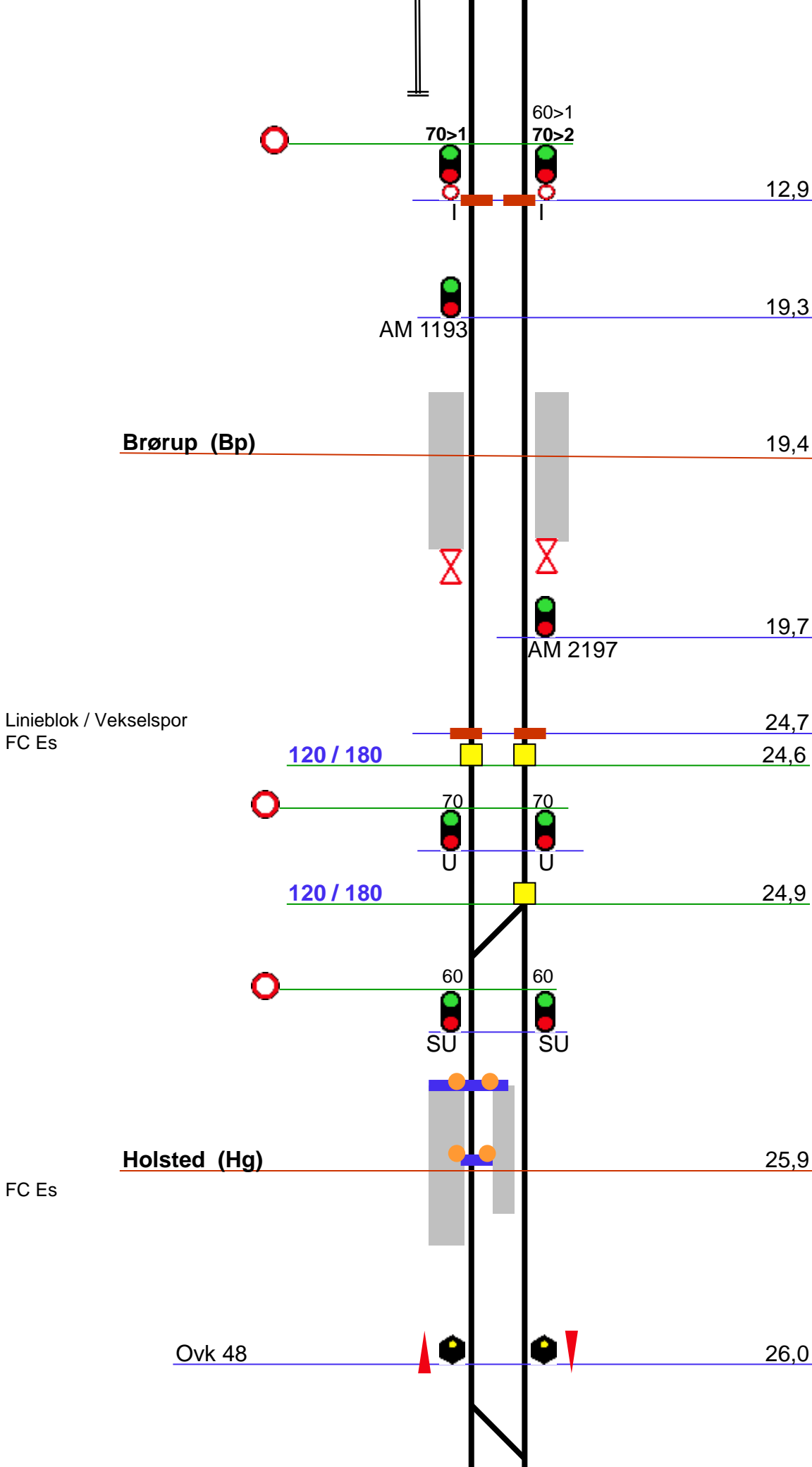

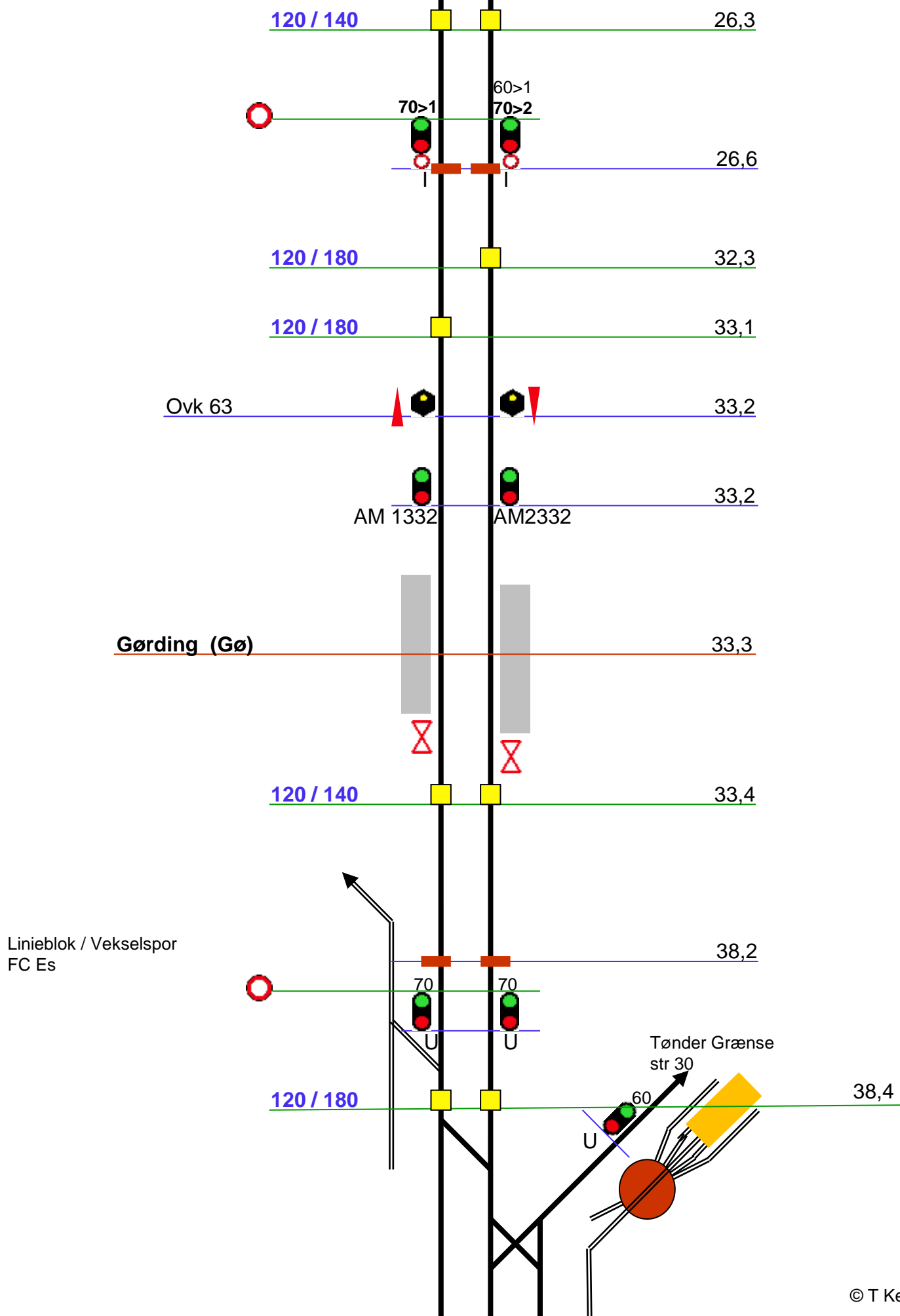

Bramming (Bm)

Overgangsstation
FC Es
ID 65041

L = Lunderskov
R = Ribe

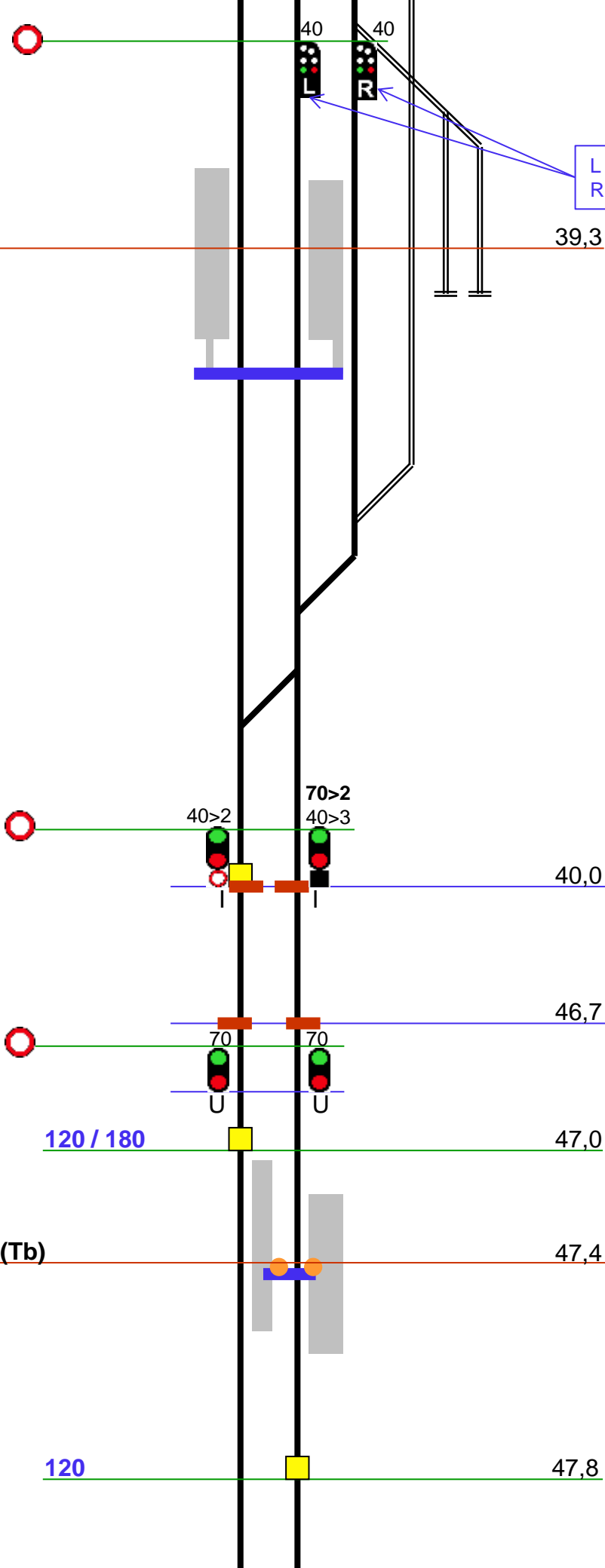

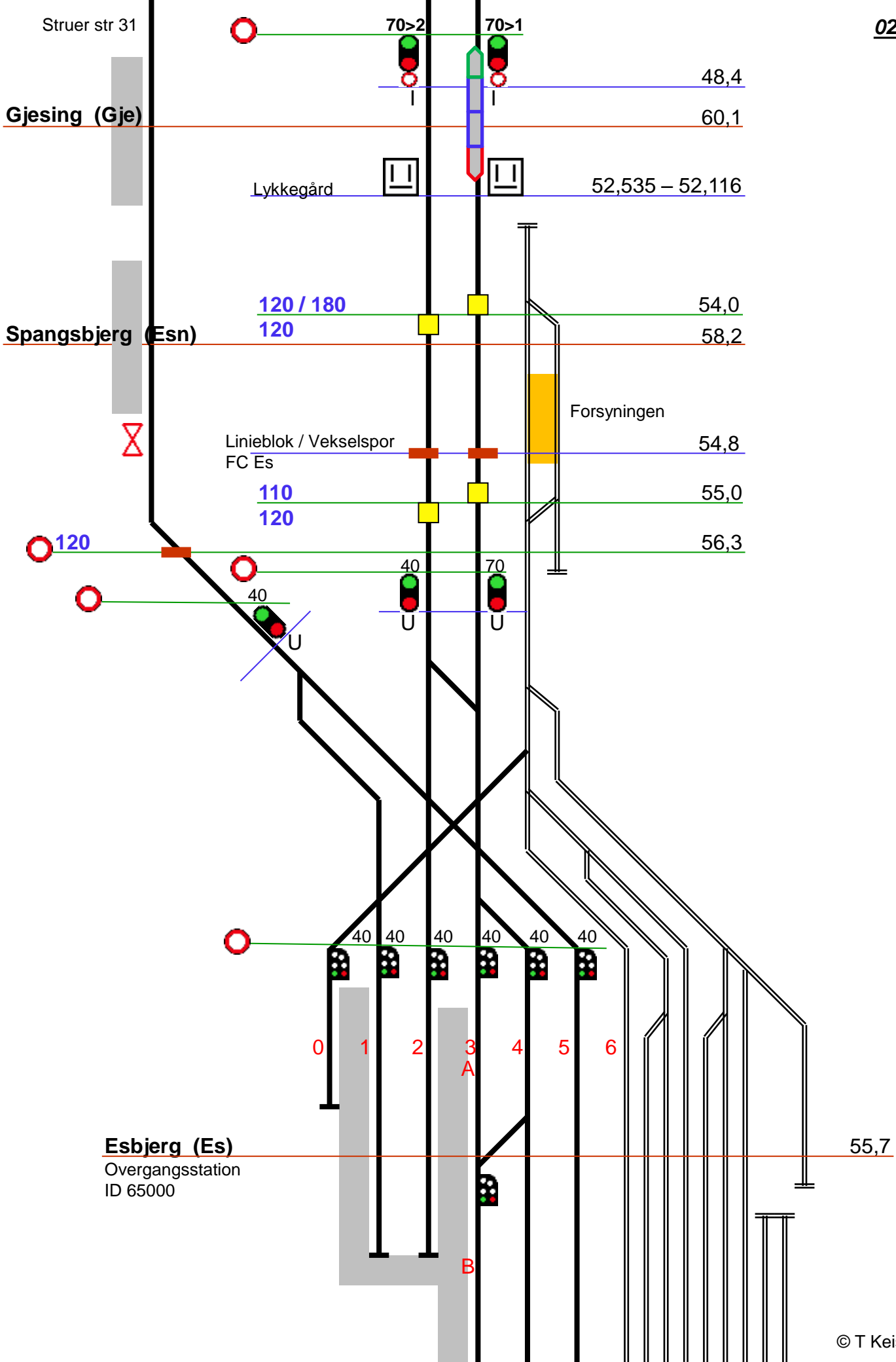

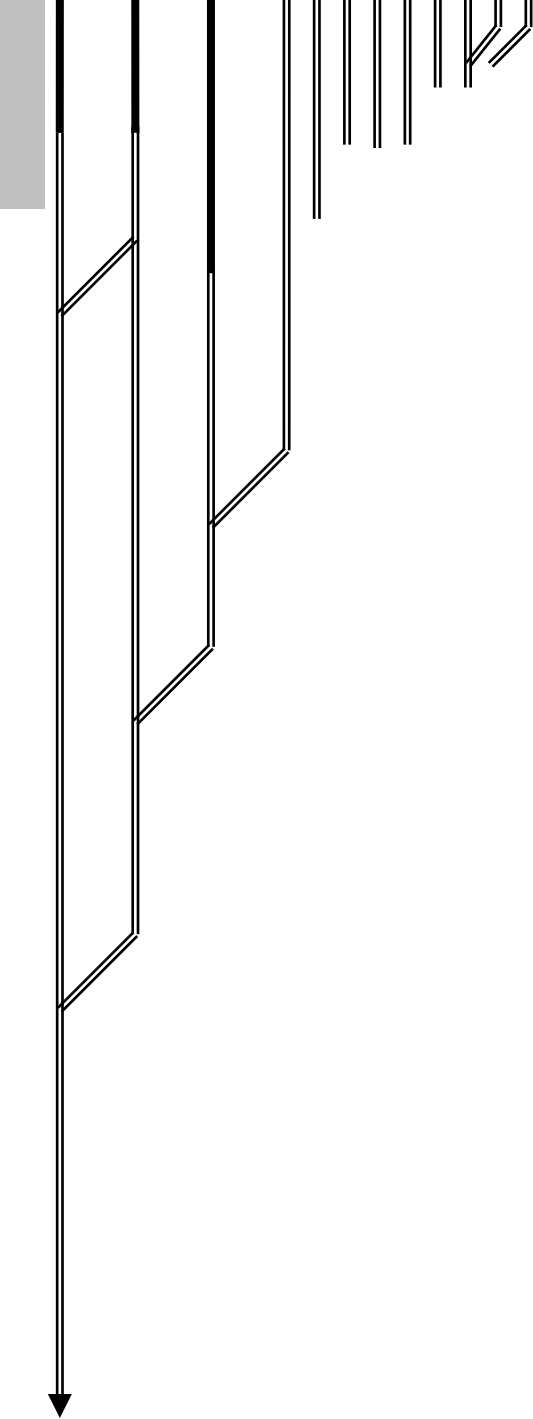

Havnen