

Stockholm S 780m

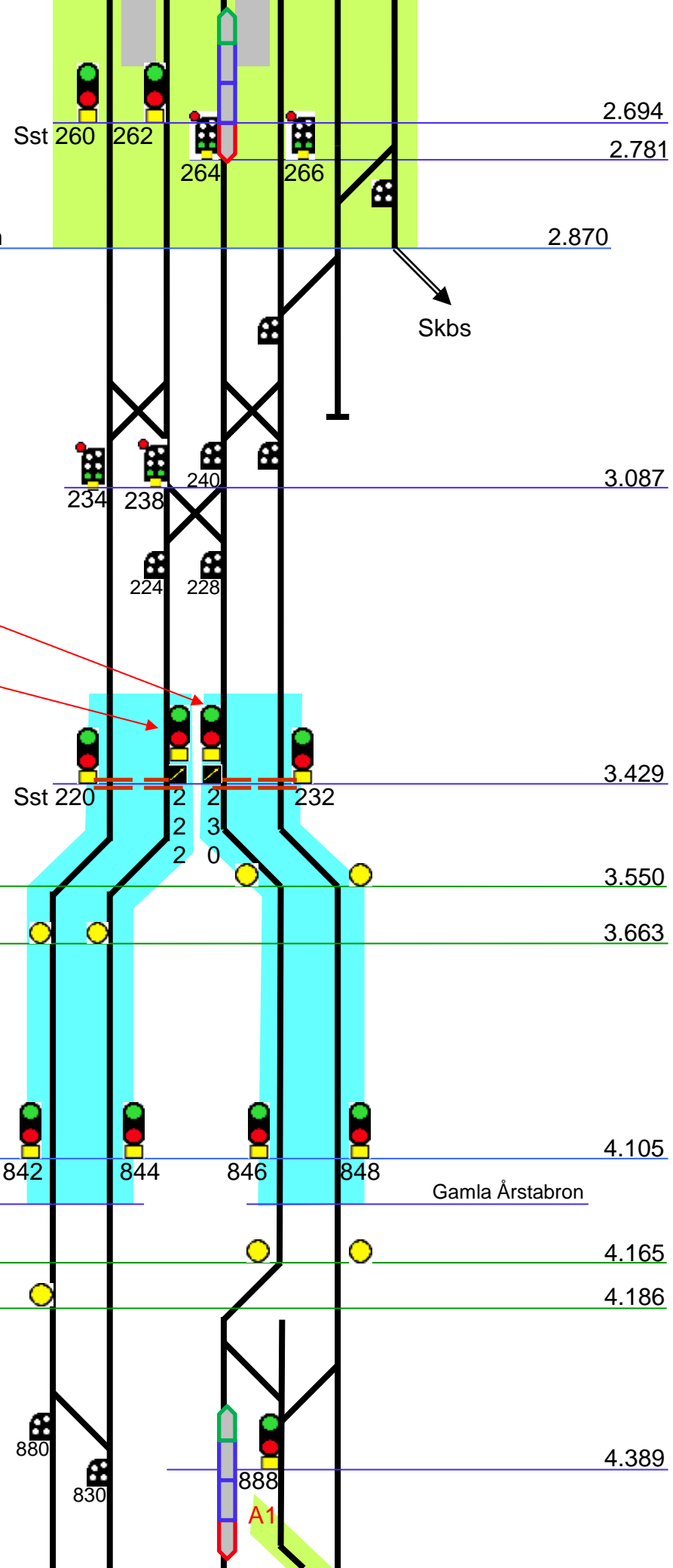

Gul cirkel mot Sci
Släckt mot Cst

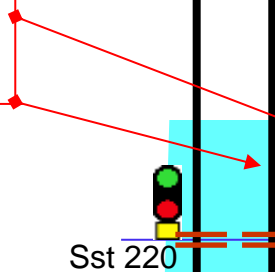

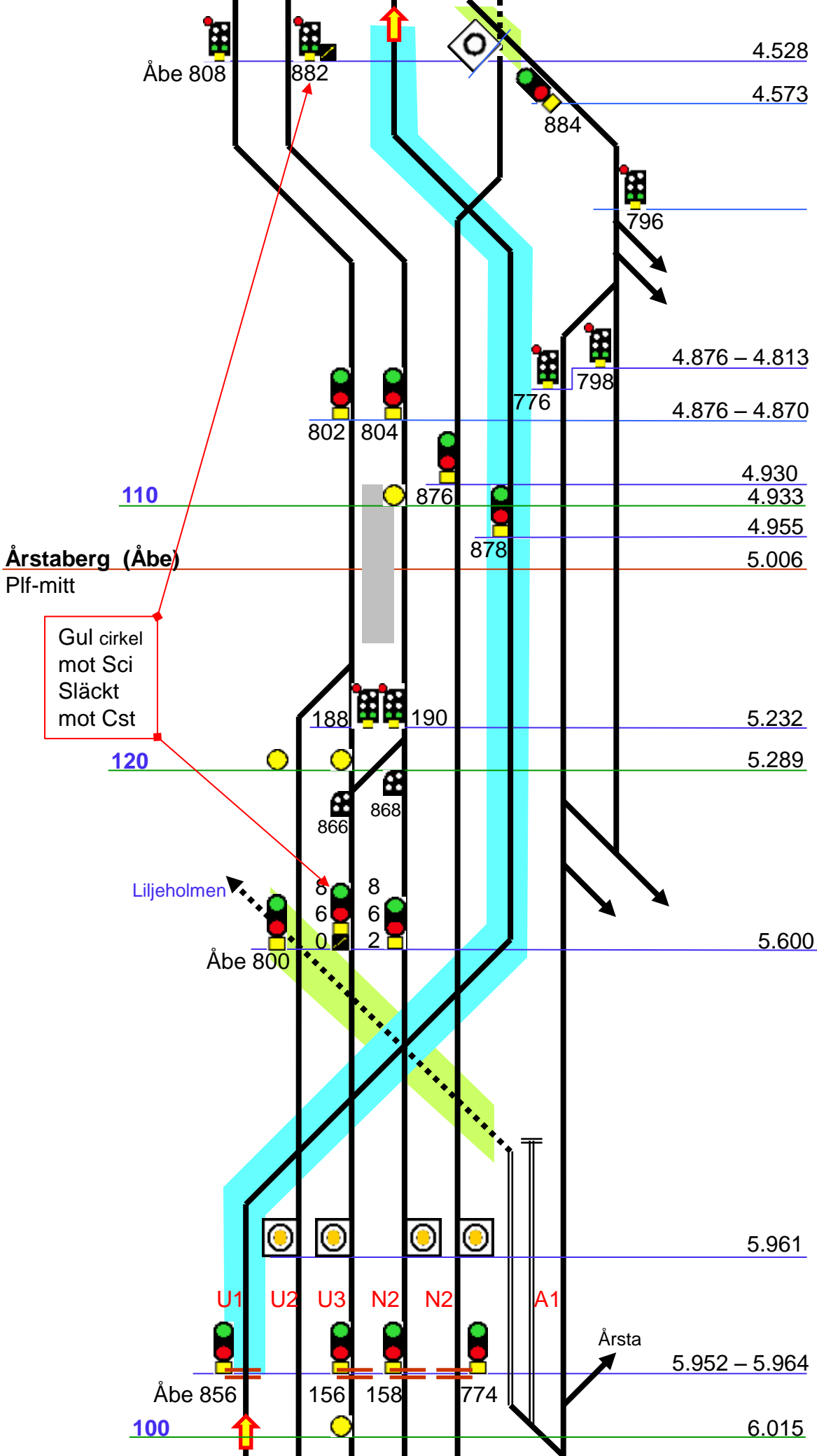

Gul cirkel
mot Sci
Släckt
mot Cst

Årstaberg (Åbe)
Plf-mitt

Liljeholmen

Årsta

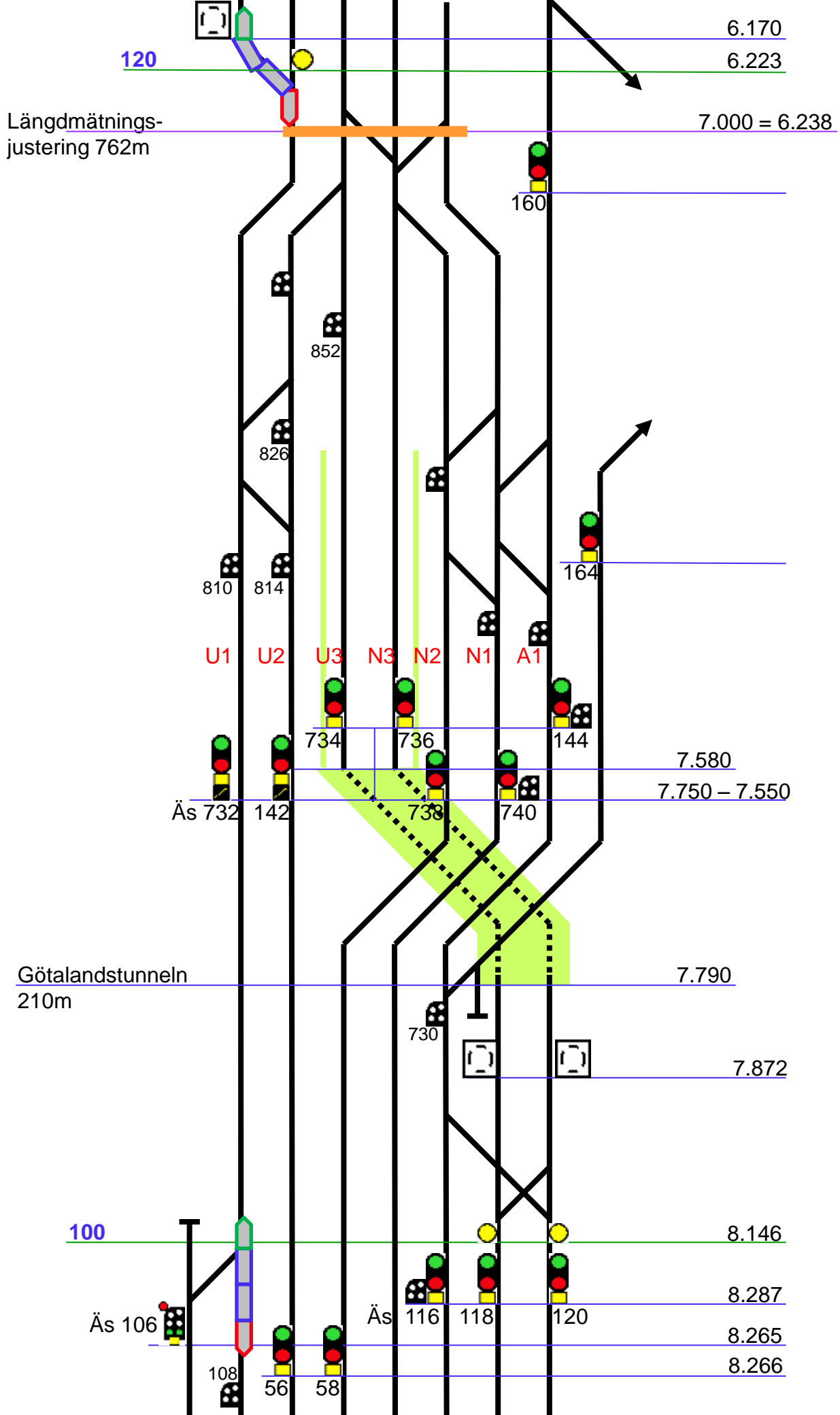

Älvsjö (Äs)

55.480 =
8.380

Spår 1 2 3 4 5 6 7 8

100

55.350

Äs 114

44

50

126

92

Högdalen

8.830

84

82

720

40

042

722

134

718

26

28

1 2 3 4 5 6 7 8 9

Älvsjöhallen

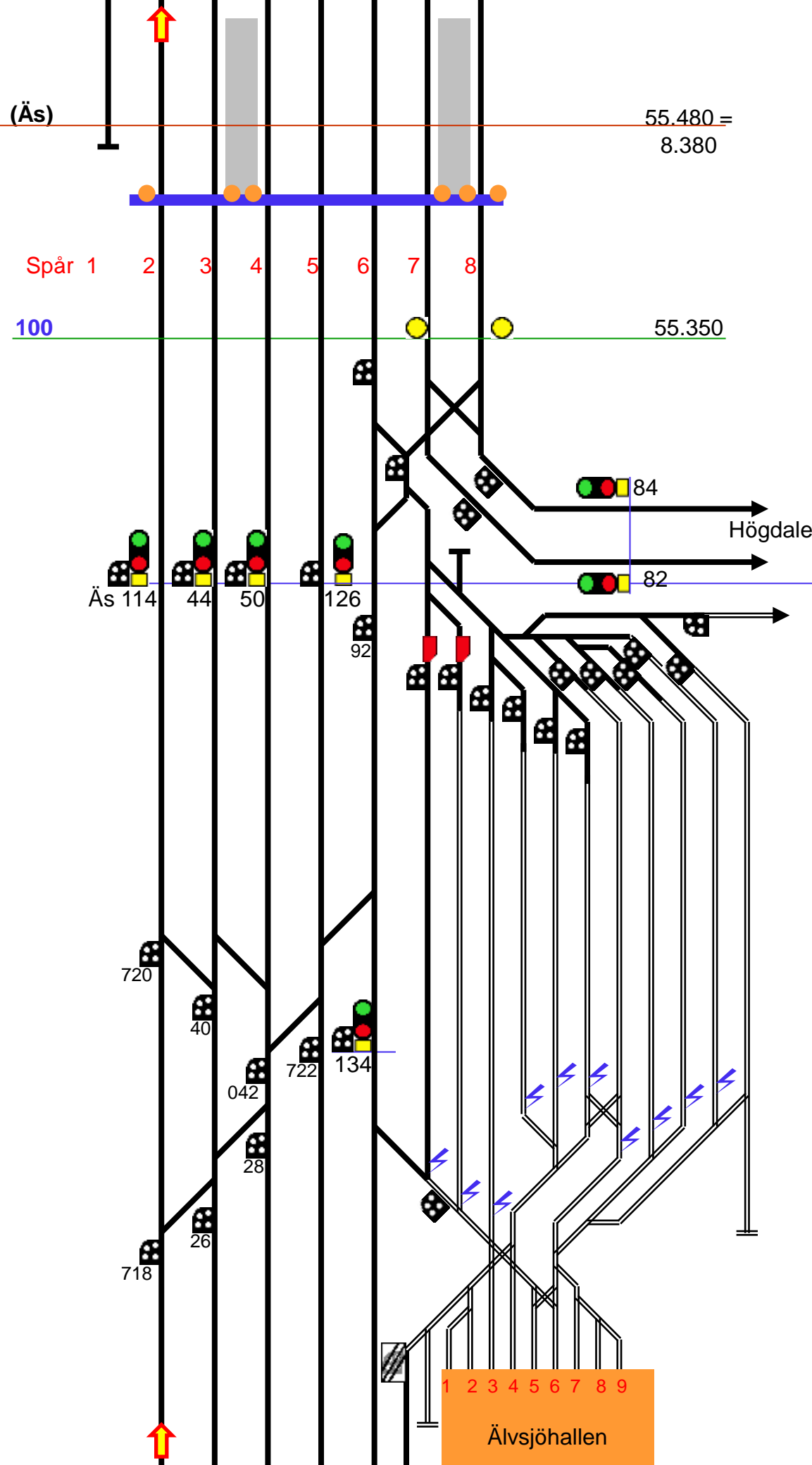

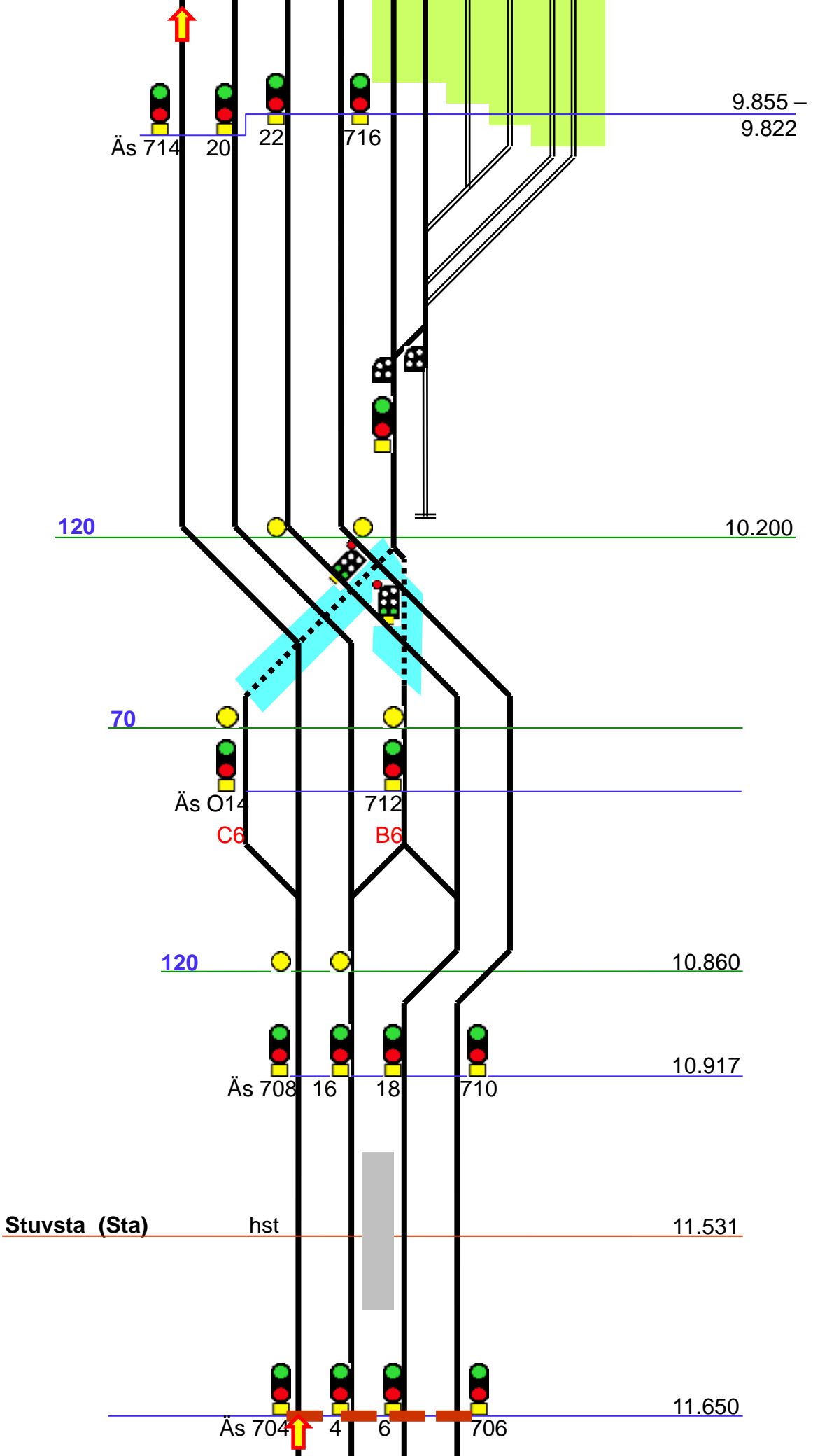

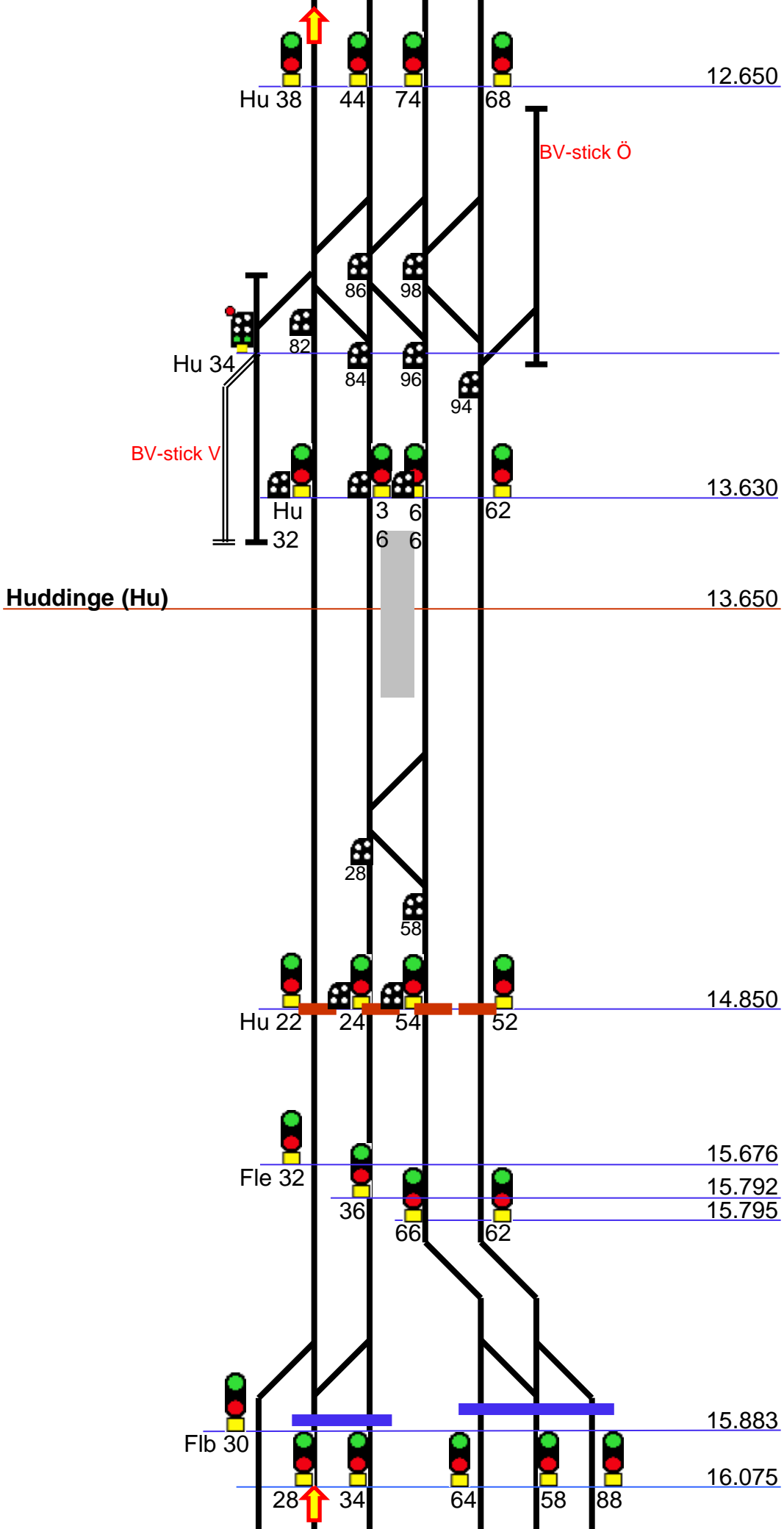

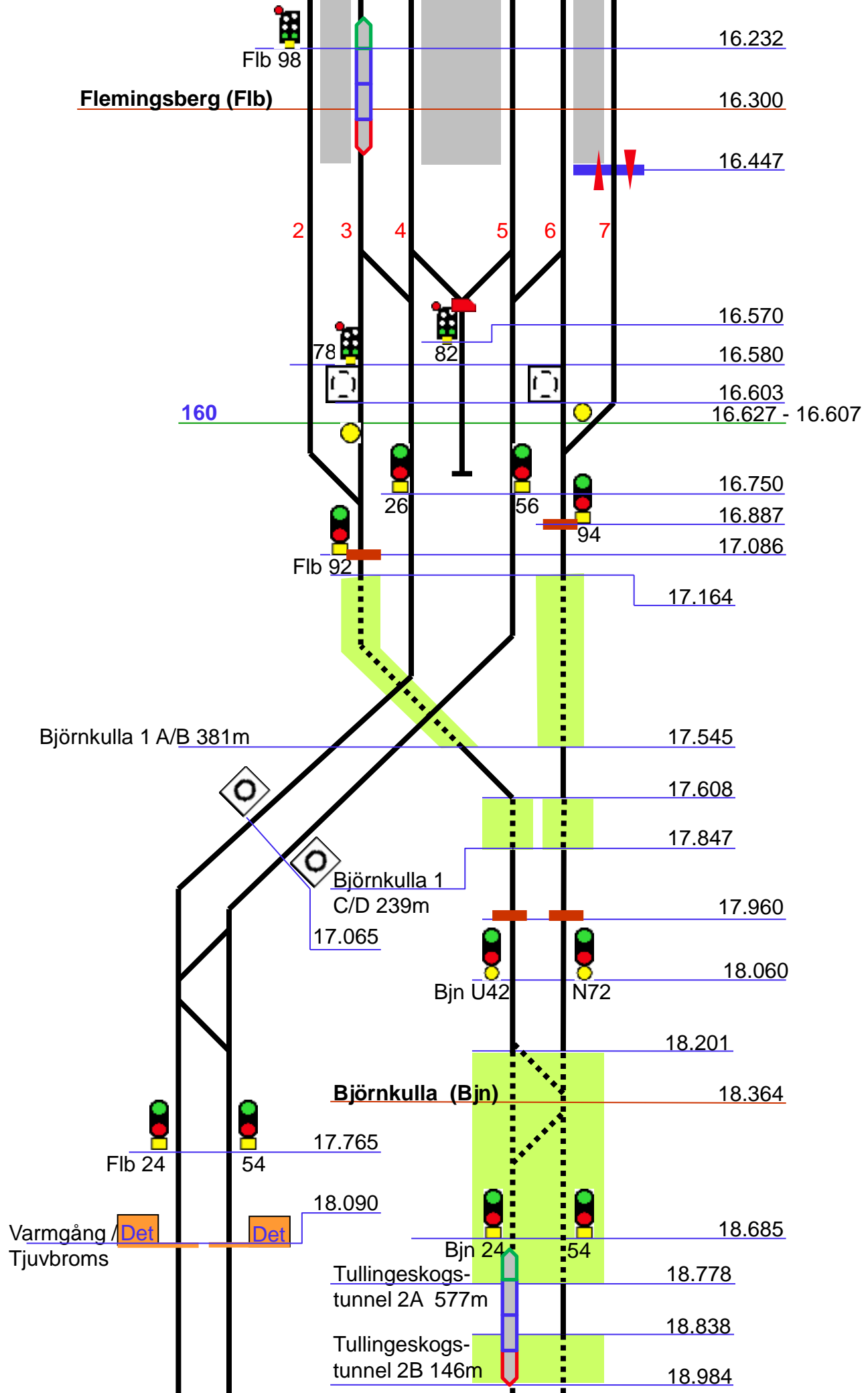

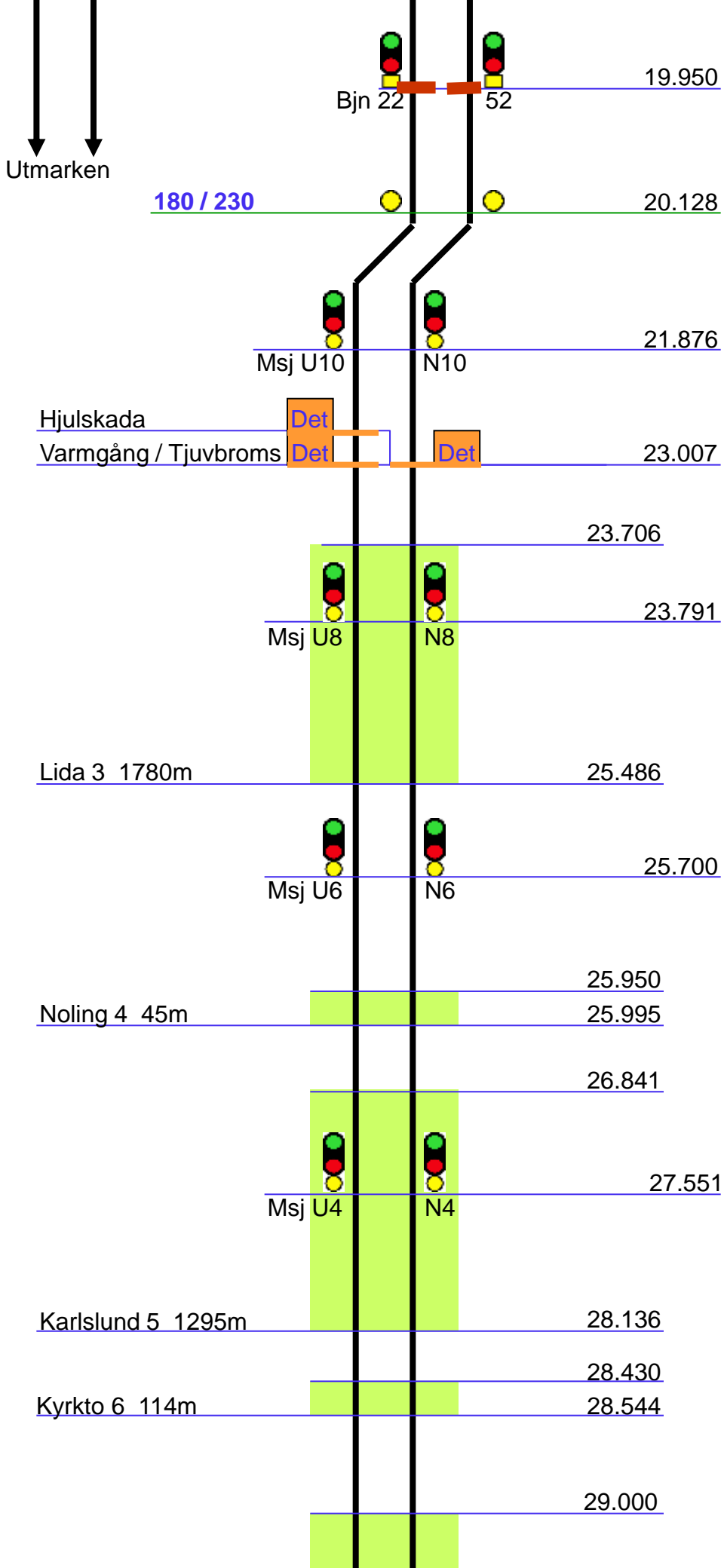

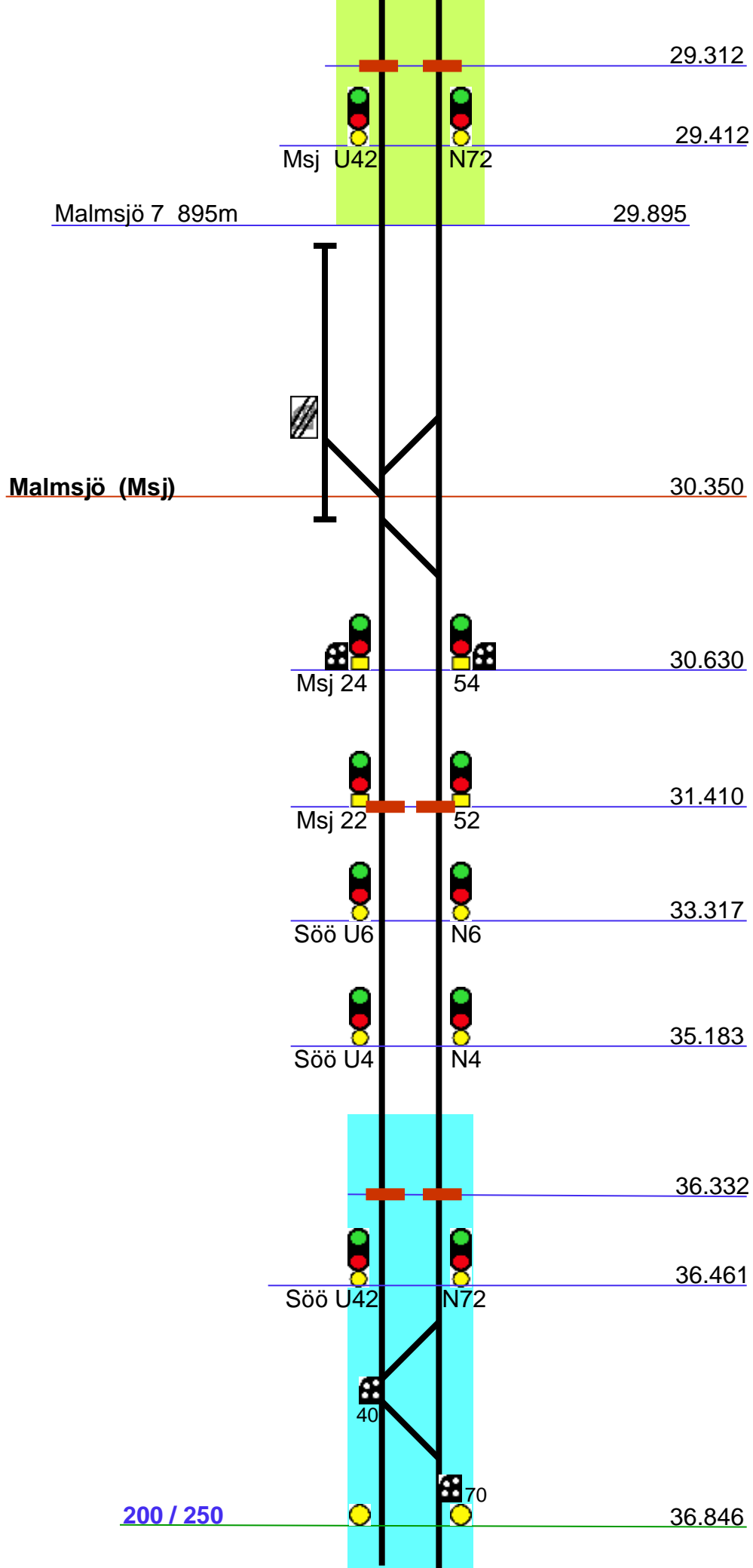

Mot
Södertälje hamn

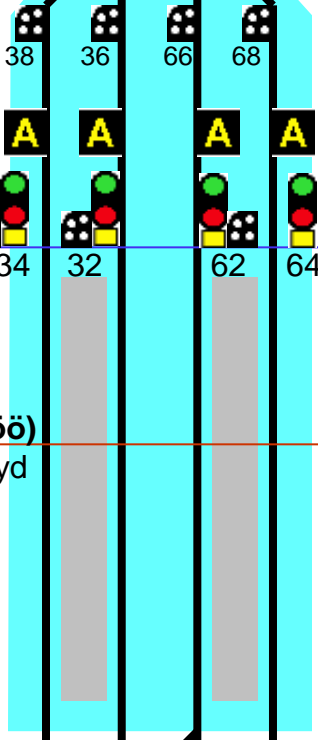

Söö 34 32 62 64 37.226

(1.819) **Södertälje Syd Övre (Söö)** 37.404
Annonseras Södertälje Syd

5 6 7 8

140 / 180 37.925

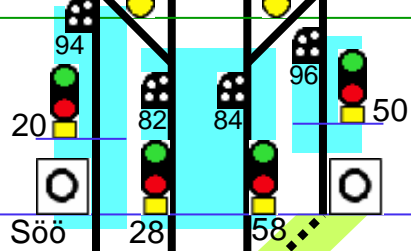

Söö 20 28 58 50 38.097

L44 3.375

14 3.242

16 3.250 3.358 Söö 26 56 38.898

130 3.358

Tveta 93m 3.450 3.543 Kvedesta-tunnel 8A 52m 39.232 39.284

160 3.633 39.357

Stockholms DLO Söö 12 4.061 Kvedesta-tunnel 8B 377m 39.734



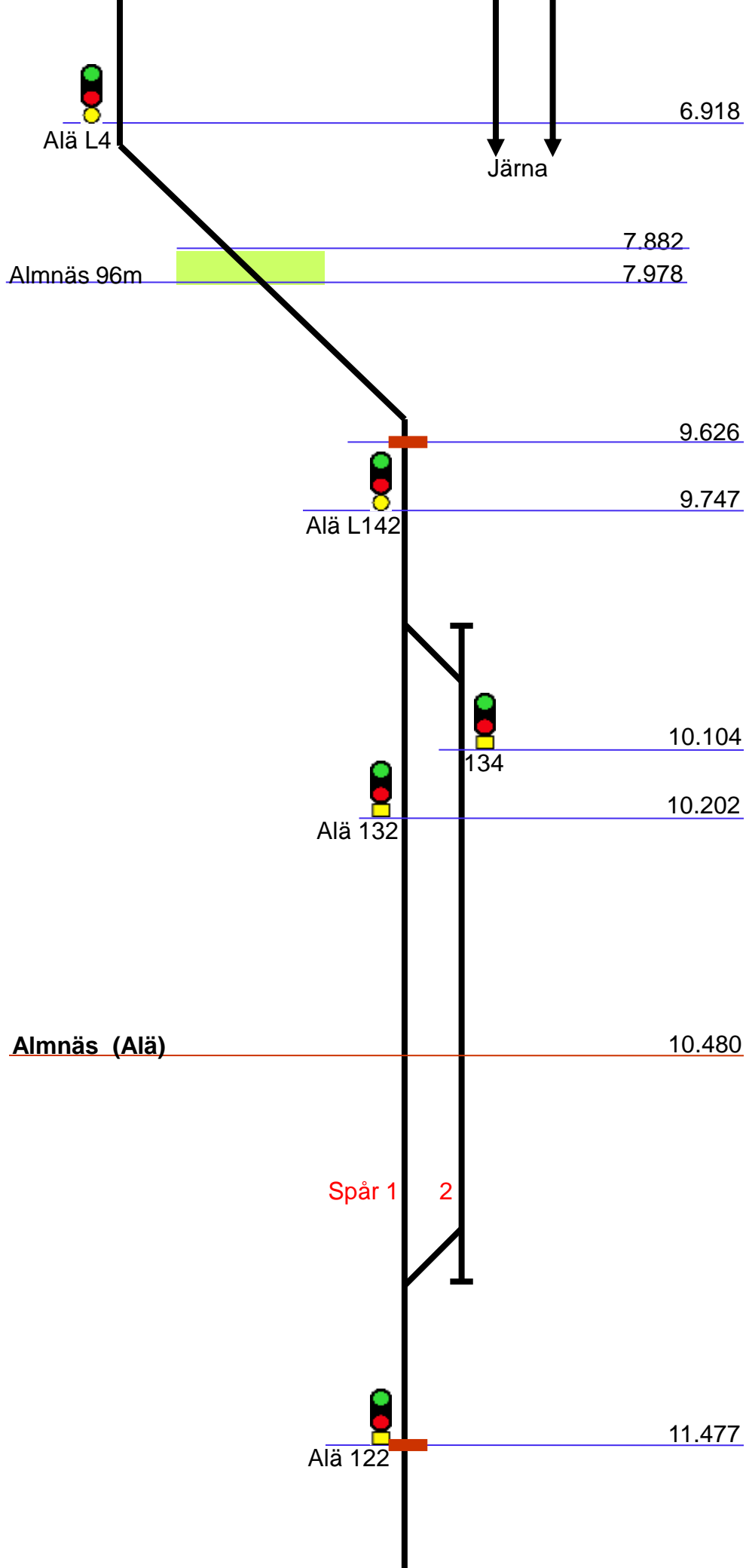

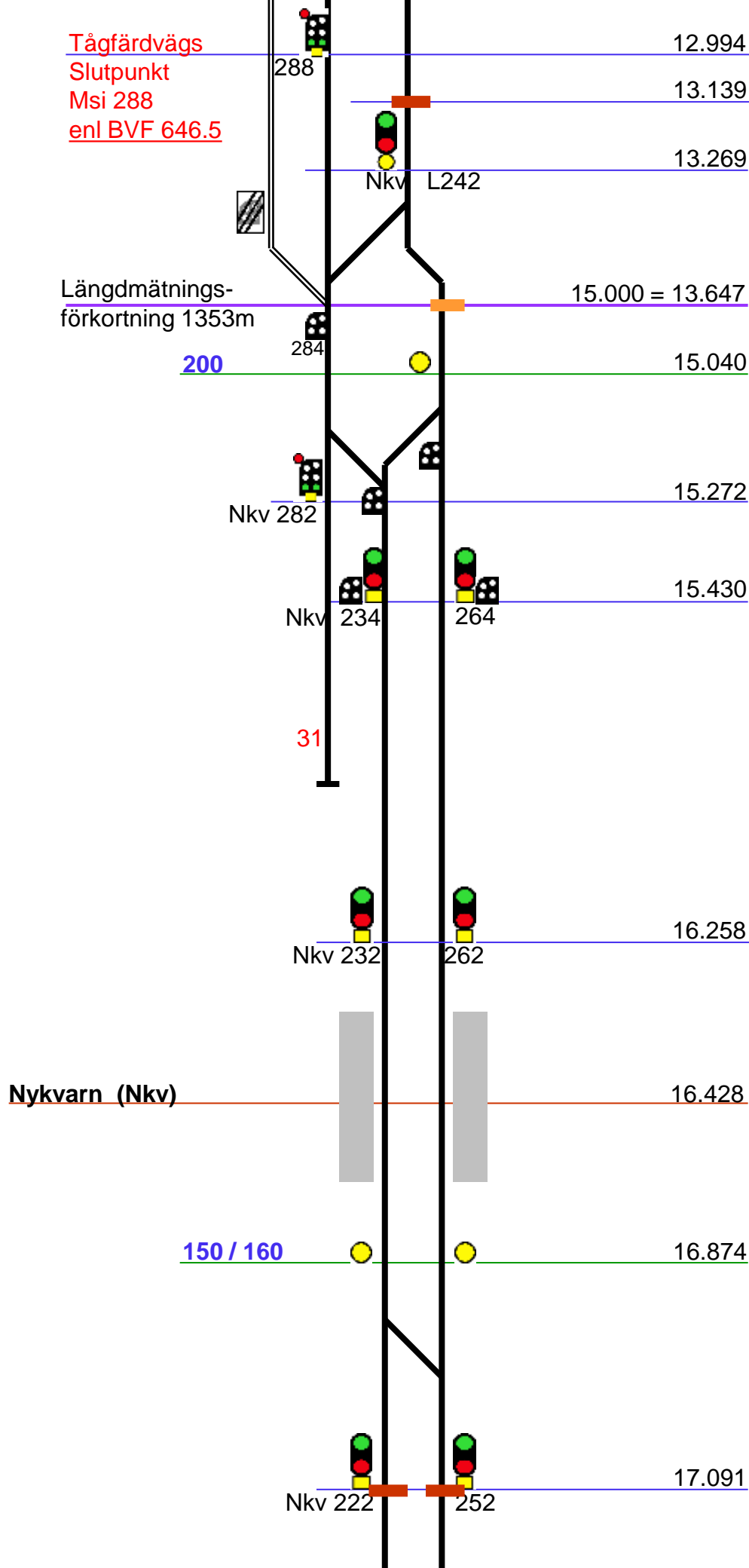

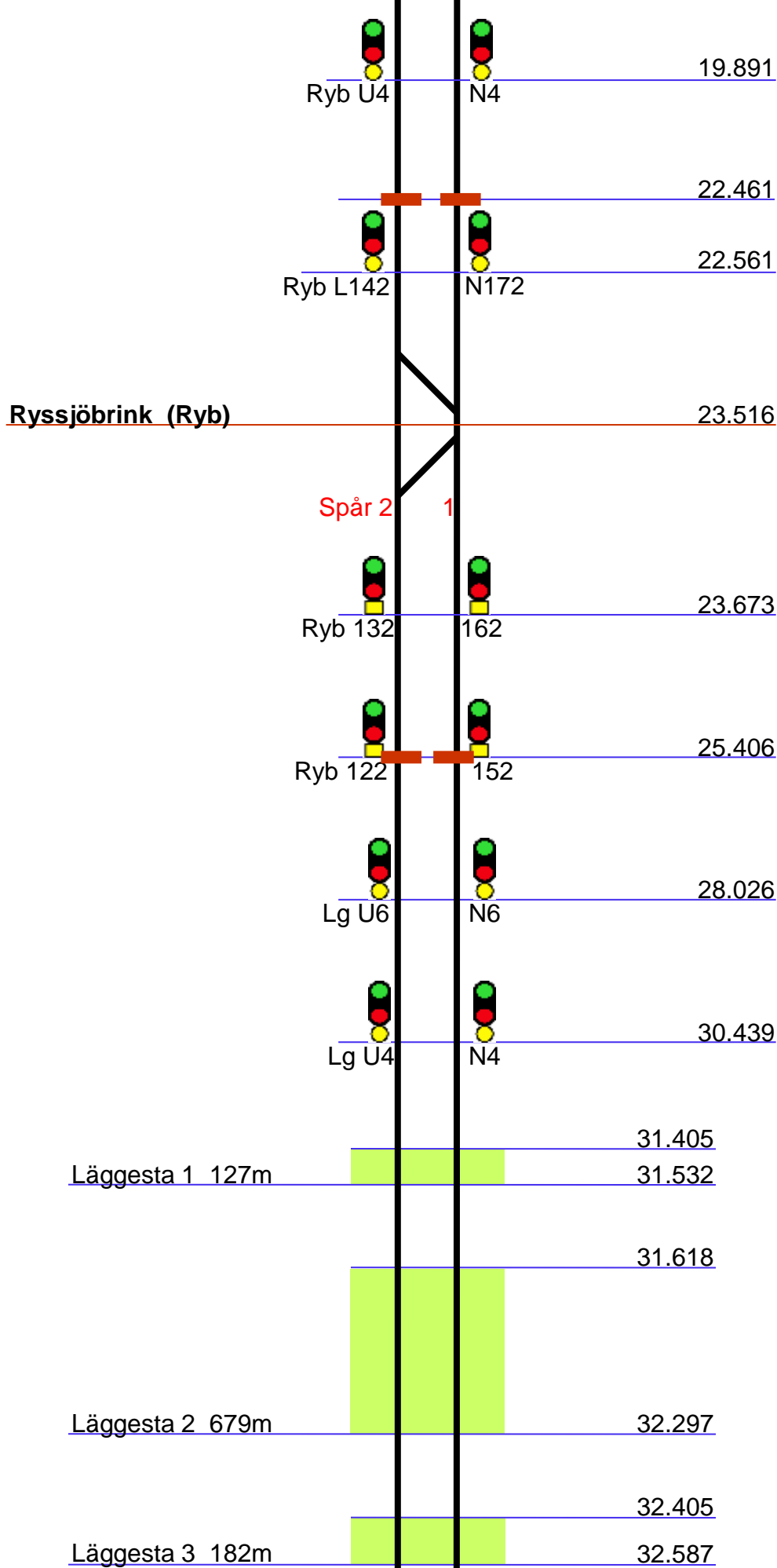

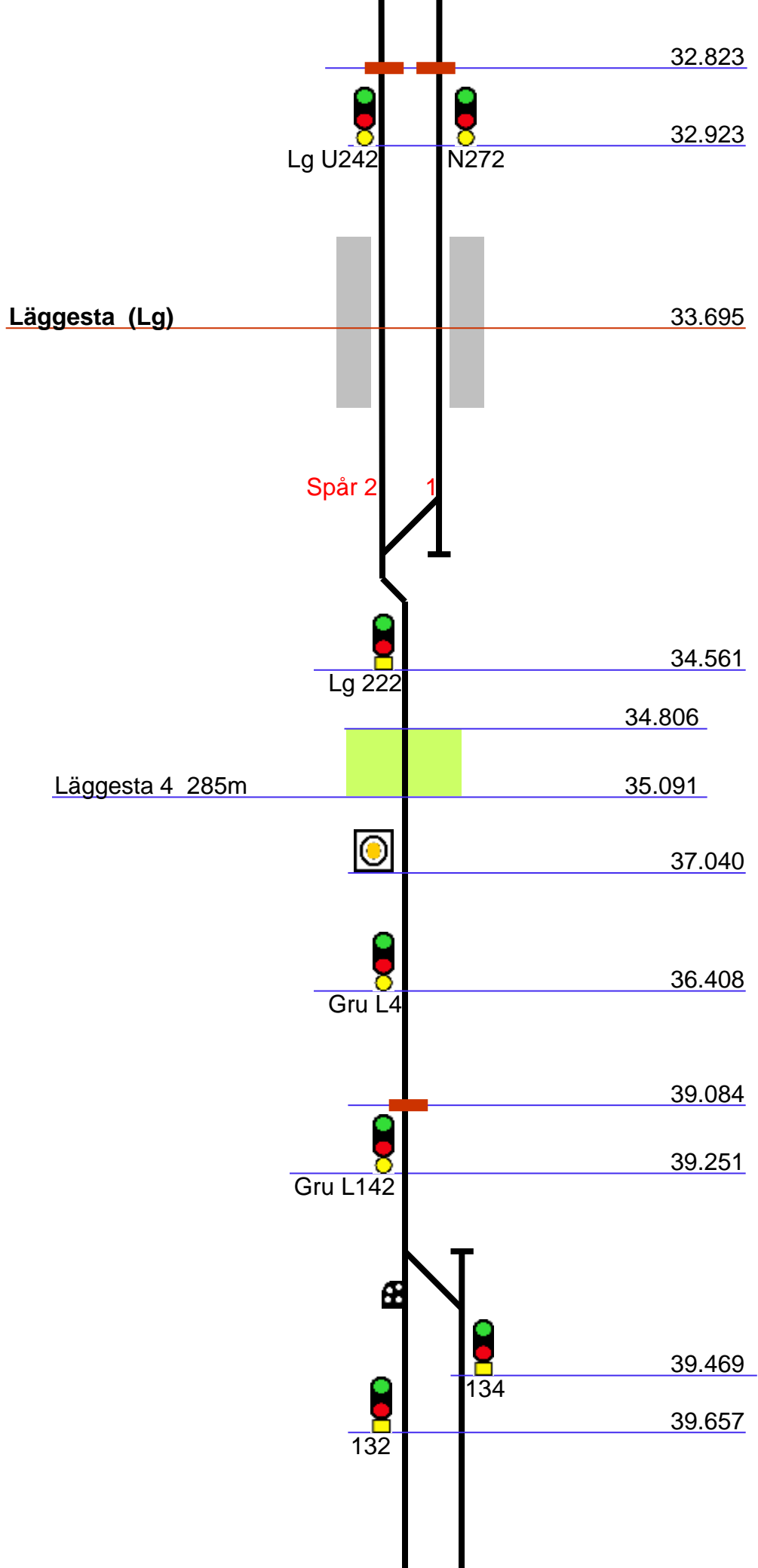

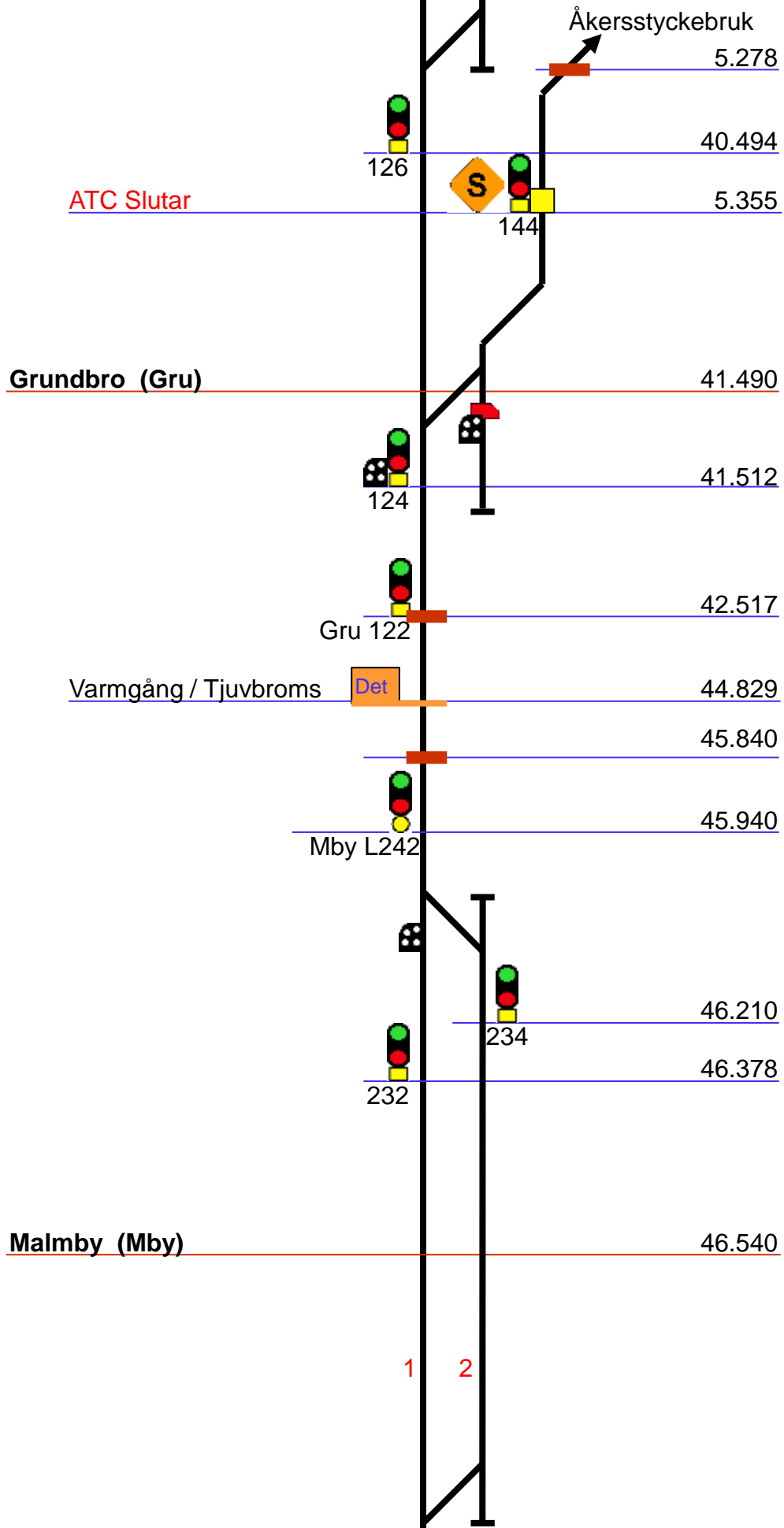

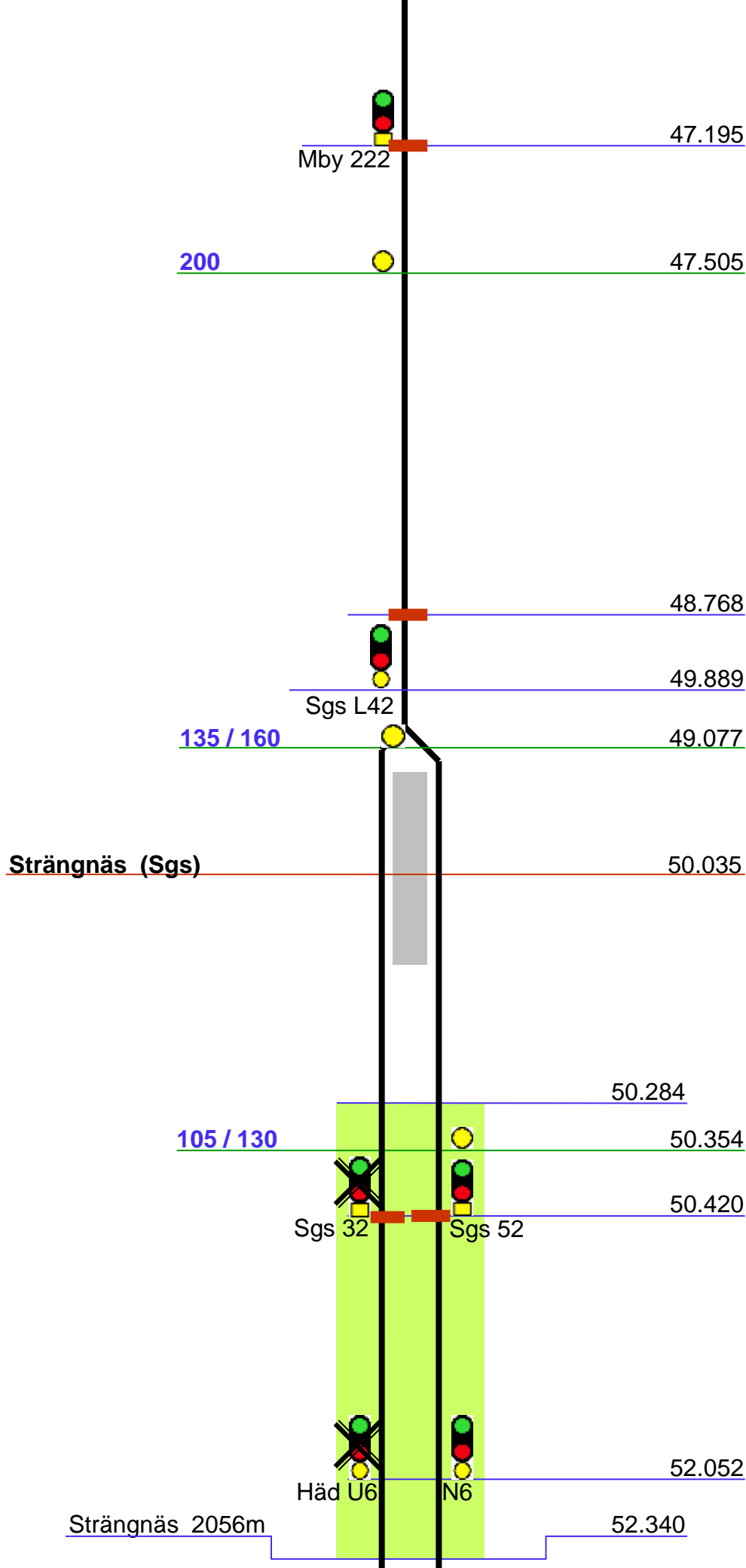

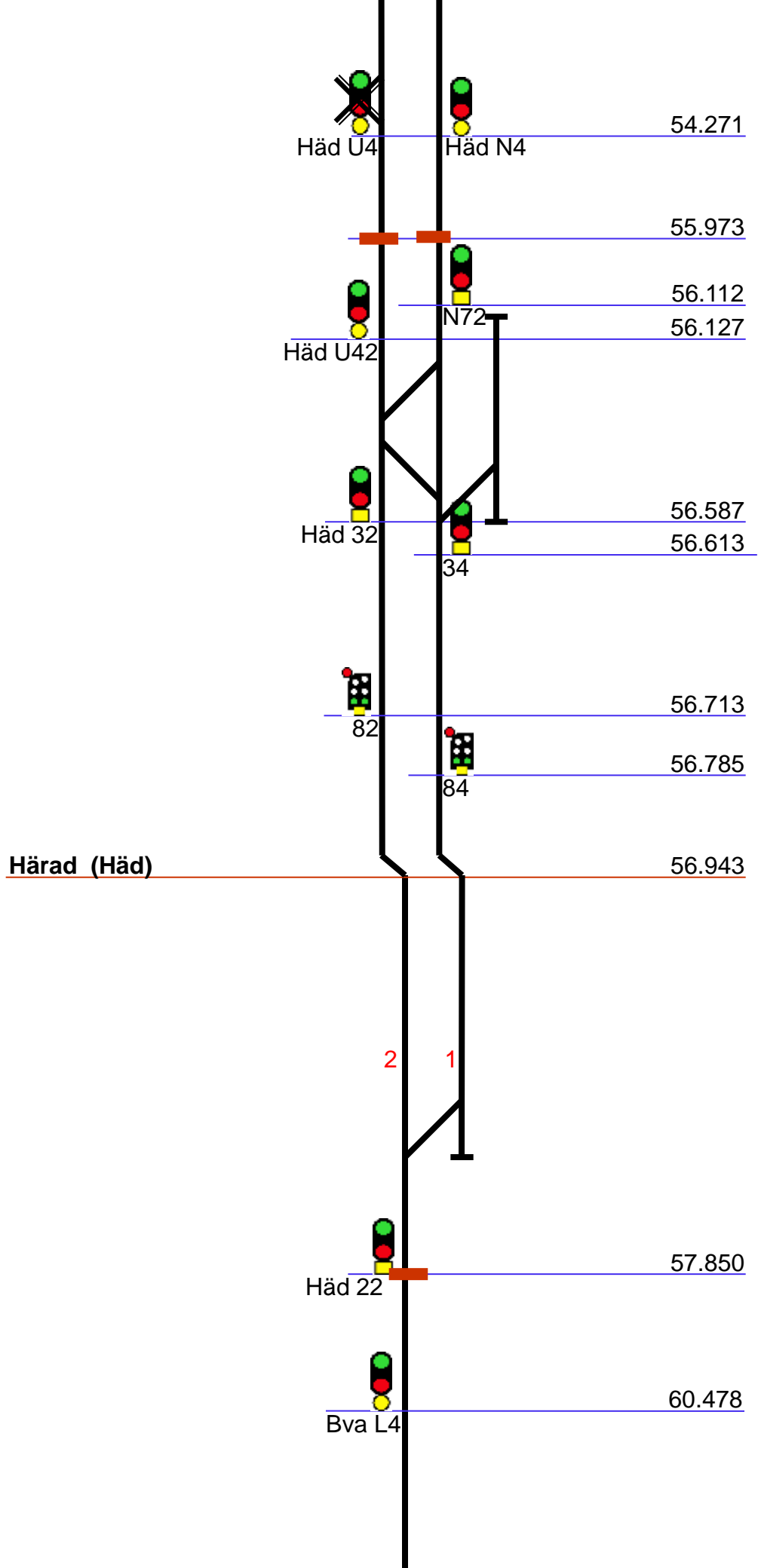

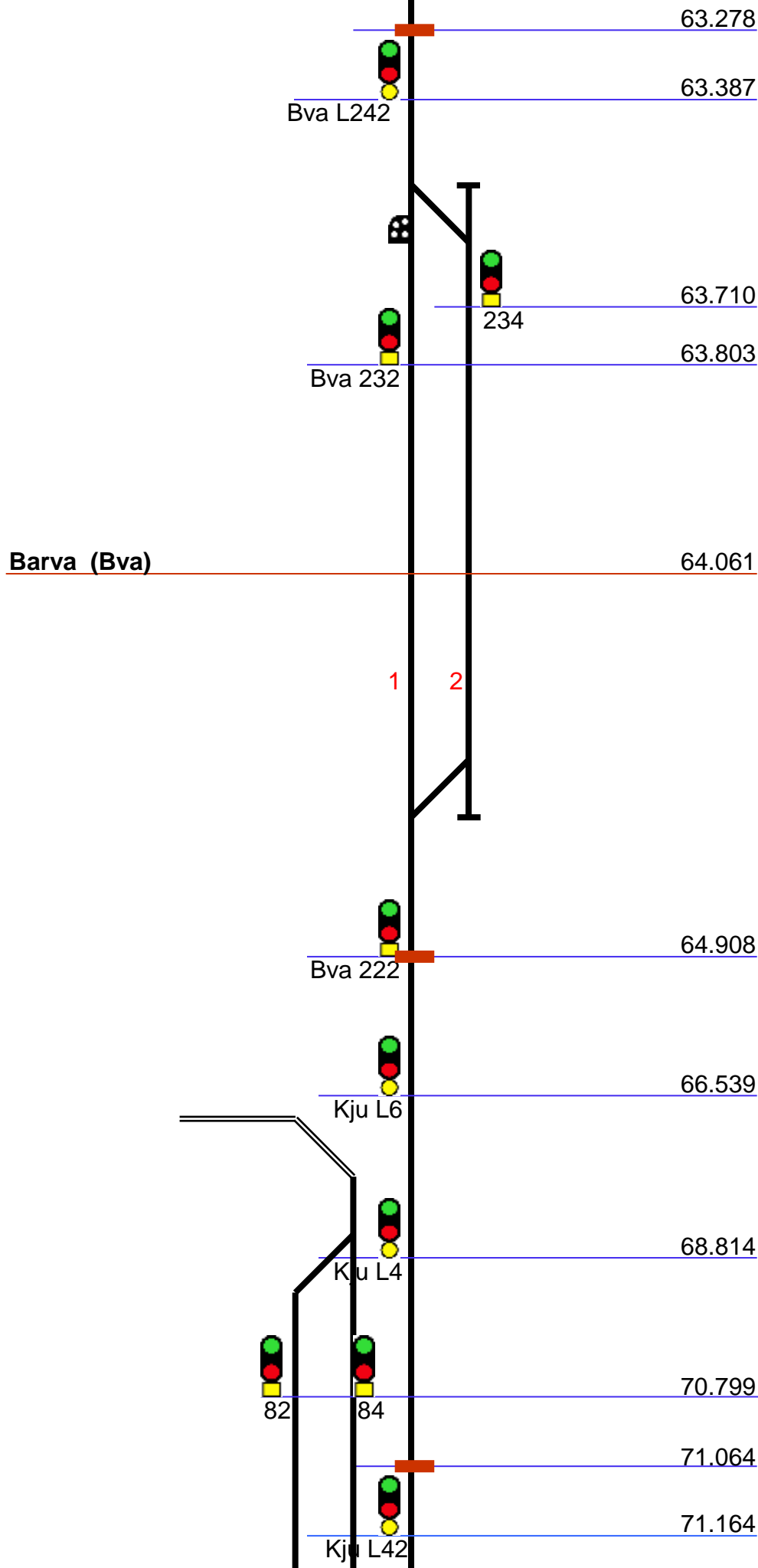

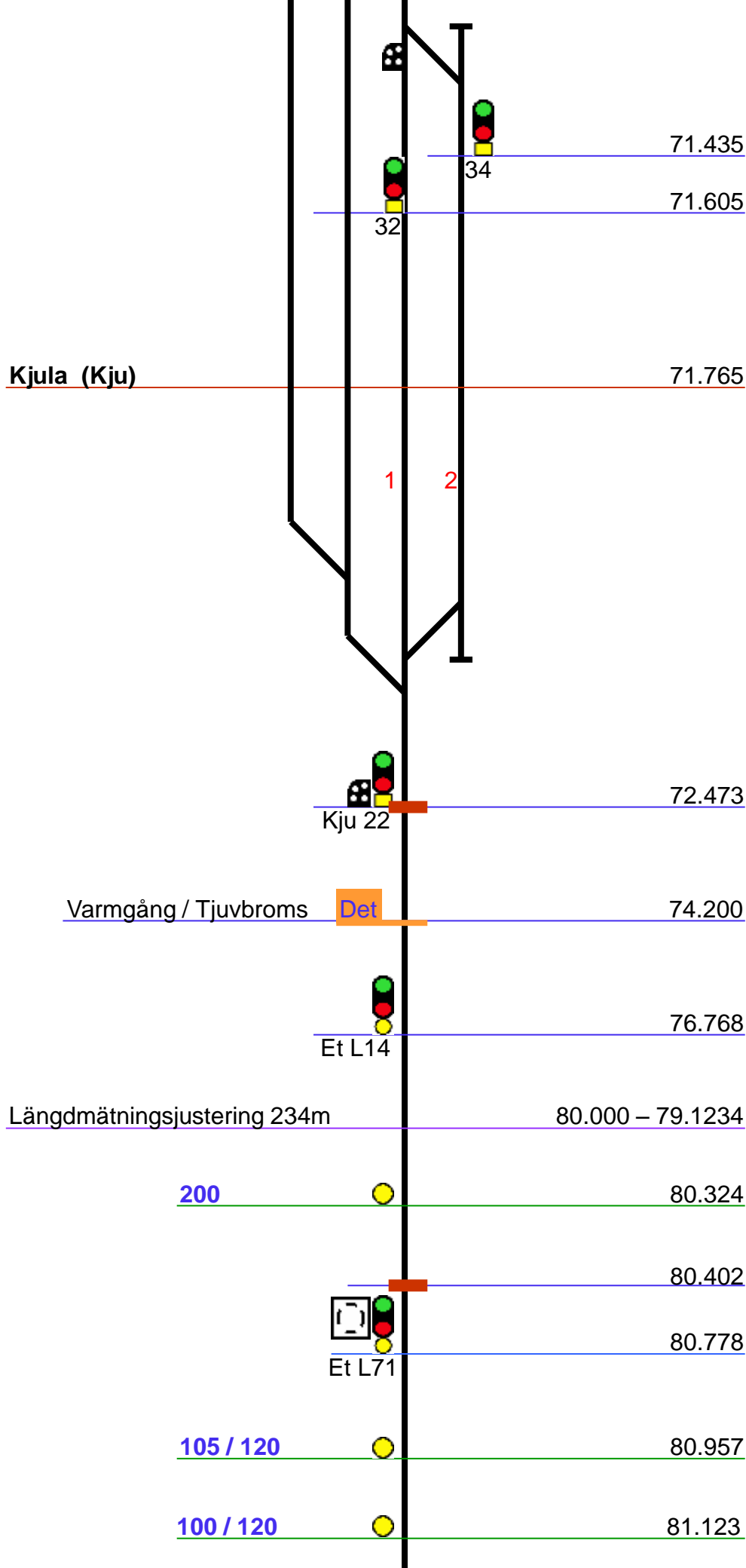

Eskilstuna

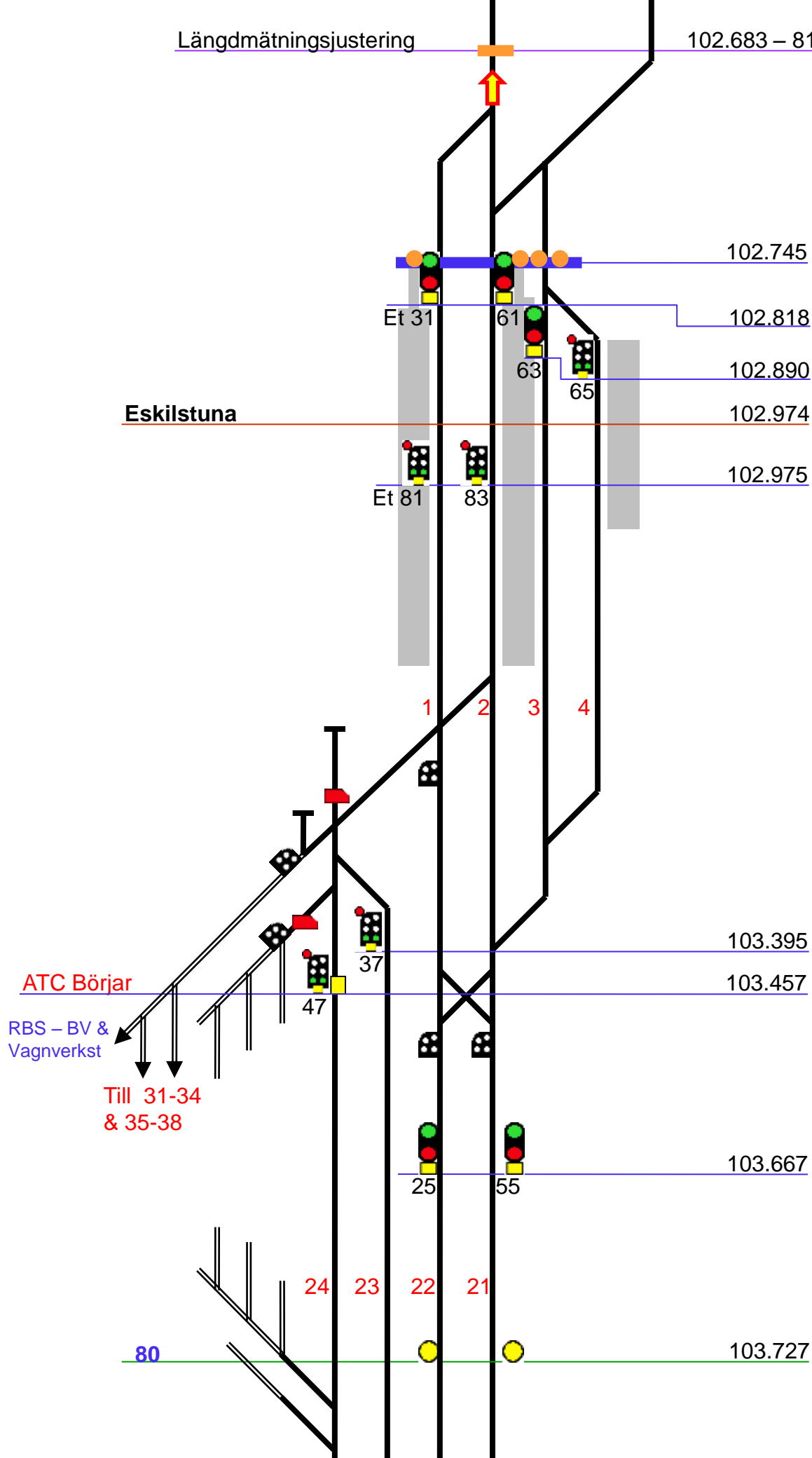

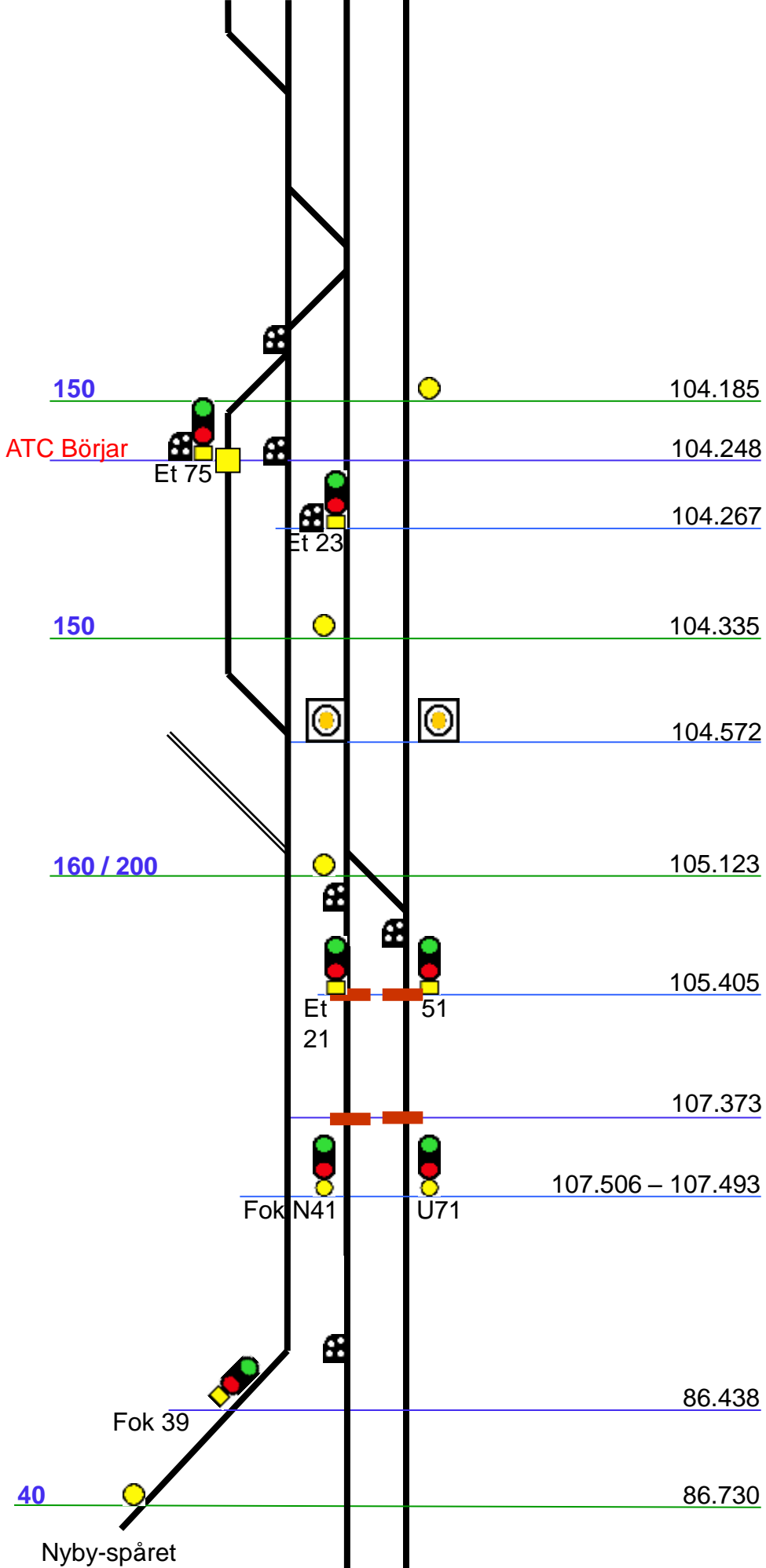

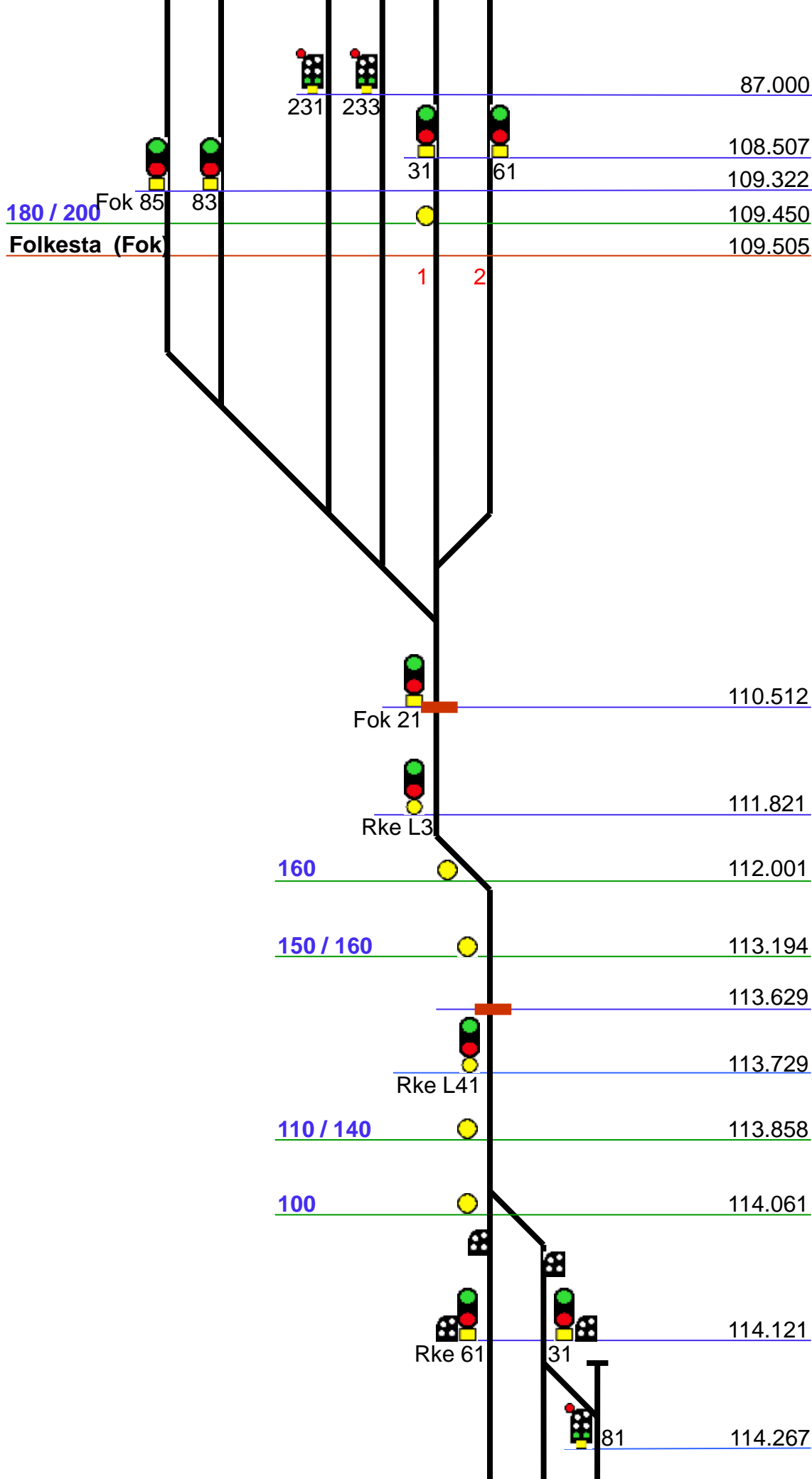

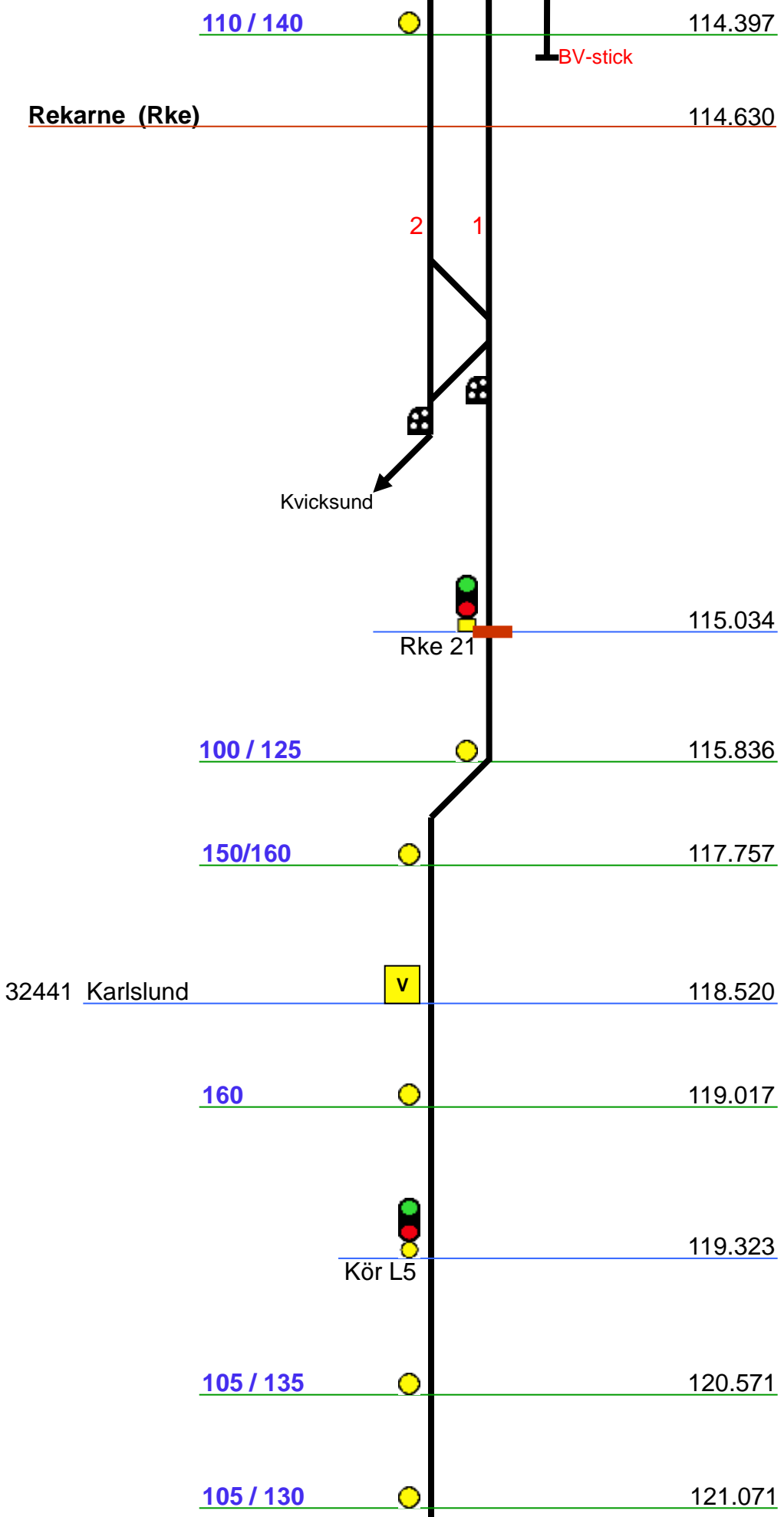

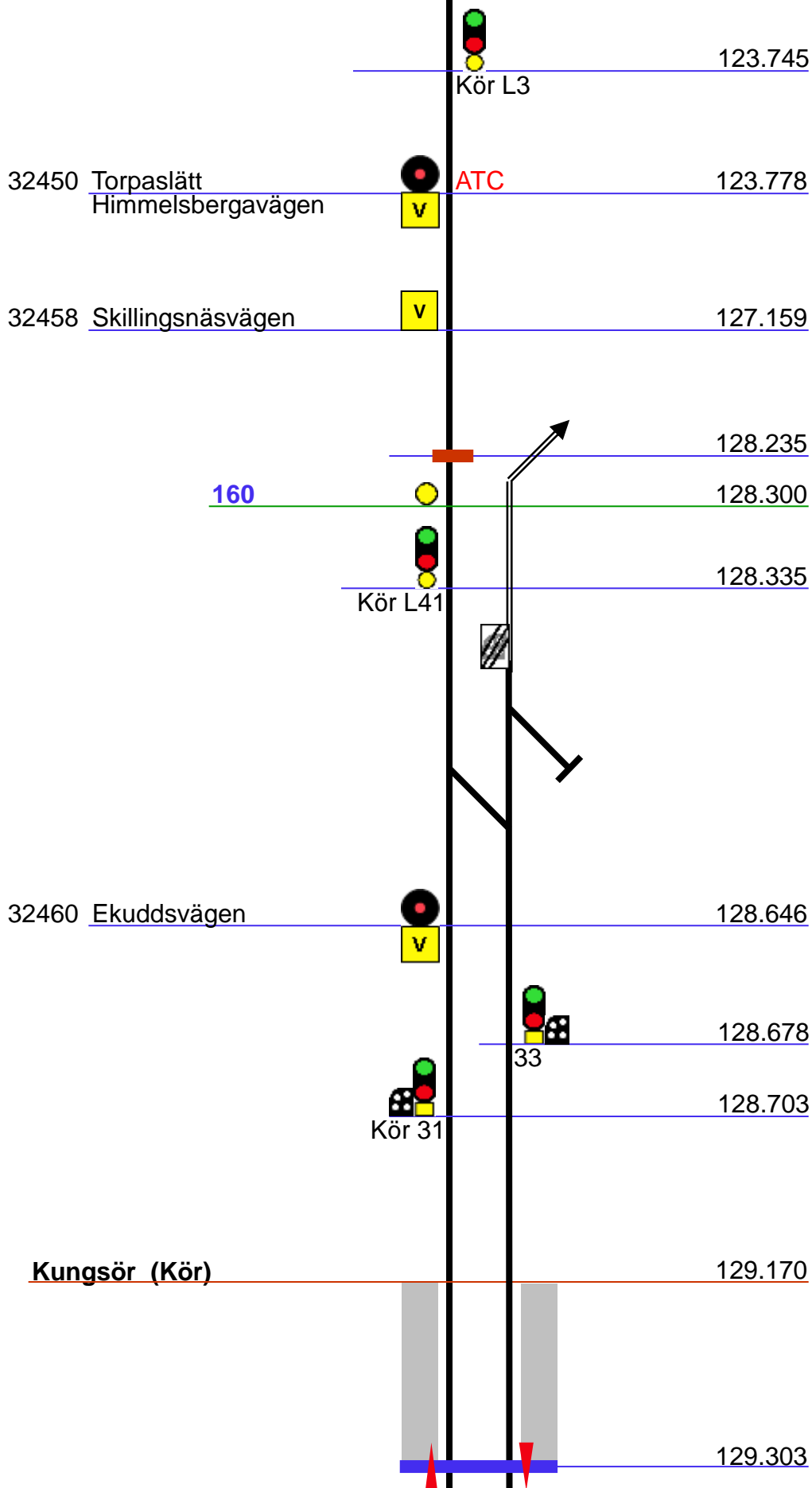

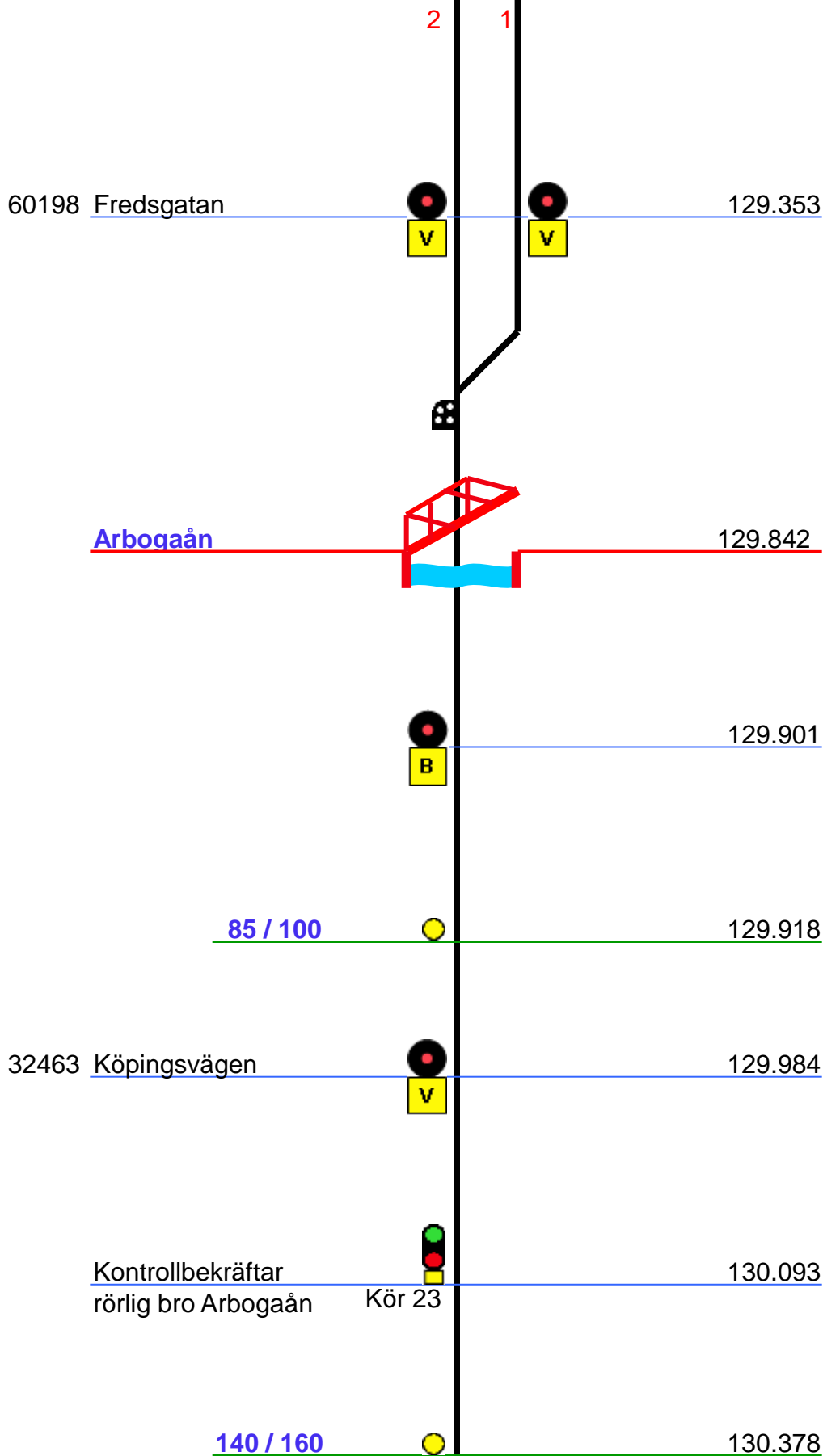

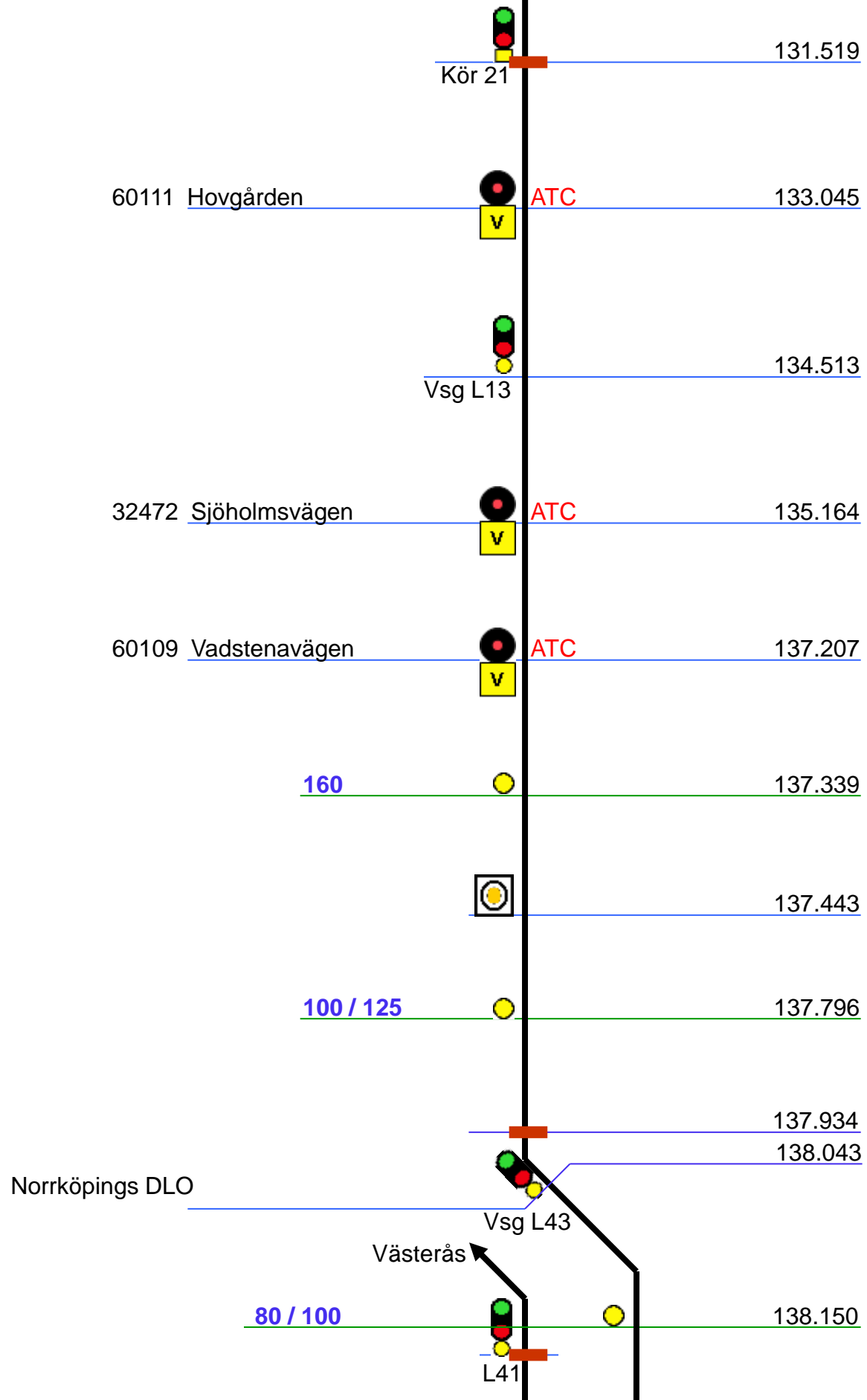

Längdmättnings-
förändring mot Kör
Valskog (Vsg)

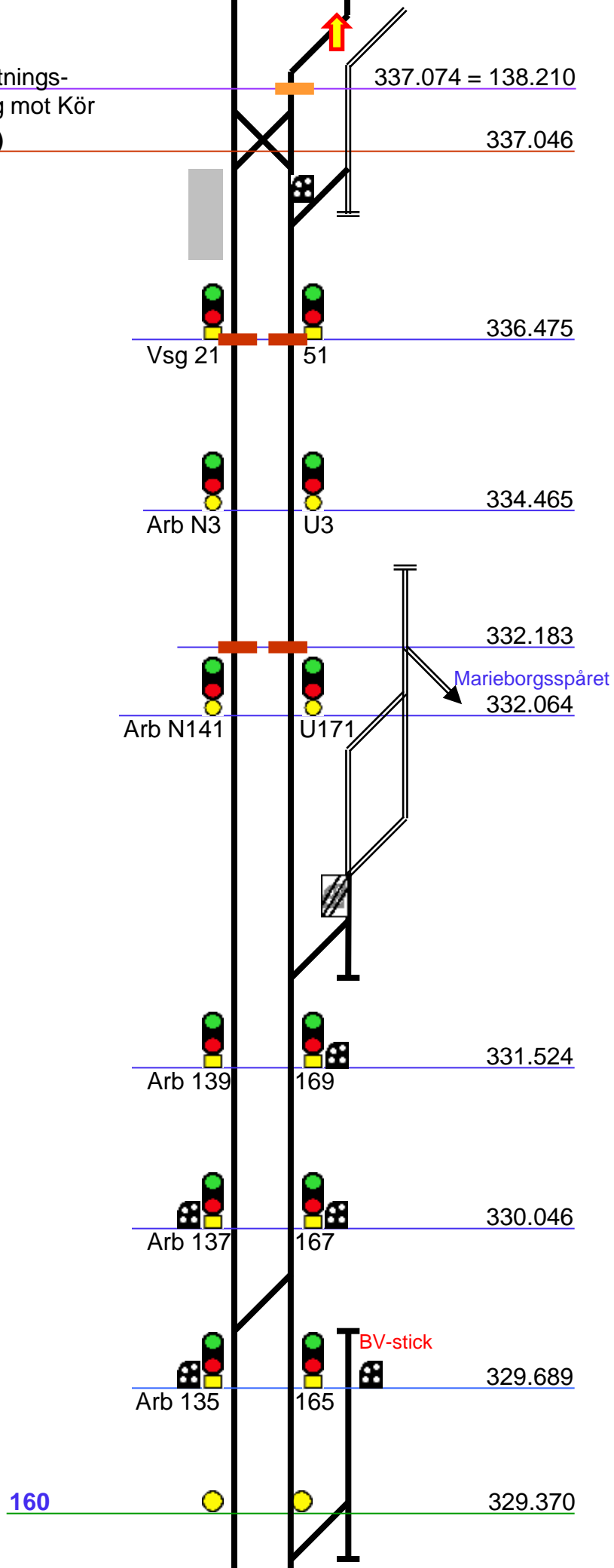

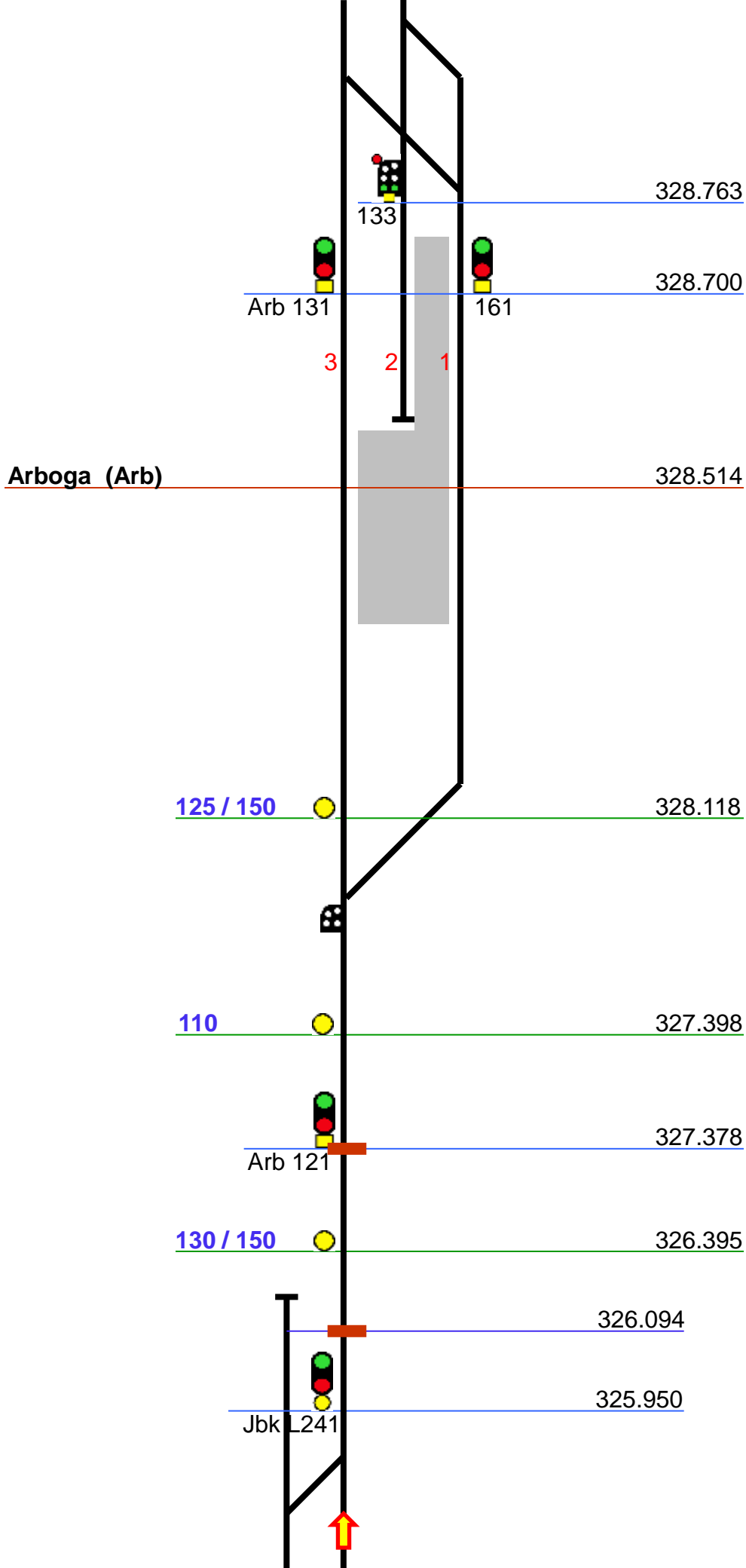

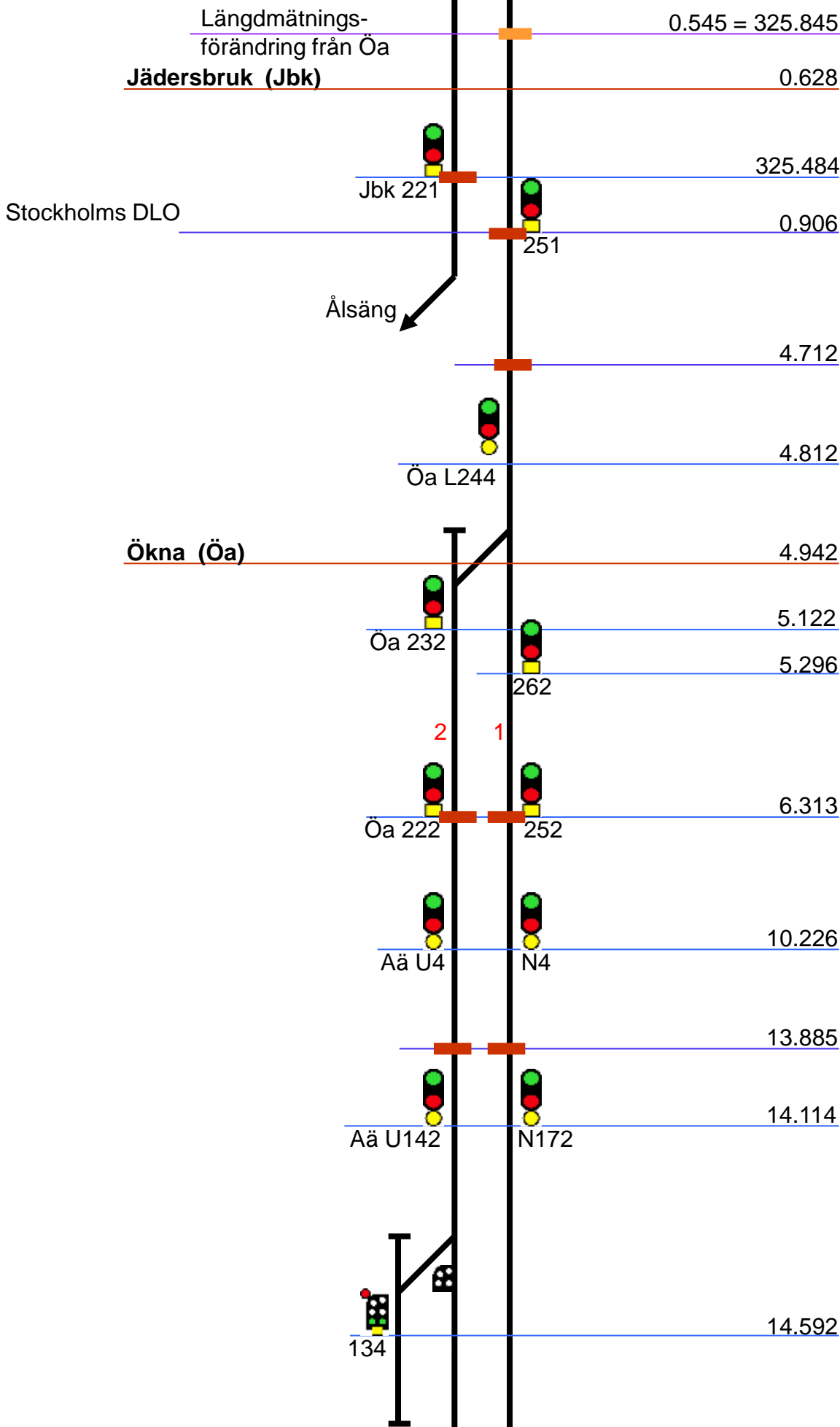

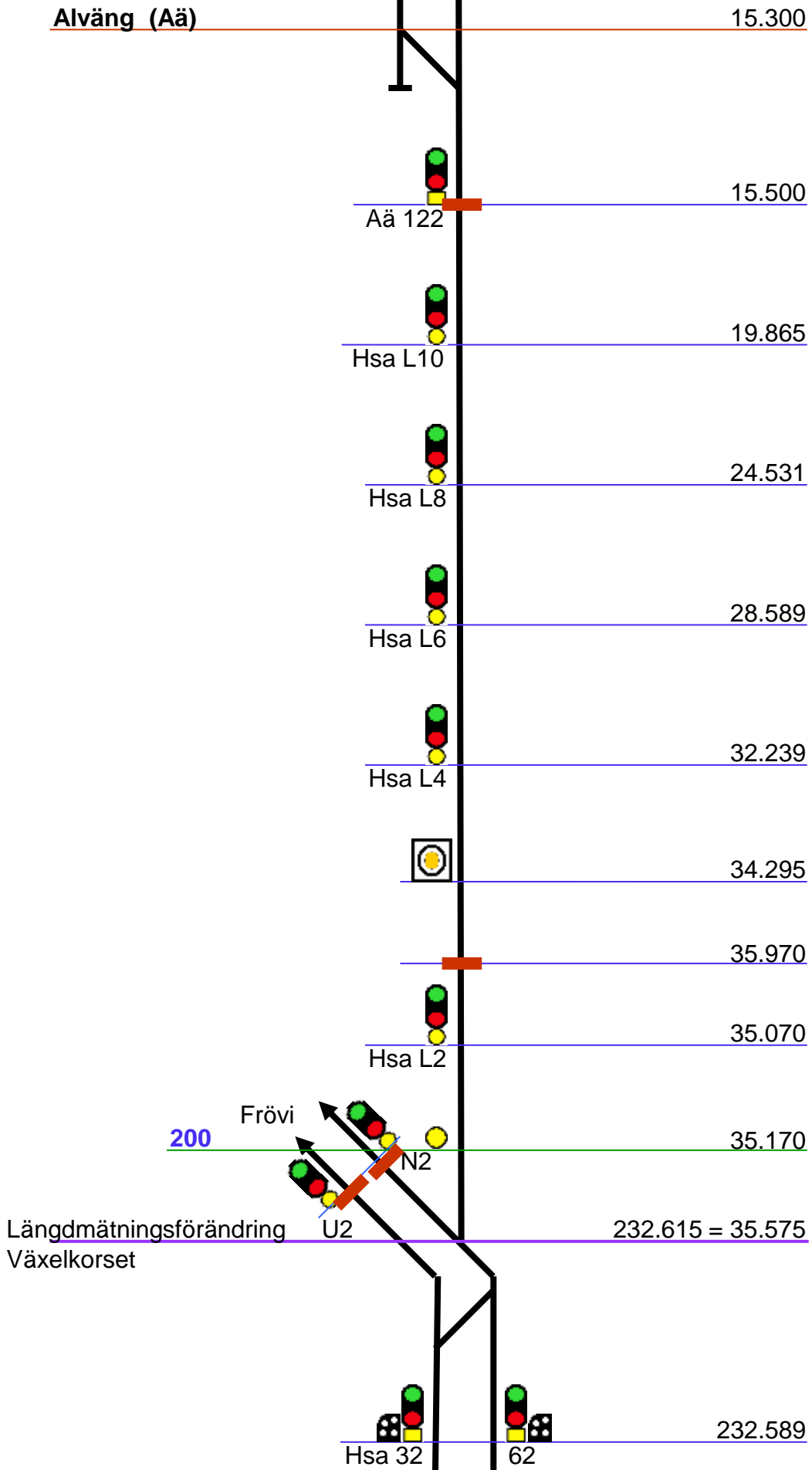

24643 Kårstavägen

232.086

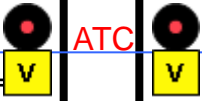

Hovsta (Hsa)

231.912

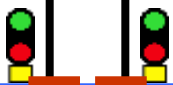
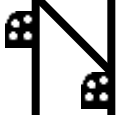
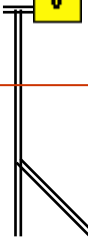

231.383

Hsa 22 52

24642 Yxstaby

230.386

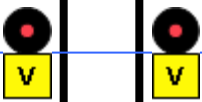

229.766

Ör U6 N6



228.206

Ör U4 N4



226.677



226.587

Ör U2 N2

130 / 140



226.184

24638 Hagabyvägen

225.988

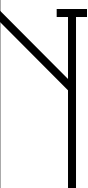
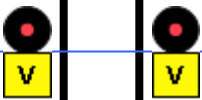

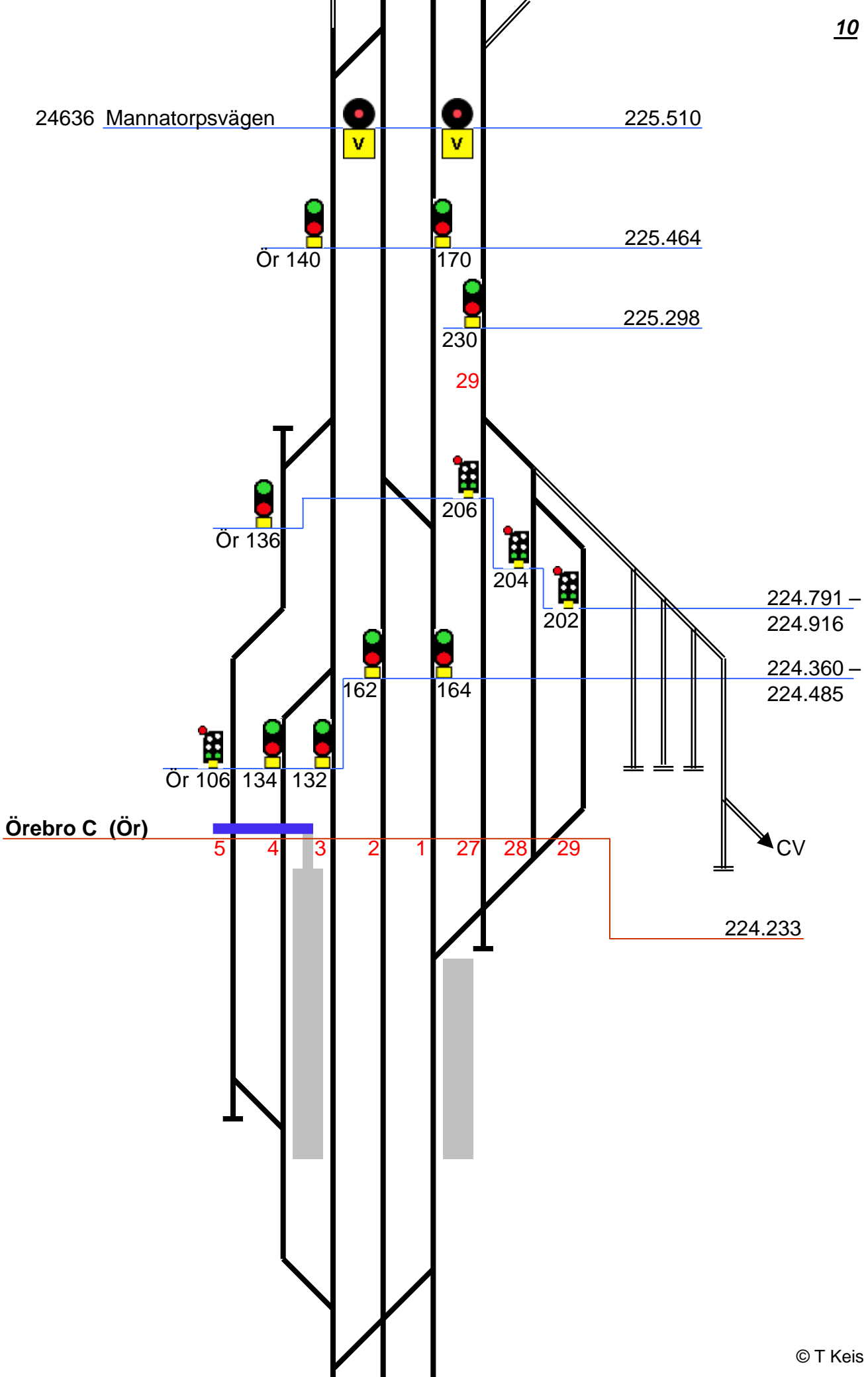

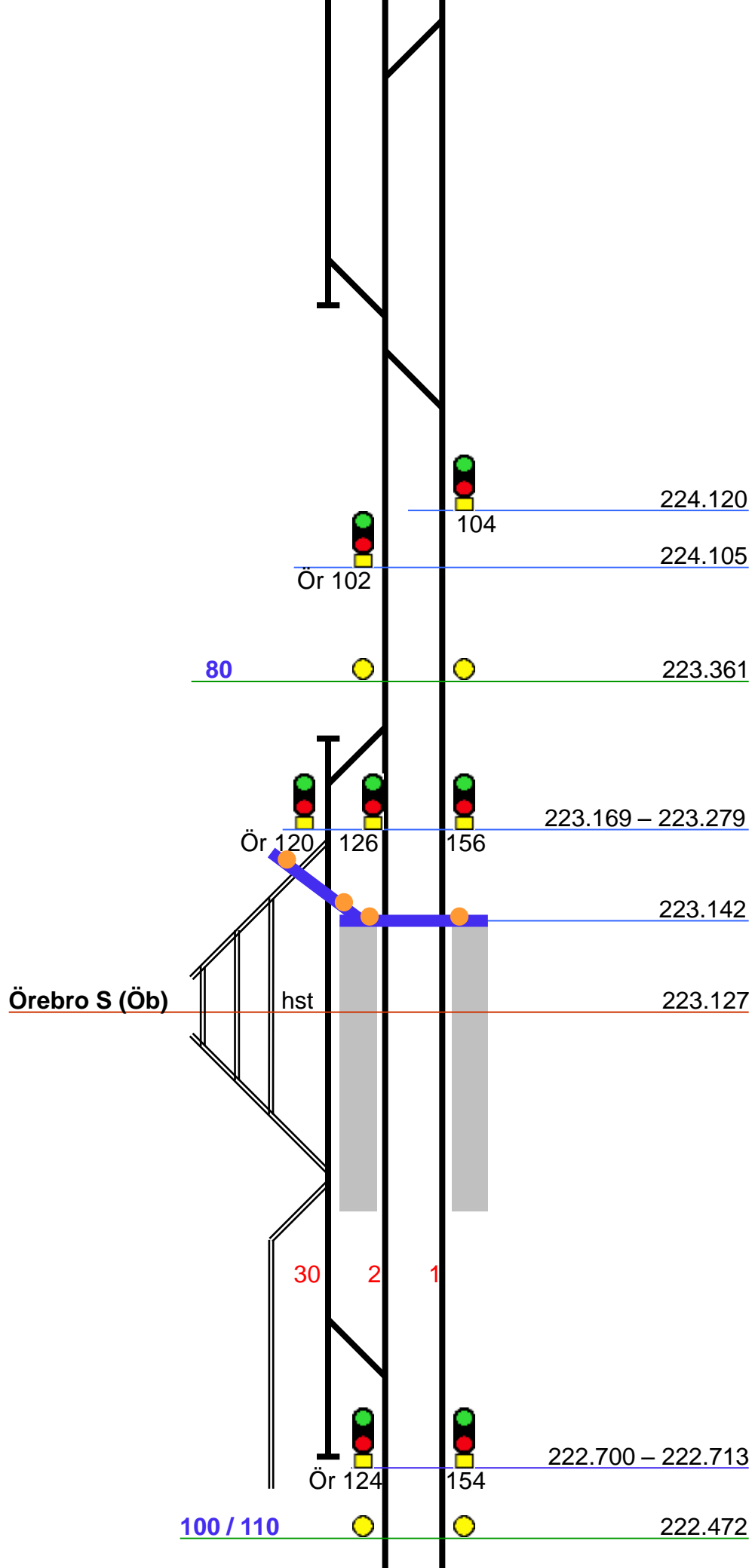

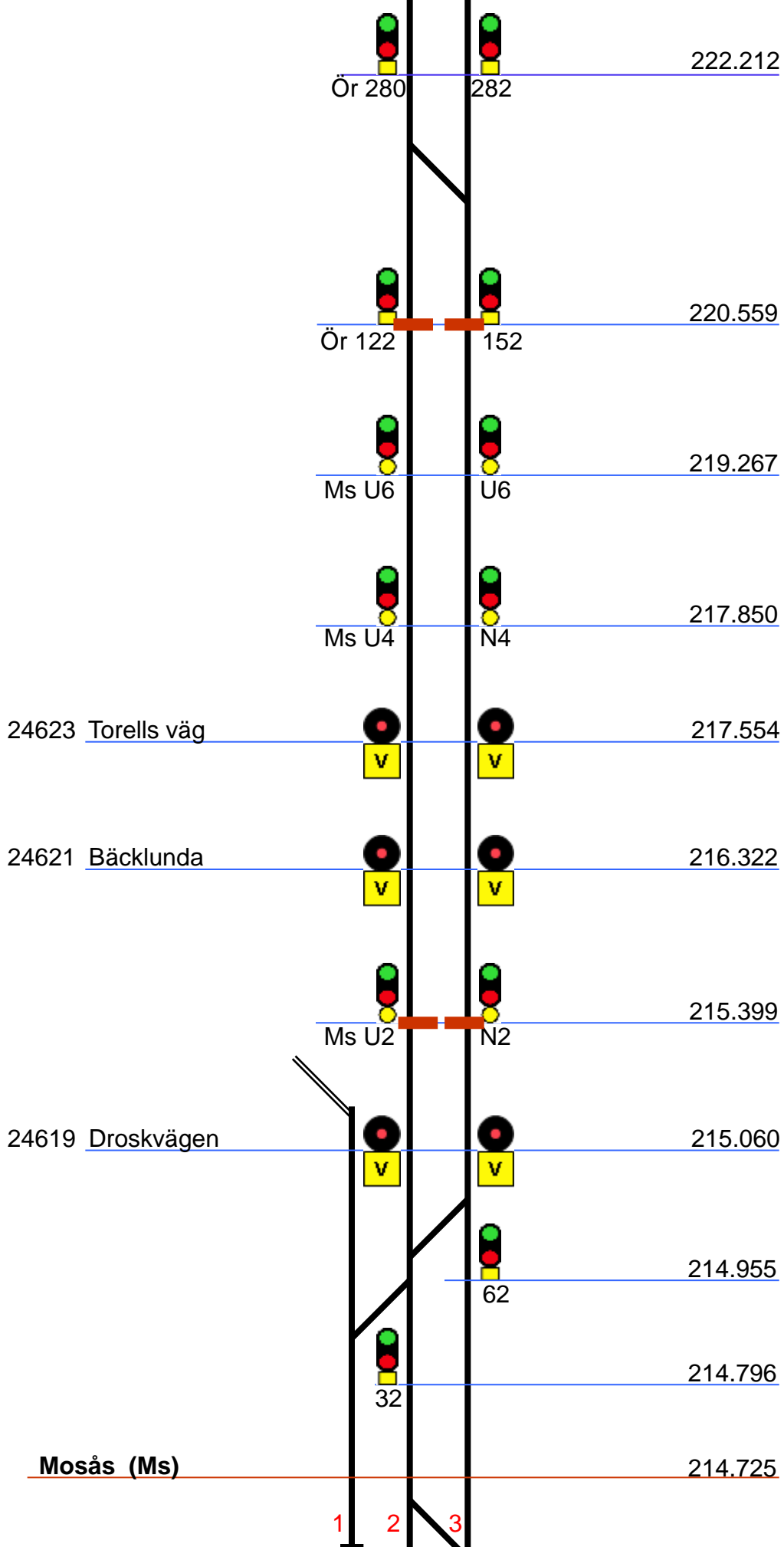

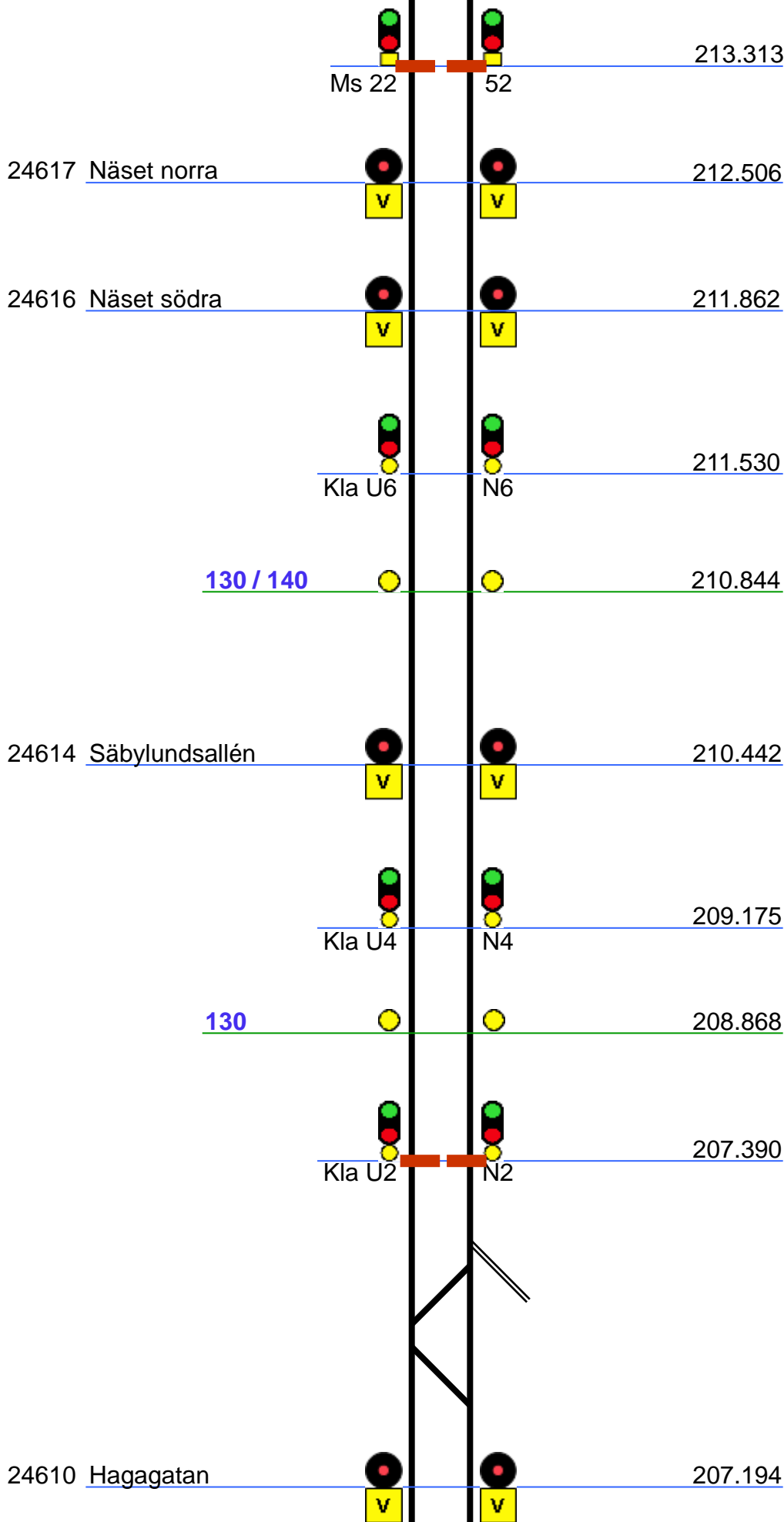

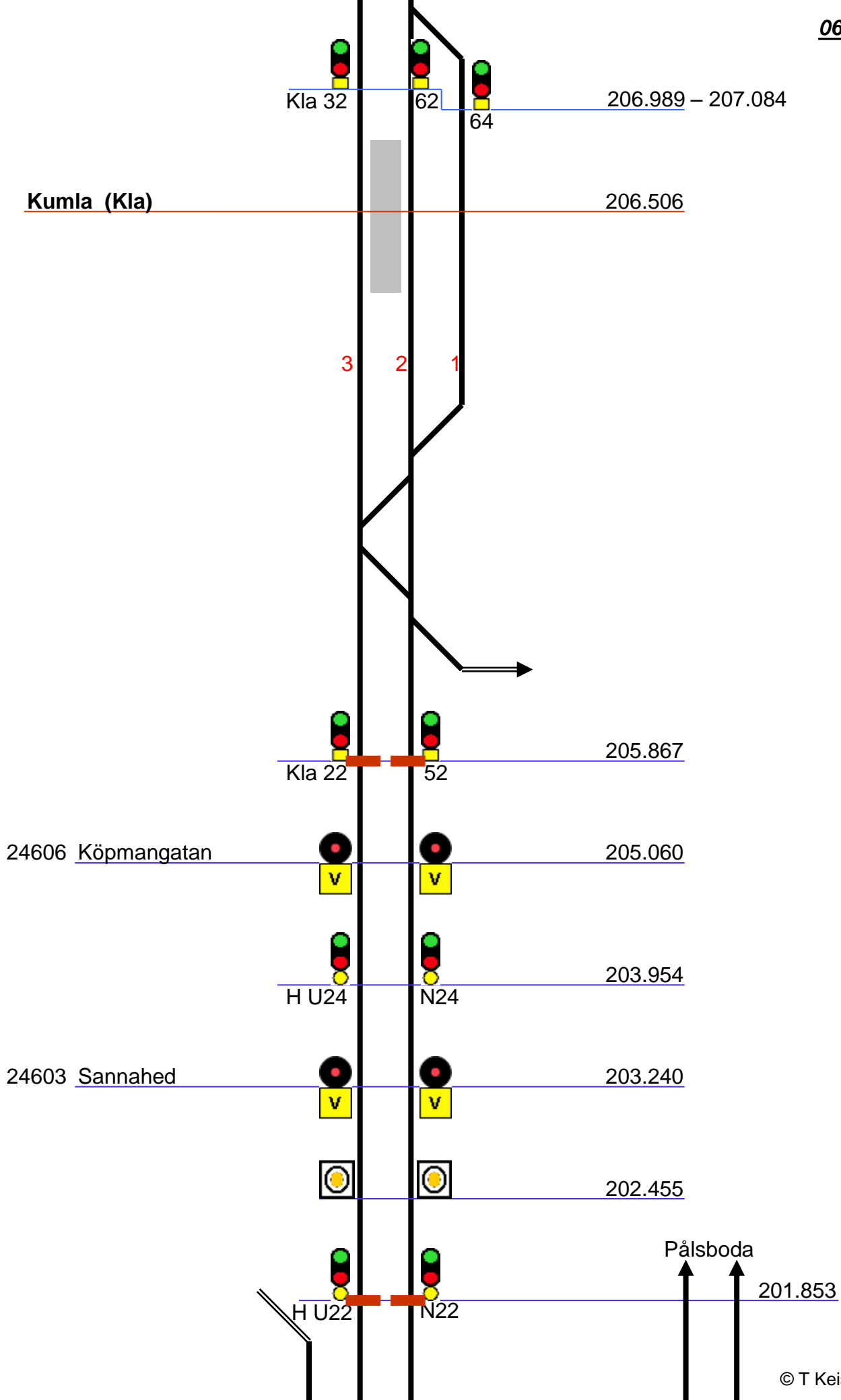

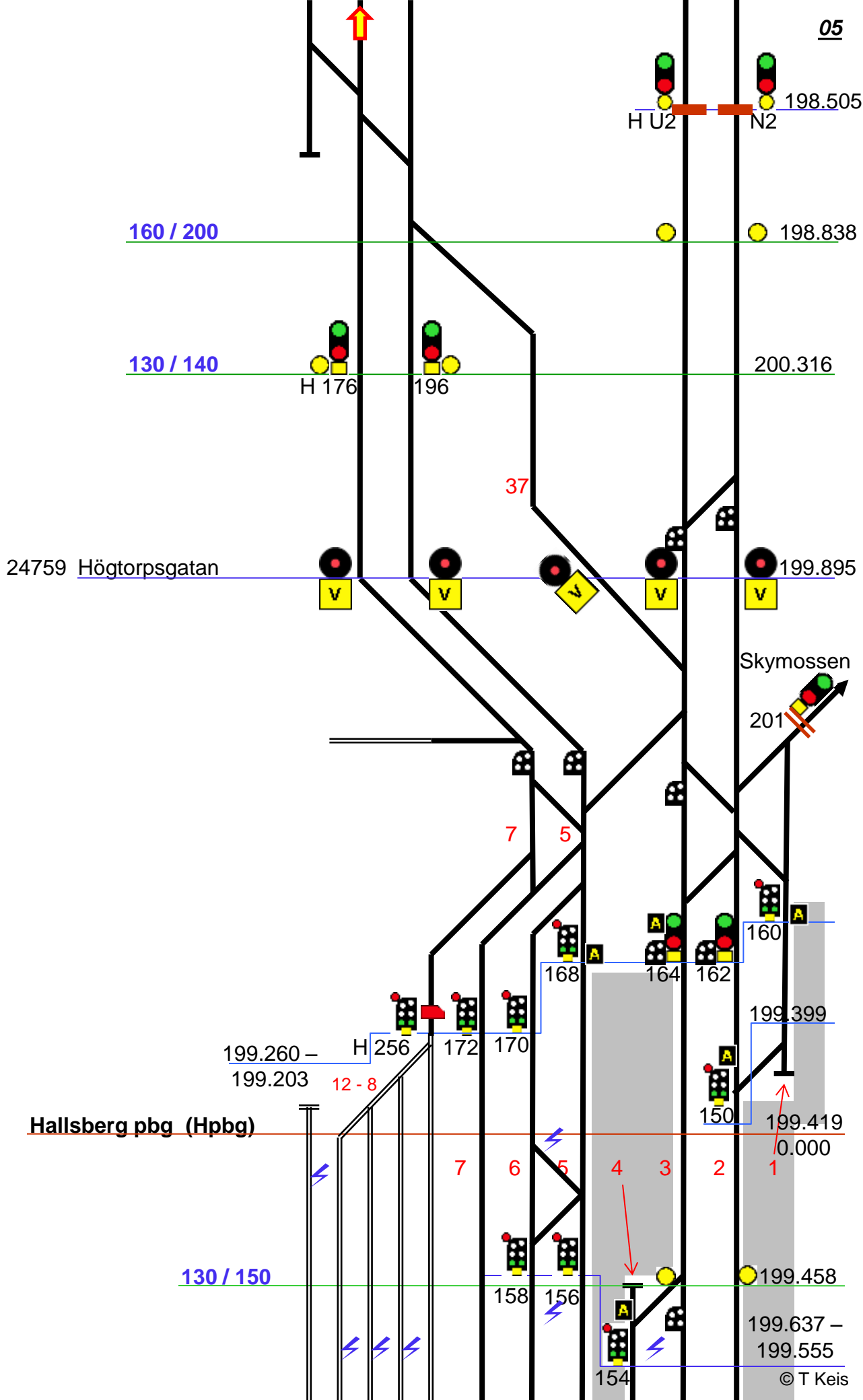

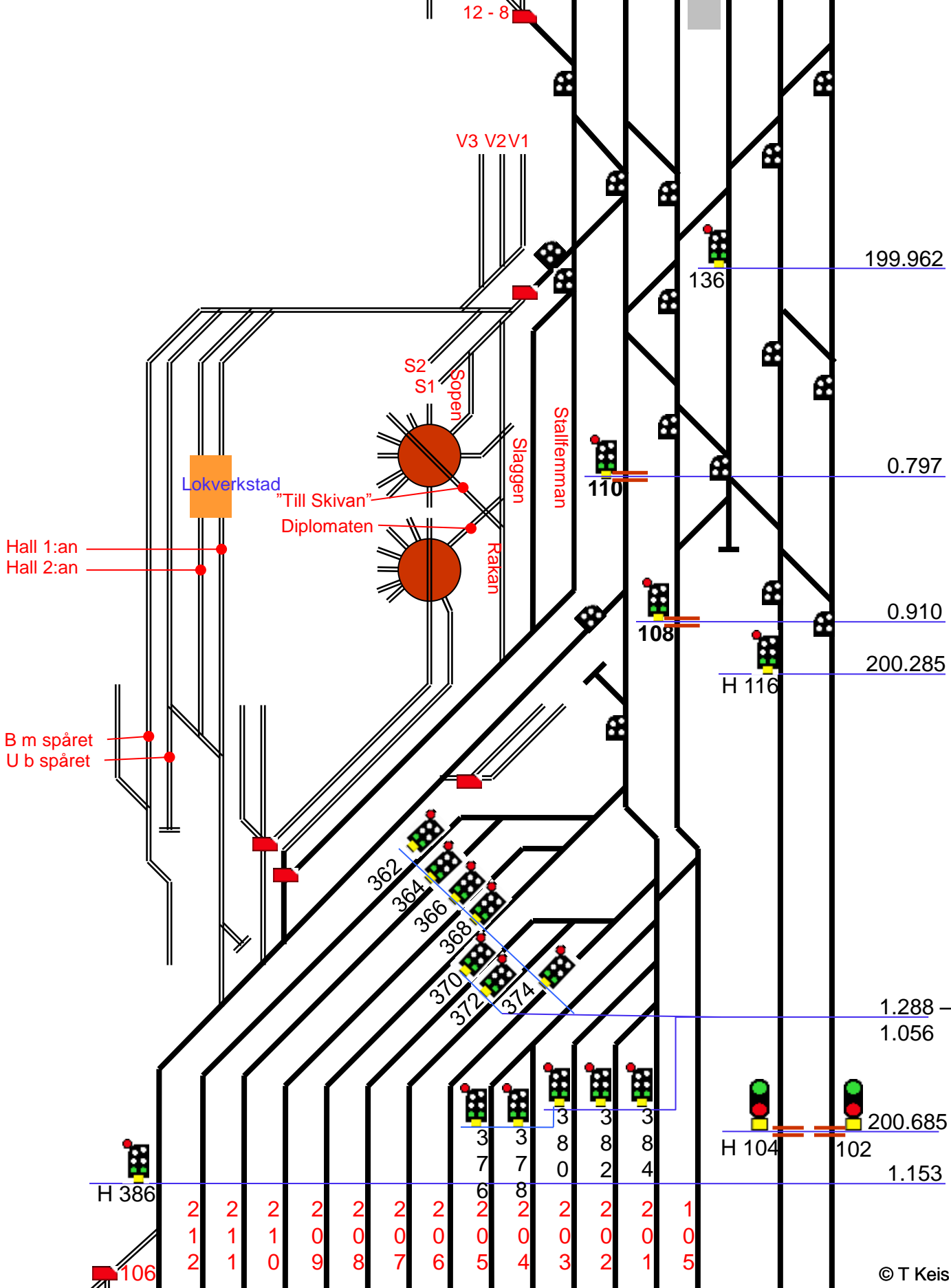

Hall 1:an
Hall 2:an

B m spåret
U b spåret

12 - 8

V3 V2V1

199.962

136

0.797

110

0.910

108

200.285

H 116

1.288 -

1.056

200.685

H 104

102

1.153

H 386

106

2	2	2	2	2	2	2	2	2	2	2	2	1
1	1	1	0	0	0	0	0	0	0	0	0	0
2	1	0	9	8	7	6	5	4	3	2	1	5

U - Gruppen

2	2	2	2	2	2	2	2	2	2	2	2
1	1	1	0	0	0	0	0	0	0	0	0
2	1	0	9	8	7	6	5	4	3	2	1

1
0
6

1
0
5

1.668

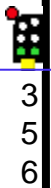

201.520

35-21

18-11

48-36

59-56



604



602

202.242

346

60

2.282

308

2.316

R-Gruppen

150 / 200

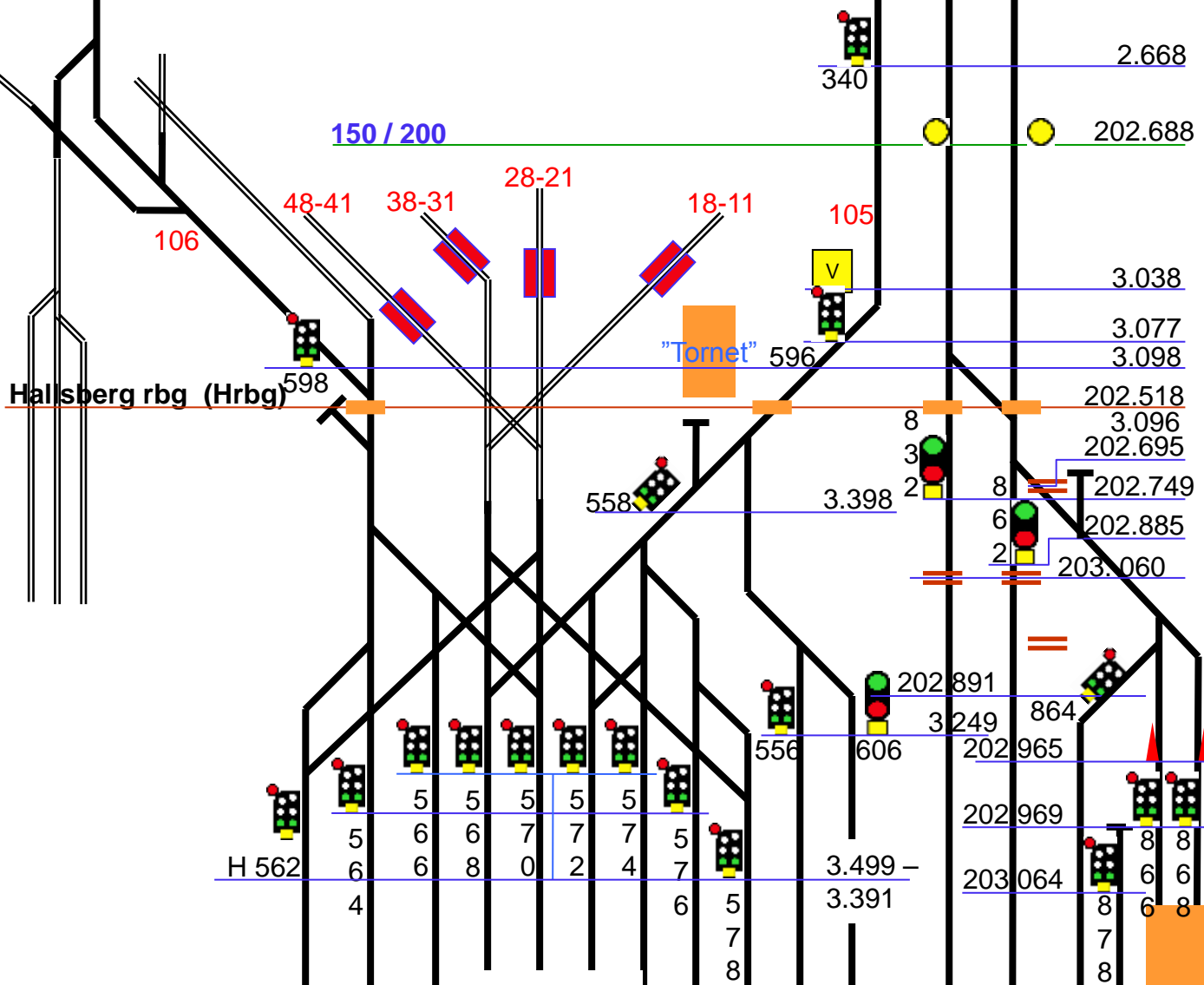

I-Gruppen

Hallsberg Posten (Hpn)

106

3	3	3	3	3	3	3	3	1
0	0	0	0	0	0	0	0	0
8	7	6	5	4	3	2	1	5

20

70

80

3970

